



Proposed Residential Development

Former BAE Factory,
Ravensworth Road,
Birtley, Gateshead

Transport Assessment &
Travel Plan prepared on
behalf of Gleeson
Regeneration Ltd

August 2023

Proposed Residential Development, Former BAE Factory, Ravensworth Road, Birtley, Gateshead

Project No: MTP Ref: 22-024-N
Document Reference No: 22-024-N
Document Title: Transport Assessment & Travel Plan
Date: August 2023
Client Name: Gleeson Regeneration Ltd
Project Manager: Darran Kitchener
Author: Amy Wreford

Produced By: **Milestone Transport Planning Limited**
Abbey House, 282 Farnborough Road, Farnborough, Hants GU14 7NA - Tel: 01483 397888
Gateshead IBC, Mulgrave Terrace, Gateshead, Tyne & Wear, NE8 1AN - Tel: 0191 3387220
Email: mail@milestonetp.co.uk
Web: www.milestonetp.co.uk

Document history and status

Revision	Date	Description	Prepared By	Checked By	Authorised By
-	13/12/21	Draft for comment	A. Wreford	D. Kitchener	D. Kitchener
-	23/12/21	Issued for planning following Client comments	A. Wreford	D. Kitchener	D. Kitchener
A	24/08/23	Revision to include junction impact assessments, response to council comments and revised layout	S. Boulton	A. Wreford	D. Kitchener

CONTENTS

1.	Introduction, Background & Scope	1
	Introduction	1
	Background.....	2
	Scope of Report.....	3
2.	Planning Policy Context.....	5
	National Planning Policy Framework (2021)	5
	Core Strategy & Urban Core Plan for Gateshead & Newcastle 2010-2030	6
	Gateshead Council Making Spaces for Growing Places.....	6
	Summary	7
3.	Baseline Conditions & Site Accessibility.....	8
	Site Context.....	8
	Local Highway Network.....	8
	Existing Traffic Flows	12
	Traffic Accident Review.....	14
4.	Proposed Development & Access Strategy	17
	Proposed Access Arrangements.....	18
	Parking Provision	19
	Pedestrian & Cycle Infrastructure	21
	Emergency, Servicing & Refuse Vehicle Access.....	21
5.	Accessibility by Sustainable Transport	22
	Proximity to Local Amenities	22
	Pedestrian & Cycle Accessibility.....	23
	Public Transport Connections	26
	Accessibility Summary.....	27
6.	Accessibility Audit Review.....	28
	Initial Accessibility Audit (2011)	28
	Updated Accessibility Audit (2022)	30
7.	Travel Plan.....	32

	Strategy Overview	32
	Aim	32
	Objectives.....	32
	Sustainable Transport Infrastructure	32
	Travel Plan Delivery Strategy.....	32
	Travel Plan Measures	35
8.	Trip Generation, Distribution and Assignment	36
	Traffic Generation	36
	Traffic Generation Review	38
	Traffic Distribution and Assignment.....	38
9.	Traffic Impact Assessment & Mitigation	42
	Impact Assessment.....	42
	Assessment Methodology.....	42
	Assessment Findings	45
	Review of Previous Mitigation Measures	51
	Additional Mitigation Measures.....	51
10.	Construction Phase.....	52
11.	Summary & Conclusions	53

Figures

Figure 1	Site Location	1
Figure 2	Local Context.....	2
Figure 3	Proposed Development	3
Figure 4	Site Context.....	8
Figure 5	Local Highway Network.....	9
Figure 6	JTC Survey Locations	13
Figure 7	PIC Study Area and Collision Locations	14
Figure 8	Proposed Development	17
Figure 9	Site Access Arrangements	18
Figure 10	Parking Arrangements – George Street & Mitchell Street	20
Figure 11	Local Amenities	22
Figure 12	Local Roads and Paths	24
Figure 13	Extract of Gateshead Cycle Map	25
Figure 14	Local Bus Stops	26
Figure 15	Surveyed Locations	28
Figure 16	Identified Issue Location.....	30
Figure 17	Trip Assignment	40
Figure 18	Trip Assignment – % Leaving the Site	41
Figure 19	Modelled Junctions	42
Figure 20	A167 / Lamesley Road Priority Junction	45
Figure 21	A167 / Edward Road Priority Junction	47
Figure 22	George Street / Station Lane Priority Junction	48
Figure 23	A167 / Birtley Lane / Craig Street Signal-Controlled Junction.....	49
Figure 24	A167 / Station Lane / The Avenue Signal-Controlled Junction.....	50

Tables

Table 3.1	Summary of Surveyed Traffic Flows.....	13
Table 3.2	PIC Study Summary.....	15
Table 4.1	Gateshead Council Car Parking Guidance	19
Table 5.1	Local Bus Services.....	27
Table 6.1	2011 Audit – Identified Issues.....	29

Table 6.2	Responses and Comments to Identified Issues	31
Table 7.1	Initial Travel Plan Targets	34
Table 8.1	Mean Residential Trip Rates (per dwelling)	36
Table 8.2	Trip Generation (per 292 dwellings)	37
Table 8.3	12 and 16-Hour Trip Rates	37
Table 8.4	Anticipated Place of Work	38
Table 8.5	Trip Distribution and Assignment.....	39
Table 9.1	A167 / Lamesley Road Priority Junction Assessment Summary	46
Table 9.2	A167 / Edward Road Priority Junction Assessment Summary	47
Table 9.3	George Street / Station Lane Priority Junction Assessment Summary	48
Table 9.4	A167 / Birtley Lane / Craig Street Signal-Controlled Junction Assessment Summary	49
Table 9.5	A167 / Station Lane / The Avenue Signal-Controlled Junction Assessment Summary	50

Appendices

Appendix 1	Proposed Masterplan
Appendix 2	TADU PIC Locations
Appendix 3	Parking Survey
Appendix 4	Swept Path Analysis
Appendix 5	TRICS output
Appendix 6	2011 Census Data
Appendix 7	2022 Observed Flows
Appendix 8	2028 Baseline Flows
Appendix 9	Proposed Development Traffic Flows
Appendix 10	Committed Development Traffic Flows
Appendix 11	2028 Total Traffic Flows
Appendix 12	Junctions 9 Outputs
Appendix 13	LinSig Controller Specifications
Appendix 14	LinSig Outputs

1. Introduction, Background & Scope

Introduction

- 1.1 Milestone Transport Planning Ltd (MTP) has been appointed by Gleeson Regeneration Ltd to prepare this Transport Assessment (TA) and Travel Plan (TP) to accompany a planning application for 292 residential dwellings on the former BAE Systems site, west of Ravensworth Road, Birtley, Gateshead.
- 1.2 It should be noted that detailed pre-application discussions were undertaken with Gateshead Council (GC), the results of which informed an initial TA and TP document.
- 1.3 Following further discussions with GC this report provides updates and includes revisions to the initial TA and TP, whilst also responding to a number of comments raised, in particular those regarding the proposed accesses and internal layout of the site. This revision also provides junction impact assessments at number of agreed junctions to fully assess the impact of development related traffic on the local highway network.
- 1.4 It's of particular note that the minor layout changes have seen an overall reduction of 6 dwellings across the development, from 298 to 292, since the initial TA was submitted. The previous trip generation, distribution and assignment exercises were based on a site of 298 dwellings, and given the relatively small reduction in dwelling numbers, the original trip analysis is deemed as representative and robust for the assessment of the potential impact of the development on the local highway network.
- 1.5 The site is situated approximately 550m northwest of Birtley town centre and 1.3km southwest of the A1(M). In terms of the wider context, the site is approximately 8.5km south of Newcastle and 13km north of Durham. The location of the site is shown in Figure 1.

Figure 1 Site Location

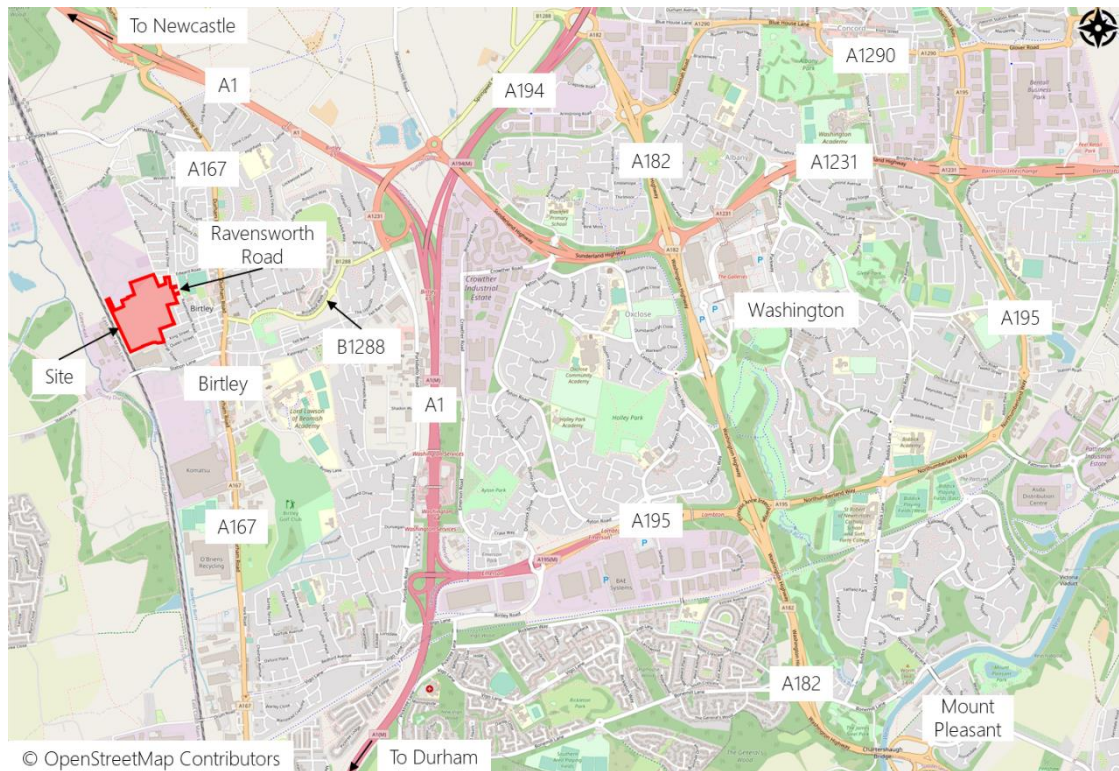

Background

- 1.6 The application site is approximately 11.2ha in size and was formerly occupied by BAE Systems. A planning application for 229 houses and a retained building for community uses with associated infrastructure was submitted in 2011 (GC planning application reference: DC/11/00546/OUT). The previous application was submitted on behalf of BAE Systems to redevelop their site for residential use and, whilst approved, this was not brought forward.
- 1.7 Following the cessation of the BAE Systems operations on the site, Gleeson Regeneration Ltd (“the Developer”) is now proposing to recommence the plans to redevelop it for residential purposes. The site, in terms of its local context, is shown in Figure 2.

Figure 2 Local Context

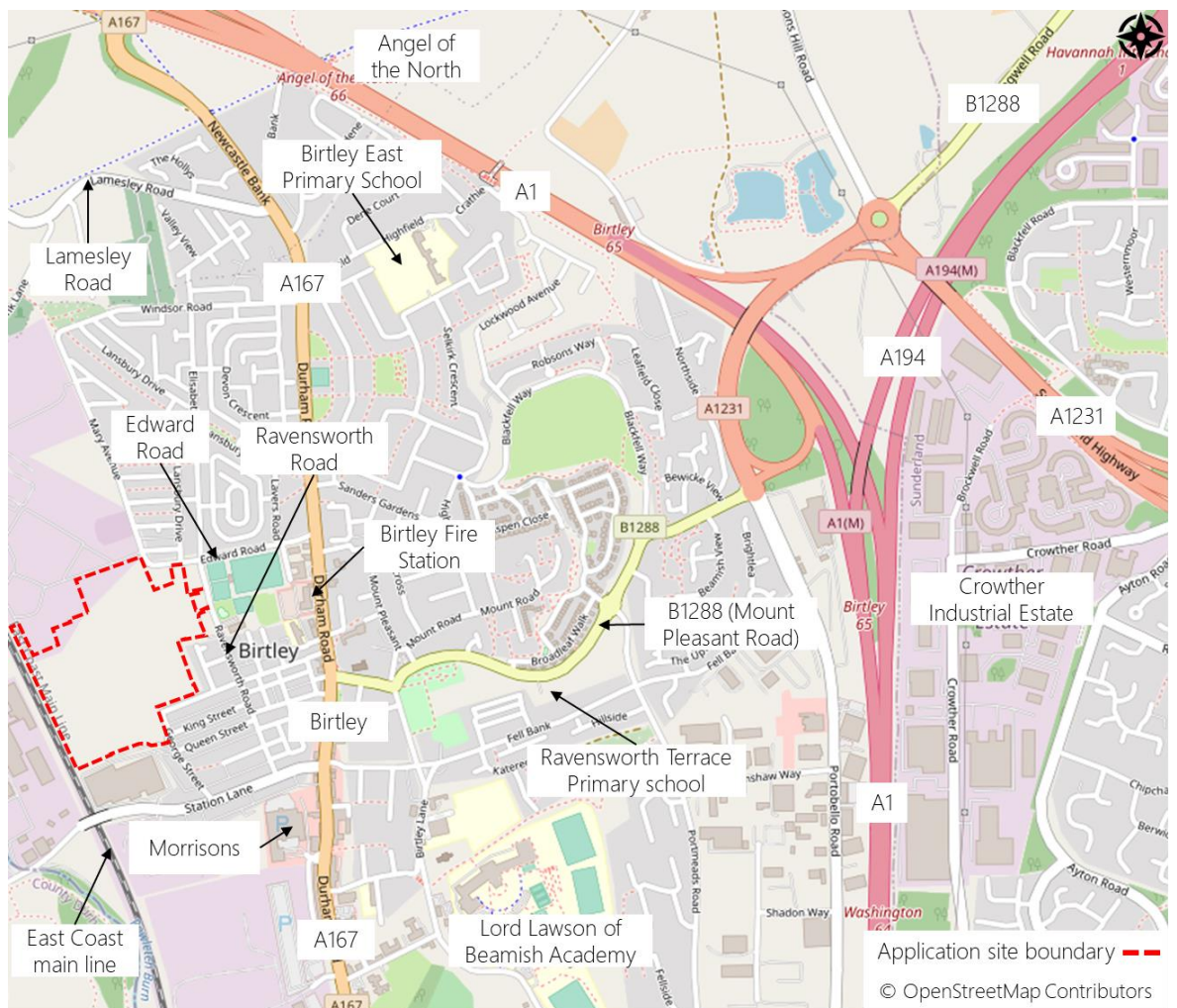

- 1.8 This proposal is for a residential development of 292 dwellings and two vehicle accesses, one onto Edward Road to the northeast of the site and one where Mitchell Street meets George Street to the southeast of the site.
- 1.9 It is understood that the proposed vehicle accesses to the site will make use of the existing site accesses to the north and south that are currently secured with lockable gates.

1.10 It is also understood that additional pedestrian accesses will be available via existing accesses, one of which is currently closed and secured by lockable gates. Both accesses provide links to Ravensworth Road.

1.11 Figure 3 shows an extract of the masterplan for the proposed development and highlights the proposed vehicular and pedestrian accesses. A full version of the proposed masterplan is attached as Appendix 1.

Figure 3 Proposed Development



Scope of Report

1.12 The purpose of this TA and TP is to consider the proposed development in highway and transportation terms by assessing the implications of travel, associated with the development, on the operation and safety of the surrounding highway network.

1.13 The remaining sections within this report comprise of:

- Section 2 considers the development proposal in the context of relevant planning policies at a national and local level;
- Section 3 provides a description of the site and surrounding area, details of the baseline highway and transport conditions, and a review of traffic accident records on the local highway;
- Section 4 details the development proposals including the proposed access strategy and parking arrangements;

- Section 5 considers the site accessibility by sustainable modes of transport;
- Section 6 outlines the Travel Plan to minimise the traffic impact from the development;
- Section 7 considers the trip generation and resultant traffic impact of the development;
- Section 8 provides an overview of arrangements for the construction phase, and;
- Section 9 provides a summary and conclusions.

2. Planning Policy Context

National Planning Policy Framework (2021)

- 2.1 The Ministry of Housing Communities & Local Government published the revised National Planning Policy Framework (NPPF) in July 2021. A key thread of NPPF is to promote sustainable transport and paragraph 104 highlights the importance of considering transport issues to ensure that:
- Potential impacts on transport networks can be assessed;
 - Opportunities from existing and proposed transport infrastructure, changing transport technology and usage are realised;
 - Opportunities to promote walking, cycling and public transport use are identified and pursued;
 - Environmental impacts of traffic and transport infrastructure are identified, assessed and considered – identifying opportunities for avoiding and mitigating any adverse effects and for net environmental gains; and
 - Patterns of movement, streets, parking and other transport considerations are integral to the design of schemes and contribute to making high quality places.
- 2.2 Paragraph 105 goes on to state that: *"The planning system should actively manage patterns of growth...Significant development should be focused on locations which are or can be made sustainable, through limiting the need to travel and offering a genuine choice of transport modes..."*
- 2.3 Paragraph 110 requires specific allocations for development to ensure that:
- Appropriate opportunities to promote sustainable transport modes have been taken up;
 - Safe and suitable access to the site can be achieved for all users;
 - The design of streets, parking areas, other transport elements and the content of associated standards reflects current national guidance, and;
 - Any significant impacts from the development on the transport network (in terms of capacity and congestion), or on highway safety, can be cost effectively mitigated to an acceptable degree.
- 2.4 Paragraph 111 continues to state that *'...developments should only be prevented or refused on highway grounds if there would be an unacceptable impact on highway safety, or the residual cumulative impacts on the road network would be severe'*.
- 2.5 Paragraph 112 requires that applications for development should:
- First, give priority to pedestrian and cycle movements, both within the scheme and with neighbouring areas;
 - Second, so far as is possible, facilitate access to high quality public transport, maximising catchment areas to services and implementing appropriate facilities to encourage use;
 - Address the need of people with disabilities and reduced mobility;
 - Create places that are safe, secure and attractive which minimise conflicts between pedestrians, cyclists and vehicles;
 - Allow for the efficient delivery of goods and access by service and emergency vehicles; and

- Be designed to enable charging of plug-in and other ultra-low emission vehicles.

Core Strategy & Urban Core Plan for Gateshead & Newcastle 2010-2030

- 2.6 The 'Core Strategy and Urban Core Plan for Gateshead and Newcastle 2010-2030' was adopted by GC in March 2015 and is the first stage of the Local Plan.
- 2.7 As the site is outside the identified Urban Core then the most up to date Core Strategy is relevant. Policy CS1 'Spatial Strategy for Sustainable Growth' states that all development should be:
- Well-connected and accessible by sustainable modes of transport;
 - Well designed to promote community cohesion, wellbeing, and to reflect and enhance the area's character and natural environment; and
 - Designed to reduce carbon emissions and adapted to the effects of climate change.
- 2.8 Policy CS13 'Transport' strives to ensure developments:
- Which generate significant movement is located where the use of sustainable transport modes can be maximised;
 - Minimises car trips, promotes and enhances public transport and for major development provides sustainable travel plans;
 - Connects safely to and mitigates the effects of development on the existing transport networks;
 - Provides cycle parking and supporting infrastructure; and
 - Provides for direct, safe, secure and continuous pedestrian and cycling links.

Gateshead Council Making Spaces for Growing Places

- 2.9 The Making Spaces for Growing Places (MSGP) was adopted by Gateshead Council in February 2021. The document sets out borough-wide policies for managing development together with site allocations and designations and will form part of Gateshead's Local Plan.
- 2.10 Policy MSGP16 sets out how new developments must demonstrate their acceptability by producing a Transport Assessment / Statement and Travel Plan to support their proposals and promote sustainable transport.
- 2.11 Policy MSGP17 then goes on to set out the transport aspects of all new developments, by requiring them to:
- 1) secure safe access to the site for all people and provide adequate servicing facilities;*
 - 2) not have an adverse impact on the safe operation of the transport network, or a severe residual impact on the efficient operation of the road network, or levels of congestion;*
 - 3) give priority to access by sustainable travel including the improvement of existing links and the removal of barriers to sustainable means of access and;*
 - 4) protect, and where necessary, enhance the public right of way and cycle networks. Where it is necessary to disturb either network, suitable replacement sections of route will be required; and*

5) provide the level of parking necessary to secure the safe and effective operation of the development by:

a. providing car parking for residential development to the levels set out in the Council's parking standards;

b. limiting car parking for non-residential development in line with the Council's parking standards;

c. providing electric vehicle charging points in line with the Council's parking standards;

d. providing motorcycle parking facilities in line with the Council's parking standards;

e. providing cycle parking facilities in line with the standards set out in the Council's cycle parking standards."

2.12 The production of this TA and TP ensures the development complies with MSGP16 and the content of the document will demonstrate how it complies with MSGP17.

Summary

2.13 Overall, National and Local policy has a focus on delivering goals for sustainable communities and transport, which reflect local land use plans, economic development and climate change priorities.

2.14 It is considered that the site is very well located for residential development in planning policy terms and this TA and TP will demonstrate this by way of a thorough assessment of its sustainability credentials and assessment of its impact upon the highways and transportation networks.

3. Baseline Conditions & Site Accessibility

Site Context

- 3.1 The site is located approximately 550m northwest of Birtley town centre and occupies approximately 11.2ha of land. It is bounded to the north and south by industrial units, an existing residential estate to the east and the East Coast Main Line to the west.
- 3.2 The immediate area is predominantly industrial in character with some occupied and vacant premises to the north and south of the site. Existing residential estates to the east separate the existing industrial units from the A167.
- 3.3 The location of the site is shown in Figure 4.

Figure 4 Site Context

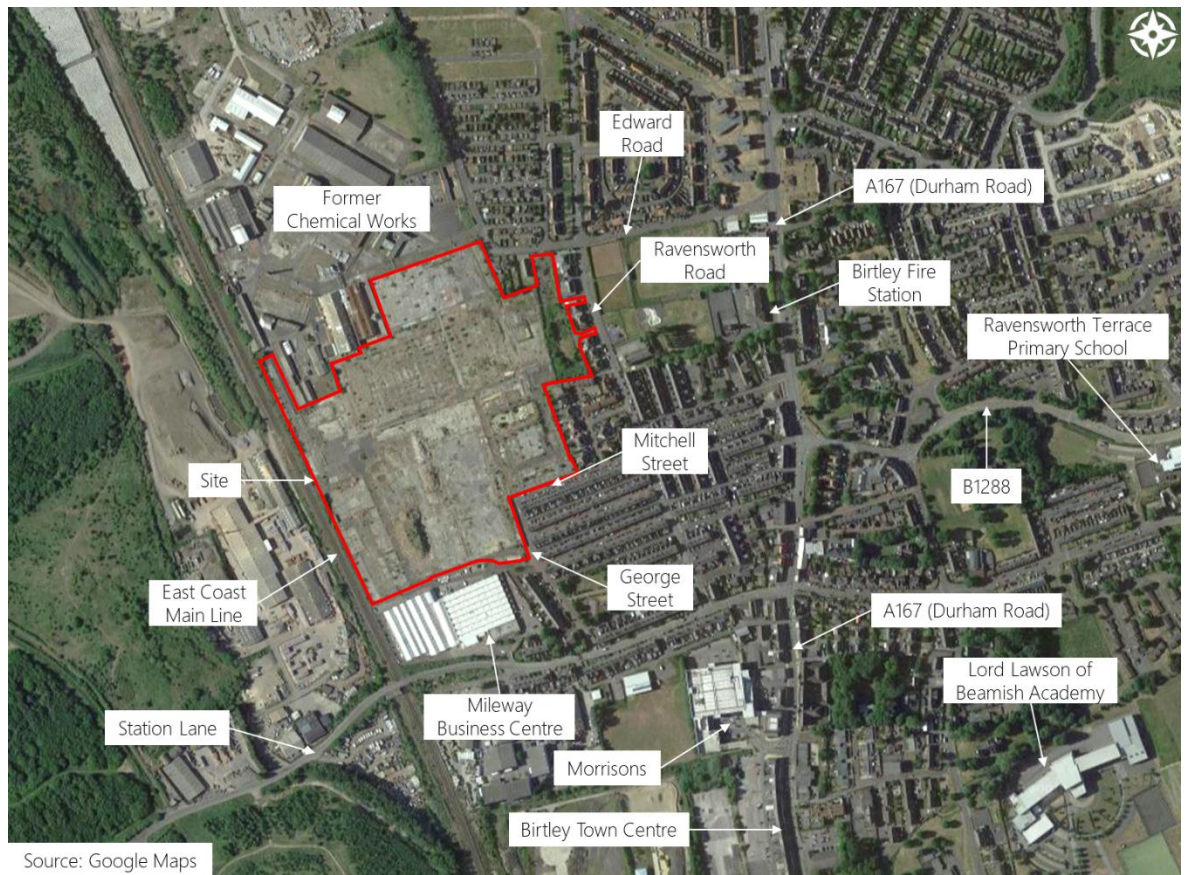

- 3.4 It is understood that the buildings associated with the previous operation of the former BAE Systems site have already been demolished, as such the site is currently undeveloped and does not generate any traffic movements on the surrounding highway network.

Local Highway Network

- 3.5 The site in the context of the local highway network is shown in Figure 5.

Figure 5 Local Highway Network

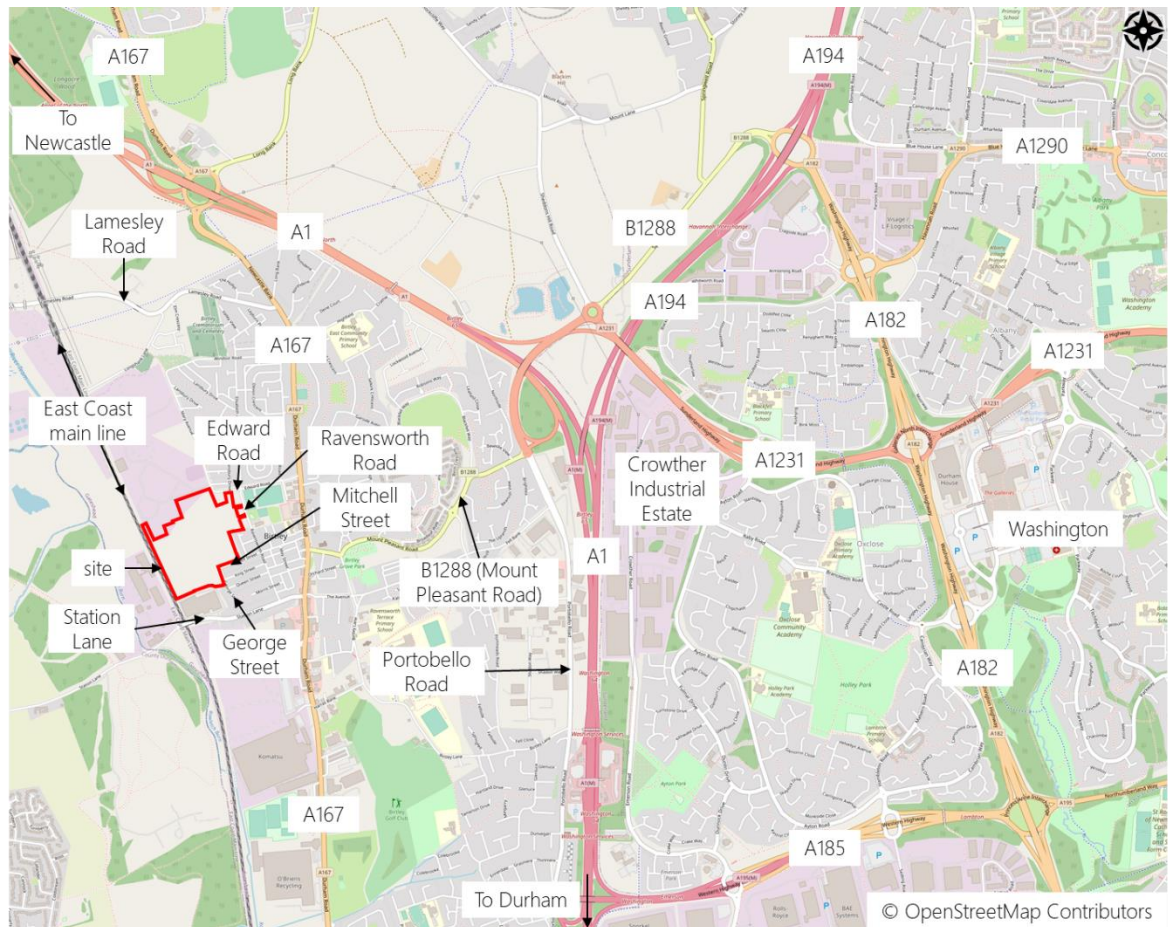

- 3.6 Proposed vehicle access to the site is to the north at a junction with Edward Road and to the south at a junction with Mitchell Street and George Street. Two traffic-free pedestrian accesses are also proposed on Ravensworth Road.

Residential Road Network East of the Site

- 3.7 The site can be accessed by various modes of transport from Edward Road, Ravensworth Road and Mitchell Street/George Street. These routes provide links throughout the residential area to the east and south east of the site and link to the A167 Durham Road to the east and Station Lane to the south, via priority junctions.
- 3.8 Ravensworth Road, Mitchell Street and George Street provide the links to the A167 and Station Lane. They are all subject to 20mph speed limits and have footways and streetlighting on both sides of their carriageways. These roads also have sets of speed cushions to further enforce the 20mph speed limit.
- 3.9 Edward Road is also subject to a 20mph speed limit and has footways and streetlighting on both sides of the carriageway.
- 3.10 Each of these roads are primarily fronted by residential properties, although Edward Road also serves some light industrial/business units.

- 3.11 Overall, the highway network to the east of the site comprises an extensive network of residential roads which provide links to the A167 and Station Lane.

Station Lane

- 3.12 Station Lane runs predominantly east-west and provides links to the A167 in the east and the settlements of Ouston, Perkinsville and Pelton to the southwest.
- 3.13 In the vicinity of the site, Station Lane is fronted by residential properties and industrial/business units and has footways and streetlighting on both sides of the carriageway.
- 3.14 In the vicinity of the site the route is subject to a 20mph speed limit, but towards the bridge over the East Coast Main Line the limit changes to 30mph.

A167

- 3.15 The A167 provides links to Newcastle in the north and Darlington in the south and is the main road through Birtley town centre. The route runs parallel to the A1 and provides access to a large range of residential, industrial and retail areas, including the main shopping area within Birtley. The route also connects to the A1(M) north of Birtley and provides access to a number of urban areas including Durham, Chester-Le-Street, and Gateshead.
- 3.16 Through Birtley, the route is a good standard single carriageway subject to a mix of 20mph and 30mph speed limits. Carriageway widths typically vary between 7m and 10m and there are footways on both sides. There is a predominantly on-carriageway cycle route on both sides of the road and several bus stops in either direction. There are also numerous pedestrian crossing points including zebra crossings, puffin crossings and uncontrolled crossings, some with refuge islands.
- 3.17 North of Birtley, at the roundabout with the A1, the route is subject to a 40mph speed limit. The carriageway also has a bus lane and shared cycleway/footways on both sides. The route then continues into Low Fell where it is subject to a 30mph speed limit and continues on to Gateshead and Newcastle.
- 3.18 South of Birtley, the route is subject to mainly a 30mph speed limit that changes to 40mph at the roundabout with Vigo Lane. The carriageway has shared footways/cycleways and a number of bus stops on each side of the carriageway. The route then continues south towards Durham and Darlington via a mix of single and dual carriageways.

B1288 (Mount Pleasant Road)

- 3.19 The B1288 is located to the east of the site and links to the A167 from a signal controlled junction. The route has a carriageway width of c.7.3m with lighting and a footway/cycleway on the south side. There are also a number of bus stops in laybys along the route.
- 3.20 Northeast of the A167 junction the route meets Maple Avenue and Portmeads Road (a local distributor through central Birtley) at a roundabout and then continues northeast.
- 3.21 The B1288 then meets Blackfell Way at a 3-arm roundabout. East of the roundabout, the route meets the A1231, which runs through eastern Birtley and also offers the most direct links to Wrekenton, Washington, Sunderland, the A1(M) and the A194(M).

- 3.22 From the junction with the A167 and Birtley Lane the route is subject to a 20mph speed limit and just south of the roundabout with Blackfell Way the speed limit increases to 30mph.
- A1(M)**
- 3.23 The A1/ A1(M) forms part of England's Strategic Road Network (SRN) and as such is maintained by National Highways (NH). North of the site, the A1 continues north towards Newcastle and onwards to Scotland. To the south, the route is of a Motorway standard and therefore is known as the A1(M), between Gateshead and Scotch Corner.
- 3.24 Within the vicinity of the site, the A1 is generally subject to 50mph speed limit, although it increases to the national speed limit southbound around Junction 66. The northbound carriageway has three lanes, with one forming a lane gain / lane drop arrangement between the A1231 'northbound loop' and Junction 66. The southbound carriageway has three running lanes.
- 3.25 Junction 66 is a 5-arm grade separated part-signalised roundabout with the A1 bridged over. The roundabout has north and southbound facing slip roads, with the A167 forming the two other main arms. The fifth arm is the B1296 which links the A1 to Wrekenton.
- 3.26 Junction 67 operates in similar manner to Junction 66. It is also part signalised with the A1 travelling over and having north and southbound slip roads. This junction serves as one of the main accesses into Team Valley Trading Estate via Kingsway South. There are two smaller roads, including Chowdene Bank that serves a Sainsburys and residential areas within Low Fell and Banesley Lane that links to rural areas towards Old Ravensworth.
- 3.27 At the time of writing, NH has started an upgrade of the A1, with the 'A1 Birtley to Coal House Road improvement scheme' which is due to complete in 2025.
- 3.28 The improvement scheme includes approximately four miles of upgrades between Junction 65 and 67. The existing road will be widened and additional lanes added to help manage traffic joining and leaving the A1, including:
- Northbound lanes will be increased from two to three lanes, and;
 - Southbound lanes will increase from three to four.
- 3.29 As part of the proposals, the Allerdene railway bridge will be replaced, which carries the A1 over the East Coast Mainline.
- 3.30 Key aims of the improvement scheme are to benefit road users and local communities, and to support the region's economy. Once completed, NH envision that the benefits from the scheme will include:
- Reducing congestion by increasing capacity for road users;
 - Improving the reliability of people's journeys and reducing delays by increasing the capacity of the road network;
 - Making journeys safer by improving the standard and capacity of the road;
 - Helping to support economic growth by improving the road to the Newcastle and Tyneside area, and;
 - Supporting the government's initiative for growth in the north.

A194(M)

- 3.31 The A194(M) links the A1 to South Tyneside and can be joined via the B1288 (Mount Pleasant Road).
- 3.32 North of the A1(M) Washington services, the route branches and continues north to the Felling Bypass and on to South Shields. In the north, the A194(M) also provides links to the A19.

Highway Network Summary

- 3.33 Overall, the local highway network has a varied character which ranges from motorways and dual carriageways to distributor roads and residential access roads.
- 3.34 In summary, the site is therefore well connected to the surrounding highway network through two vehicular and two traffic-free pedestrian accesses, which provide connections to a large range of local and regional routes.

Existing Traffic Flows

- 3.35 For the purposes of the initial version of the TA, and due to the impacts of the Covid-19 pandemic, restrictions on travel and general 'work from home' advice it had not been possible to obtain representative, up-to-date, traffic flow data for the local highway network. As such, Annual Average Daily Traffic (AADT) information had been obtained for four locations in the vicinity of the site, from counter sites maintained by the Department for transport (DfT). The DfT data previously obtained indicated that in general traffic flows had been increasing (prior to the Covid-19 pandemic). Based on the data, it was considered that there are no existing issues with the capacity of the road network surrounding the site.
- 3.36 Following recent comments from GC, it was requested that a review of AADT from Gateshead Traffic and Accident Data Unit (TADU) would be more representative of the local traffic flows in the vicinity of the site. Having reviewed the available data on the TADU website, it was considered to be lacking some information at similar locations that had already been considered. As such, it was considered that these flows do not provide fully representative and up-to-date traffic flows in the vicinity of the site.
- 3.37 As the previous version of the TA stated that junction assessments would be required to fully assess the impact of the development traffic on the local highway network, a number of traffic surveys were agreed with GC and commissioned to take place on the 9th May 2022. These surveys provide data for the existing traffic flows in the vicinity of the site. The junction assessments will be discussed fully at a later stage of the TA.
- 3.38 The commissioned surveys include five junction turning counts (JTCs) which collected traffic flow data for the AM and PM peak periods. Although, data has been obtained for the AM and PM peaks only, it is still considered that these flows are representative of the current travel patterns on the local highways.
- 3.39 As such, the peak flows from the surveys have been converted to Annual Average Daily Flows (AADF) using the methodology set out in 'Transport in the Urban Environment'. The PM peak flows have been used as they generally provide higher traffic flows, therefore are considered to be more robust for the purposes of this report.
- 3.40 The methodology states that to convert peak hour flows into AADF, the peak flows should firstly be divided by a factor of 2.630, to find the annual average hourly flow (AAHF). The AAHF should then be multiplied by 24 to find the AADF.

3.41 Figure 6 shows the location of the junctions that have been surveyed and Table 3.1 provides a summary of the two-way peak hour flows and AADF for each of the arms that have been surveyed.

Figure 6 JTC Survey Locations

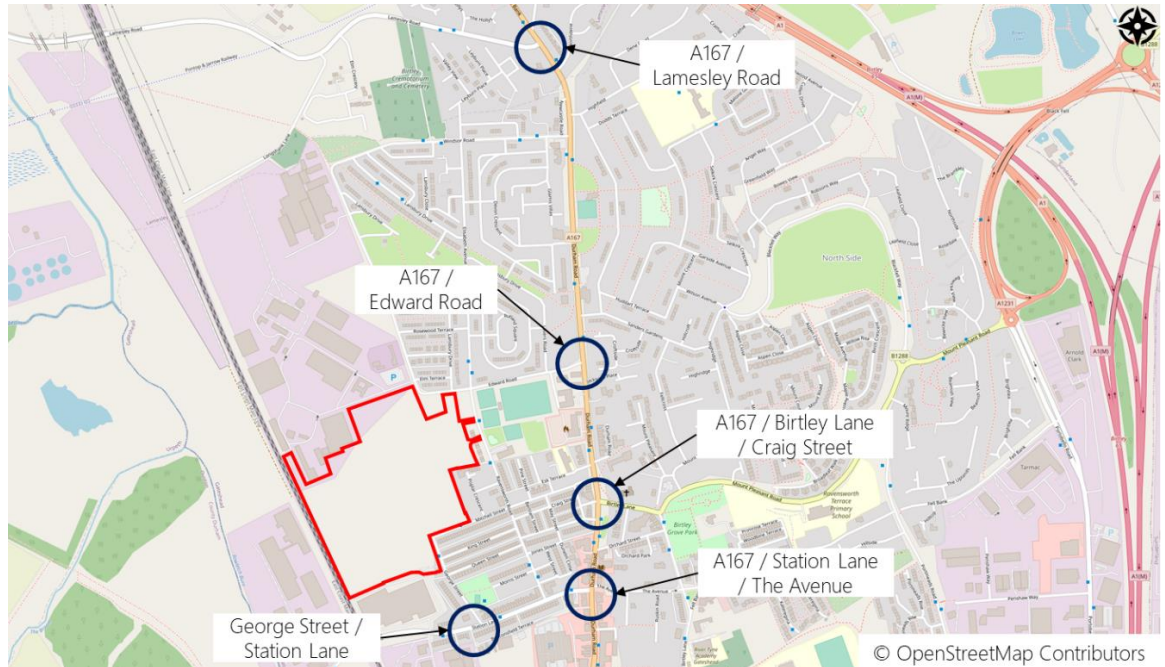

Table 3.1 Summary of Surveyed Traffic Flows

Location / Arm	Total Two-Way Flows (per arm)			Location / Arm	Total Two-Way Flows (per arm)		
	AM Peak	PM Peak	AADF		AM Peak	PM Peak	AADF
A167/Lamesley Road				A167/Birtley Lane/Craig Street			
A167 (N)	887	1,148	10,476	A167 (N)	944	1,088	9,925
Lamesley Road	681	656	5,985	Birtley Lane	596	573	5,231
A167 (S)	1,275	1,403	12,802	A167 (S)	786	1,094	9,987
A167/Edward Road				Craig Street 16 1 9			
A167 (N)	969	1,148	10,472	A167/Station Lane/The Avenue			
Edward Road	184	166	1,513	A167 (N)	807	1,096	10,001
A167 (S)	938	1,073	9,789	The Avenue	195	95	867
George Street/Station Lane				A167 (S) 941 1,133 10,343			
George Street	36	34	312	Station Lane	770	658	6,004
Station Lane (E)	643	623	5,687				
Station Lane (W)	647	620	5,656				

- 3.42 As shown, the A167 is a highly trafficked route, which is predicted to have roughly 20,000 two-way vehicle trips between the junction with Lamesley Road and the junction with Station Lane/The Avenue. The highest number of two-way trips predicted on the A167 is approximately 23,278 two-way vehicle at the Lamesley Lane junction, with the lowest number of trips predicted to be 19,912 two-way movements per day at the junction with Birtley Lane/Craig Street.
- 3.43 The surveys also show that there are no major capacity issues within Birtley in terms of queuing during the peak periods. Although it is noted that queues are present, with a minimum queue of 1 vehicle recorded and a maximum queue of 20 vehicles being recorded on a signal controlled arm.
- 3.44 Outside of these surveys, to the north of the A167 there are links to the A1, where during peak times there are known congestion issues, although these issues will be addressed through the ongoing NH improvement schemes.
- 3.45 Overall, it is considered that there are no existing issues with the capacity of the surrounding network that are not already being addressed by ongoing improvement schemes on the Strategic Road Network.

Traffic Accident Review

- 3.46 Personal Injury Collision (PIC) data has been obtained from the Gateshead TADU for the period of 1st March 2015 – 1st December 2021. The data provides the most recent data for a 6.5 year period including five years of data prior to the Covid-19 pandemic. The study area and collision locations are shown in Figure 7.
- 3.47 PIC location data is included in Appendix 2. Detailed data is not attached due to GDPR considerations, but can be provided to the council data on request. A summary of each collision is provided in Table 3.2.

Figure 7 PIC Study Area and Collision Locations

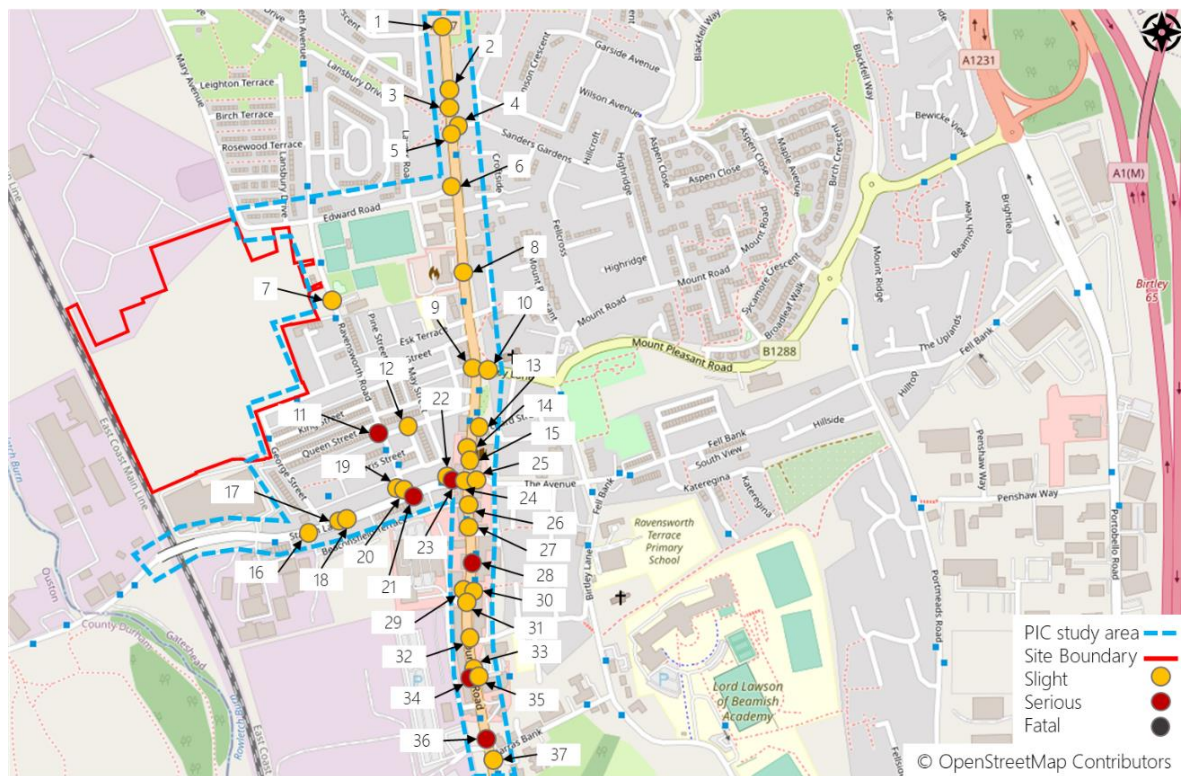

Table 3.2 PIC Study Summary

Ref	Date/Time	Conditions	Severity	Vehicles	Details
1	18.01.17 / 08:45	Daylight / Fine / Dry	Slight	Car / Pedestrian	P1 emerged from stationary traffic into path of V1.
2	22.06.17 / 14:55	Daylight / Fine / Dry	Slight	Car / Car	V1 collided with rear of V2 waiting to turn right.
3	19.12.18 / 11:40	Daylight / Dine / Damp	Slight	Goods vehicle <3.5 tonnes / Pedestrian	GV1 collided with P1 as they crossed the road.
4	30.07.15 / 12:15	Daylight / Fine / Dry	Slight	Car / Cyclist	V1 turned left and collided with C1.
5	21.02.19 / 07:30	Daylight / Fine / Dry	Slight	Goods vehicle <3.5t / Pedestrian	V1 turned left and collided with P1.
6	15.12.17 / 12:56	Daylight / Fine / Dry	Slight	Car / Cyclist	V1 turned right and collided with C1.
7	14.02.19 / 08:27	Daylight / Fine / Dry	Slight	Car / Goods vehicle <7.5t	V1 slowed as if to so a three point turn, GV1 applied brake but collided with nearside of V1.
8	17.06.21 / 11:45	Daylight / Fine / Dry	Slight	Goods vehicle <3.5t / Pedestrian	GV1 had trailer loaded with cable reel in tow, cable reel detached from trailer and collided with P1.
9	09.12.15 / 17:55	Darkness / Fine / Dry	Slight	Car / Car	V1 collided with rear of V2 at traffic lights.
10	16.06.16 / 16:00	Daylight / Fine / Dry	Slight	Goods vehicle / Car	GV1 collided with rear of V1.
11	11.09.16 / 16:25	Daylight / Fine / Dry	Serious	Motorcycle / Car	M1 failed to stop at junction and collided with V1.
12	26.06.15 / 15:37	Daylight / Fine / Dry	Slight	Goods vehicle <3.5t / Pedestrian	P1 emerged into the path of GV1.
13	11.05.15 / 15:20	Daylight / Fine / Dry	Slight	Car / Cyclist	V1 turned left and collided with C1.
14	02.10.18 / 17:32	Daylight / Fine / Dry	Slight	Car / Pedestrian	P1 ran into path of V1.
15	11.12.17 / 16:00	Daylight / Fine / Dry	Slight	Vehicle unknown / 2 Pedestrians	V1 pulled onto A167 and collided with pedestrians.
16	26.01.18 / 15:07	Daylight / Fine / Dry	Slight	Car / Car	V1 left junction and collided with V2.
17	28.04.16 / 01:06	Daylight / Fine / Dry	Slight	Bus / Pedestrian	B1 pulled into bus stop, wing mirror clipped P1.
18	04.01.20 / 22:09	Darkness / Fine / Damp	Slight	Goods vehicle / Car	GV1 collides with offside rear of V1 which then lost control and spun.
19	14.03.19 / 07:30	Daylight / Fine / Dry	Slight	Car / Goods vehicle <3.5t	GV1 stopped at junction, V1 undertook and mounted the pavement, collided with nearside of GV1 then drove off at speed.
20	09.08.16 / 16:05	Daylight / Fine / Dry	Slight	Car / Pedestrian	V1 reversed into P1 crossing the road.
21	17.08.20 / 16:34	Daylight / Fine / Dry	Serious	Goods vehicle >7.5t / Pedestrian	P1 ran in between parked vehicles into path of GV1.
22	14.02.19 / 18:55	Darkness / Fine / Dry	Slight	Car / Pedestrian	P1 walked into path of V1.
23	28.08.15 / 09:00	Daylight / Fine / Dry	Serious	Goods vehicle >7.5t / Pedestrian	GV1 turned right and collided with P1.
24	08.12.19 / 12:15	Daylight / Fine / Damp	Slight	Car / Car	V1 collides with side of V2 as it entered the junction.
25	20.06.17 / 07:20	Daylight / Fine / Dry	Slight	Car / Cyclist	V1 turned right and collided with C1.
26	26.07.20 / 13:05	Daylight / Fine / Dry	Slight	Car / Bus	V1 stopped late, B1 applied brake sharply to avoid collision, passenger on B1 injured leg.
27	11.09.15 / 15:45	Daylight / Fine / Dry	Slight	Car / Cyclist	V1 turned right and collided with C1.
28	07.07.21 / 14:00	Daylight / Fine / Dry	Serious	Car / Pedestrian	V1 collided with P1 crossing the road
29	31.08.16 / 12:50	Daylight / Fine / Dry	Slight	Car / Pedestrian	P1 walked into the path of V1.
30	17.07.20 / 23:50	Darkness / Fine / Dry	Slight	Car / Car	V2 reversed onto A167, V1 travelled at speed and collided with V, causing both vehicles to spin.
31	08.12.15 / 08:45	Daylight / Fine / Dry	Slight	Goods vehicle >7.5t / Bus	B1 applied brake to avoid GV1, passenger on B1 injured.
32	08.06.19 / 14:20	Daylight / Fine / Damp	Slight	Car / Pedestrian	V1 attempted a three-point turn and collided with P1 on the pavement.

33	07.09.18 / 12:20	Daylight / Rain / Wet	Slight	Goods vehicle <3.5t / Goods vehicle <3.5t	V1 collided with rear of V2.
34	22.08.18 / 17:25	Daylight / Fine / Dry	Serious	Bus / Pedestrian	P1 (child) ran into the side of B1.
35	18.05.18 / 08:29	Daylight / Fine / Dry	Slight	Car / Cyclist	C1 collided with V1 as it turned left.
36	10.05.21 / 18:20	Daylight / Fine / Damp	Serious	Motorcycle / Car	V1 stationary at traffic lights, M1 approached and applied brake but skidded due to surface water and the driver came off.
37	08.04.20 / 19:25	Daylight / Fine / Dry	Slight	Car / Motorcycle	V1 and M1 collided mid junction, both stated they passed through on a green light.

3.48 Overall, there were 37 PICs within the study area between March 2015 and December 2021. Key points from a review of these incidents can be summarised as follows:

- There were thirty-one slight and six serious collisions. No fatal incidents were recorded study area;
- Twenty-two of the PICS involved a pedestrian or cyclist and twelve incidents involved a HGV;
- Of the collisions the main causes were from vehicles turning into/out of a junction (ten incidents), a lack of concentration (nine incidents) and five as a result of poor manoeuvring / overtaking.
- Thirty-three of the collisions occurred during daylight hours;
- Three PICs occurred in the residential estate to the west of the A167 and between Edward Road and Station Lane, including one serious and two slight incidents. These collisions can be attributed to poor manoeuvring and a lack of concentration;
- Six PICs occurred on Station Lane to the west of the junction with the A167, including five slight and one serious collision. The slight collisions can be attributed to driver error or lack of concentration. The serious collision was as a result of a pedestrian running out into the path of a HGV from between two parked cars;
- There were nine slight collisions on the A167 to the north of the Station Lane junction which can be attributed to either a lack of concentration from a driver/pedestrian and an incident where a cable reel became detached from a trailer and injured a pedestrian;
- There were seven incidents in the vicinity of the Station Lane junction with the A167, including one serious and six slight collisions. Of which, five can be attributed to poor manoeuvring or lack of concentration and two were as a result of a pedestrian walking out into the path of a vehicle, and;
- There were twelve collisions on the A167 south of the Station Lane junction including three serious and nine slight incidents. Of these, nine can be attributed to driver error, including speeding, lack of concentration and poor manoeuvring. Two incidents were due to a pedestrian walking into the path of a moving vehicle, and one was as a result of surface water causing a motorcycle to skid.

3.49 The overall number of incidents when spread across the 6.5 year period is not considered unusual for a busy urban highway network. Especially when most of the incidents are due to a lack of concentration or driver error and not as a result of the road layout.

3.50 In summary, the number of incidents within the study area is within normal expectations for the urban character of the road network, at around six per year.

3.51 As such, the review confirms there are no patterns or clusters of incidents that would raise concern in the context of the proposed residential development.

4. Proposed Development & Access Strategy

4.1 The proposed development comprises 292 residential dwellings and an extract of the development layout is shown in Figure 8 and is included, in full, as Appendix 1.

Figure 8 Proposed Development



Source: Edward Architecture

4.2 The proposed housing and parking mix within the development masterplan is as follows:

- 52 two bed units;
- 188 three bed units;
- 52 four bed units;
- 464 allocated parking spaces (and 108 garages), and;
- 79 visitor parking spaces.

Proposed Access Arrangements

- 4.3 It is proposed that the development will be served by vehicular accesses to the north and south and two traffic-free pedestrian access to the east, as shown in Figure 9.

Figure 9 Site Access Arrangements



- 4.4 Vehicular access to the development would be from Edward Road in the northeast corner and Mitchell Street/George Street in the southeast corner. It is understood that both of these accesses will make use of existing gated accesses through modifications to create purpose built priority junctions.
- 4.5 Both vehicle accesses have been designed offer visibility splays of at least 2.4m x 25m in both directions to comply with the requirements of the Manual for Streets (MfS) for speeds of up to 20mph. The internal layout will also be subject to a 20mph speed limit and will have an internal carriageway width of 5.5m. To allow for an internal 20mph speed limit, the developer will work with GC to amend the existing Traffic Regulation Order (TRO).
- 4.6 In addition to vehicular accesses, there will be two further non-vehicular links at Ravensworth Road which will link into existing footways and access links to connect to the wider residential area to the east of the site. The southern link will be 3m wide and will form a pedestrian and cycle link through the site that complies with LTN 1/20.
- 4.7 All of the access points will be linked through the development and there will be footways provided to give access to each dwelling within the development.
- 4.8 Overall, the development will be very well connected to the surrounding highway network.

Parking Provision

4.9 The vehicle parking provision would be agreed with GC, based on the car parking guidance that is summarised in Table 4.1.

Table 4.1 Gateshead Council Car Parking Guidance

Space Type	Minimum allocated	Maximum allocated
Residents	1 per dwelling	2 per dwellings
Visitors	1 per 4 dwellings	1 per 3 dwellings

4.10 In accordance with GC it should also be noted that garages with a minimum internal space of 6m x 3m (7m by 3m if also considered cycle parking) are to be counted as 0.5 spaces.

4.11 It is also proposed that layby visitor parking bays will be 6m x 2m and have 2m x 2m chamfers. Single driveways will be 6m long and double driveways will be 11m long and have a 2m zone marked with a pin kerb and change of surface to encourage parking behind the visibility splays for the adjacent properties.

4.12 The parking standards suggest that the minimum number of parking spaces provided within the development should be 292 resident spaces and 73 visitor spaces. The maximum number of spaces that should be provided is 584 resident spaces and 98 visitor spaces.

4.13 In terms of parking provision, the proposed development, will include:

- 464 allocated resident spaces;
- 108 garage spaces (equivalent to 54 spaces), and;
- 79 visitor parking bays (spread evenly throughout the site).

4.14 As can be seen, the proposed development overprovides on the minimum number of residential spaces required. However, even when including garages, the total number of parking spaces provided is a total of 518, which is still below the maximum number of allocated resident spaces that are recommended within a development of this type. Additionally, the 79 visitor spaces is slightly over the minimum number that should be provided and is considered adequate for the development proposals.

4.15 As such, the proposed level of internal car parking to be provided is considered to be a suitable balance between ensuring sufficient parking opportunities, whilst also not delivering a living environment that is dominated by parked vehicles.

4.16 In addition to the proposed parking provision, each dwelling will be equipped with an electric vehicle charging point to facilitate the use of electric vehicles.

4.17 There will also be secure cycle facilities provided within the curtilage of each dwelling plot. Where no garage is provided for a property, it is proposed that a secure shed with a Sheffield bike stand will be provided. This enables the proposed development to meet the requirements of the GC cycle parking guidance.

4.18 Comments from the council also requested a parking survey be undertaken on George Street and Mitchell Street to find how many cars would normally park on each side of these roads. The surveys were

undertaken on a Thursday and Saturday in June during the evening, at 19:00, as this is when it is assumed most people would be at home resulting in a larger number of vehicles being parked than any other time during the day. The results of the parking survey are included as Appendix 3.

- 4.19 The survey concluded that at most, there were 3 vehicles parked on either side of George Street. For Mitchell Street, the count found that at most there would be 32 vehicles parked on either side of Mitchell Street, with a maximum of 24 counted on the southern side.
- 4.20 As the proposed development would have a number of houses facing onto George Street and Mitchell Street, this would result in the loss of the current on-street parking on the western side of George Street and the northern side Mitchell street. To overcome this, it is proposed that formal parallel parking bays are painted on both George Street and Mitchell Street, as shown in Figure 10.

Figure 10 Parking Arrangements – George Street & Mitchell Street

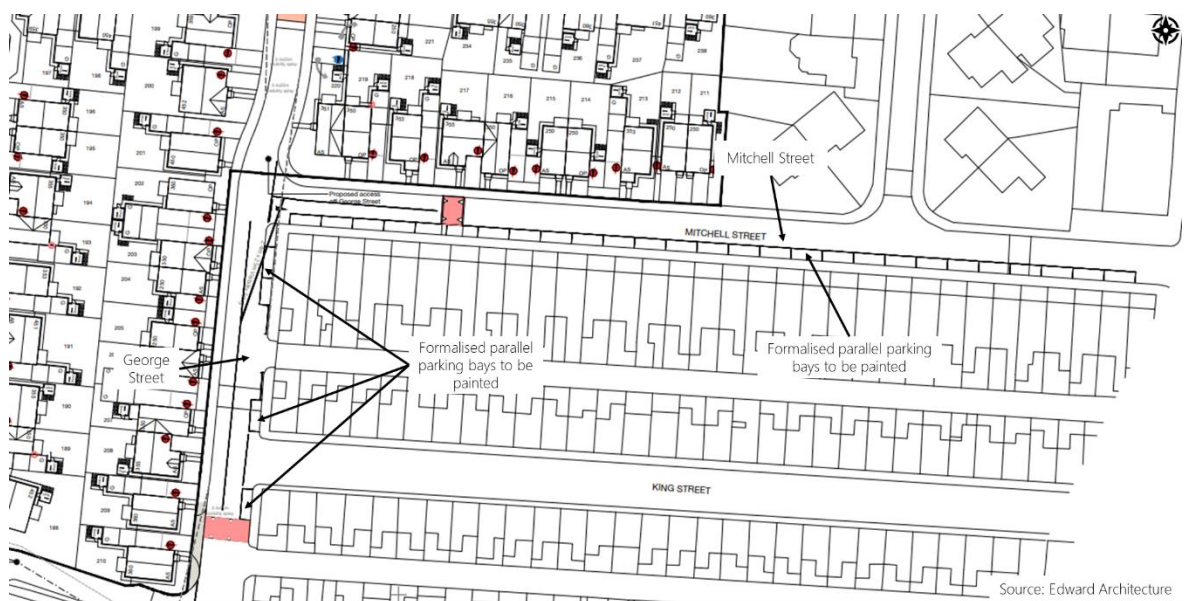

- 4.21 As shown, it is proposed that 4 spaces are formally outlined on the eastern side of George Street, this is considered adequate based on the parking surveys the were carried out. The proposals also provide an additional space to the maximum number of parked cars counted.
- 4.22 It is also shown that 27 spaces will be provided on the southern side of Mitchell Street which will more than accommodate the numbers of parked cars found on the southern side of the street. It is of note that at most 32 spaces would be needed and a provision of 27 formal spaces results in a shortfall of 5 spaces. But it should also be noted that there is also the opportunity for parking on the northern side of Mitchell street between the eastern extent of the development and Ravensworth Road, which could easily accommodate parking for upwards of five vehicles.
- 4.23 Overall, the level of proposed internal and external parking is considered suitable for the proposed development and will provide formalised parking spaces on George Street and Mitchell Street.

Pedestrian & Cycle Infrastructure

- 4.24 The proposed layout of the development reflects the principles of MfS by creating safe routes which ultimately promote the interests of the residents as pedestrians and cyclists.
- 4.25 The development layout incorporates multiple access points to aid the most direct walking routes to bus stops and the surrounding amenities. These include via the vehicular accesses to the north and south and via two footway links to Ravensworth Road on the eastern boundary of the site.
- 4.26 Overall, the development is considered to offer good access arrangements for pedestrians and cyclists and links through the estate and to the wider local highway network.

Emergency, Servicing & Refuse Vehicle Access

- 4.27 The proposed development will include suitable facilities to allow emergency, delivery and refuse vehicles to enter and leave in a forward gear via the two accesses proposed. The proposal also provides turning heads to facilitate access and turning facilities to parts of the development.
- 4.28 The routes have been sized to allow an 11.2m refuse vehicle to manoeuvre throughout the site, and swept path analysis confirm that all turning heads are of a suitable size to allow this to occur. The swept path analysis is included as Appendix 4.

5. Accessibility by Sustainable Transport

Proximity to Local Amenities

- 5.1 The purpose of this section of the TA is to review the proposed development in terms of its access via sustainable transport, by taking into account the proposed access strategy set out in the previous section.
- 5.2 The site is located to the west of Birtley in an existing residential area and has access to a wide range of amenities, facilities and employment opportunities available for prospective residents. The main facilities and amenities lie within Birtley on the A167 to the east of the site and the main employment opportunities lie further east of the site along Portobello Road.
- 5.3 A walking distance of 2km is generally considered to be reasonable for day-to-day trips including commuting and school journeys and 1.2km is generally considered reasonable for other journey purposes. Amenities within a 2km travel distance from the centre of the site are shown on Figure 11.

Figure 11 Local Amenities

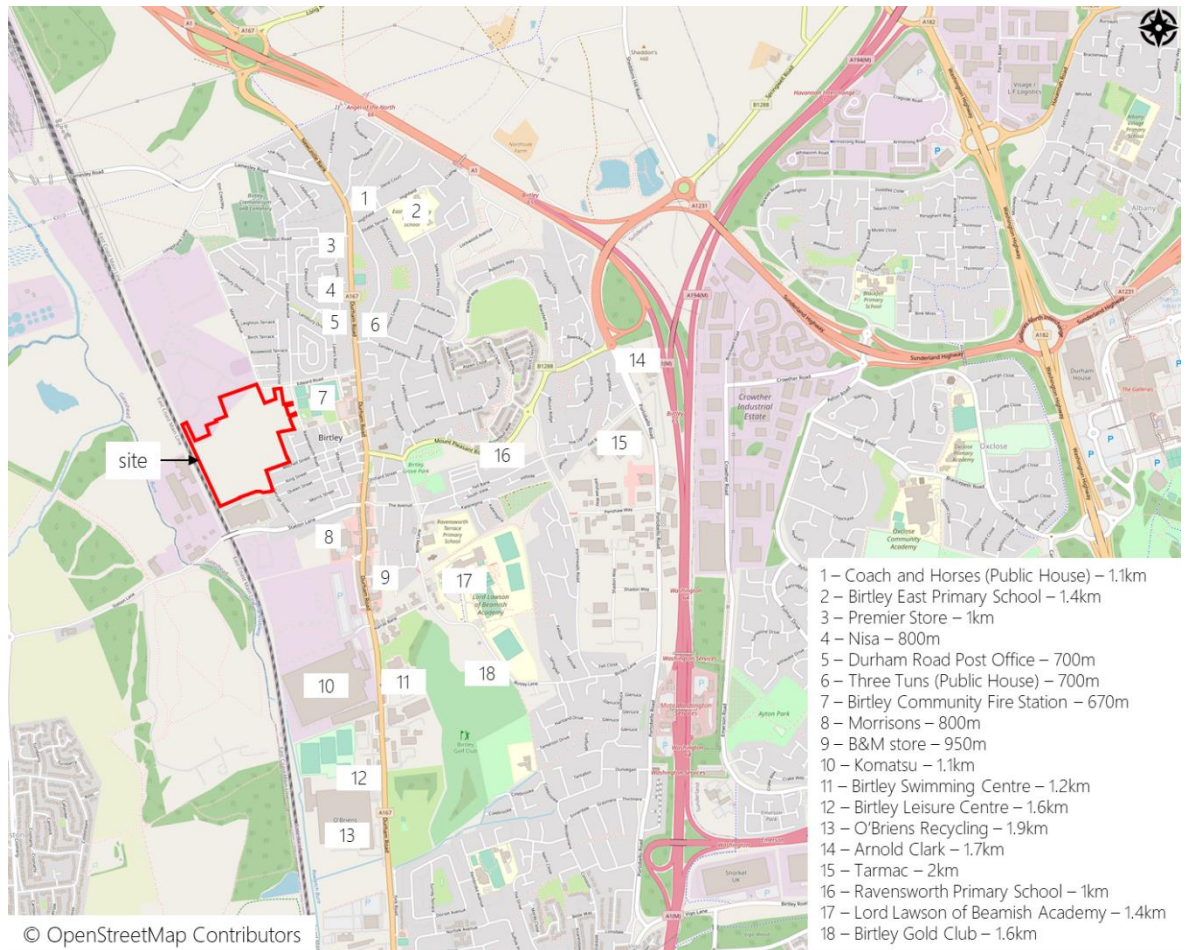

- 5.4 Figure 10 demonstrates that the site is within walking distance of a wide range of local amenities including primary and secondary schools, supermarkets, high street shops, community facilities, playing fields and children’s play areas, leisure facilities and employment opportunities.

- 5.5 Further facilities on the A167 in Birtley include:
- Several bus stops on both sides of the carriageway;
 - Pubs, restaurants and takeaways;
 - Police Station;
 - Pharmacist;
 - Church; and
 - Petrol station.
- 5.6 In addition to the 2km walking distance, 5km is normally considered a reasonable distance for cyclists to travel to work, or for shopping / leisure purposes.
- 5.7 As previously noted, there is an excellent range of amenities within 2km of the site, and therefore a 5km distance would only serve to extend this number of amenities further, including providing access to the wider Birtley town centre, southern Gateshead and Washington town centre areas, along with the entirety of the Team Valley Trading Estate.
- 5.8 Overall, there is a good range of amenities within Birtley within walking distance of the site and an exceptional range within a 5km cycle distance.

Pedestrian & Cycle Accessibility

- 5.9 In addition to the physical pedestrian and cycle facilities surrounding the site discussed in this section, it is also worth noting that the proposed development intends to implement a Travel Plan (TP) to encourage sustainable transport use by residents. The key measures of the measures that will be implemented are discussed further in Section 6.

Pedestrians

- 5.10 The proposed internal development layout provides direct walking routes to the nearest bus stops and the surrounding amenities by providing pedestrian access points to the north, east and south of the site.
- 5.11 Beyond the site boundary, there are footways throughout the existing residential areas to the east, on Station Lane and on the A167. There are dropped kerb crossing points, traffic calming measures and 20mph speed limits imposed to facilitate a safe pedestrian environment.
- 5.12 There is an extensive local network of segregated (traffic free) footways and public footpaths that are located within the surrounding estates. These networks combine with the highway network to provide numerous links between the site and the surrounding area, including to Birtley town centre.
- 5.13 The local network of roads and paths is shown in Figure 12, for information.

Figure 12 Local Roads and Paths

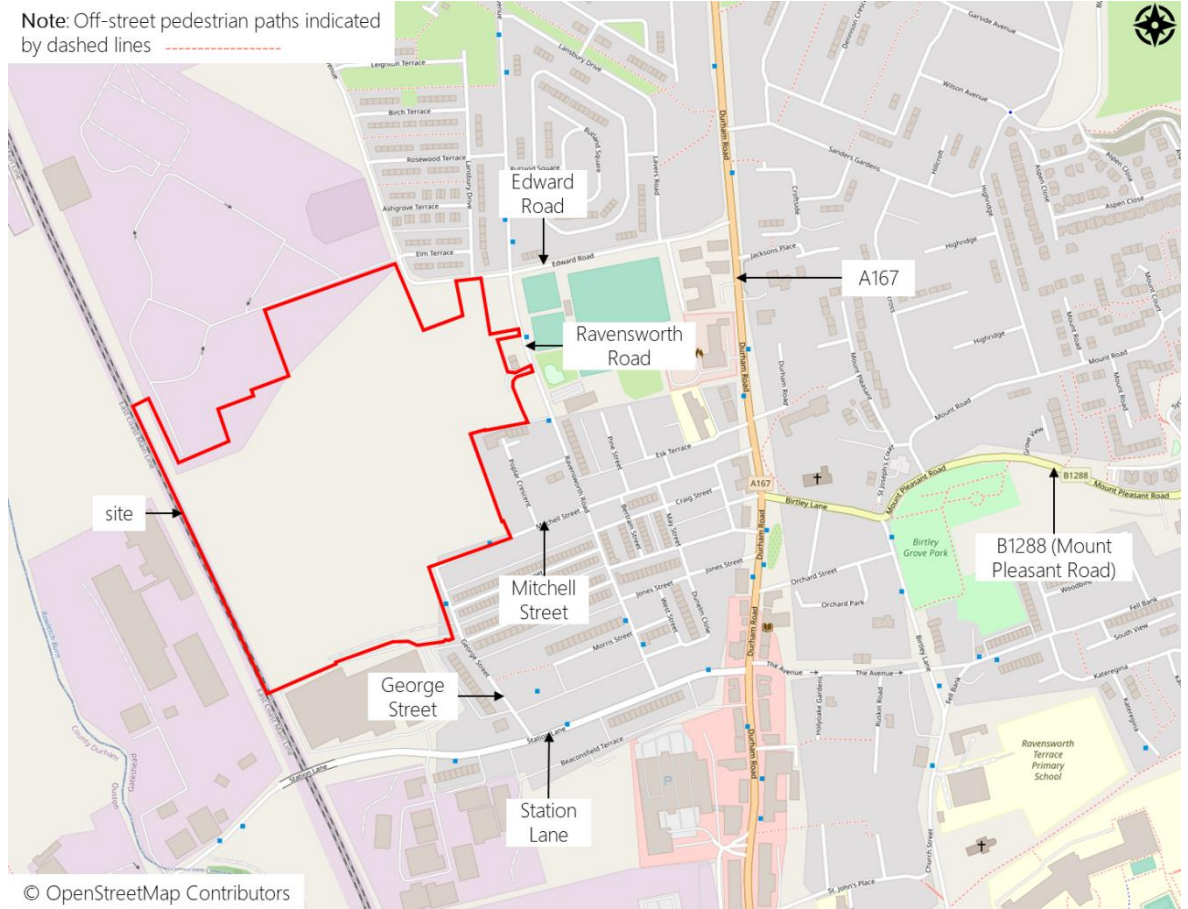

- 5.14 Overall, the network of pedestrian paths within the vicinity of the site provides good links to the surrounding amenities and facilities, which are generally within walking distance.

Cycling

- 5.15 The GC cycle map shows that, to the east of the site, the A167 through Birtley forms part of the National Cycle Network (NCN) which locally follows a route south towards Chester-Le-Street and north towards Gateshead and Newcastle. The route within Birtley generally comprises of on-carriageway cycle lanes.
- 5.16 Using the NCN, Chester-Le-Street and the southern areas of Gateshead are within a 5km cycling distance of the site. The cycle map also shows that Station Lane could be used as a road link to the NCN on the A167.
- 5.17 To the east of the site, there is a traffic-free stretch of cycle route which links to a signposted on-road cycle route which heads north towards the A1. This route then crosses the A1 and connects to routes into South Tyneside and the extensive cycle network within Washington.
- 5.18 Key employment areas within a 5km cycling distance are also accessible through a mix of on and off-road cycle routes, including the industrial estate at Portobello Road and the southeast of the Team Valley Trading Estate to the northwest of the site.

5.19 An extract of the GC cycle map in included as Figure 13, for information.

Figure 13 Extract of Gateshead Cycle Map

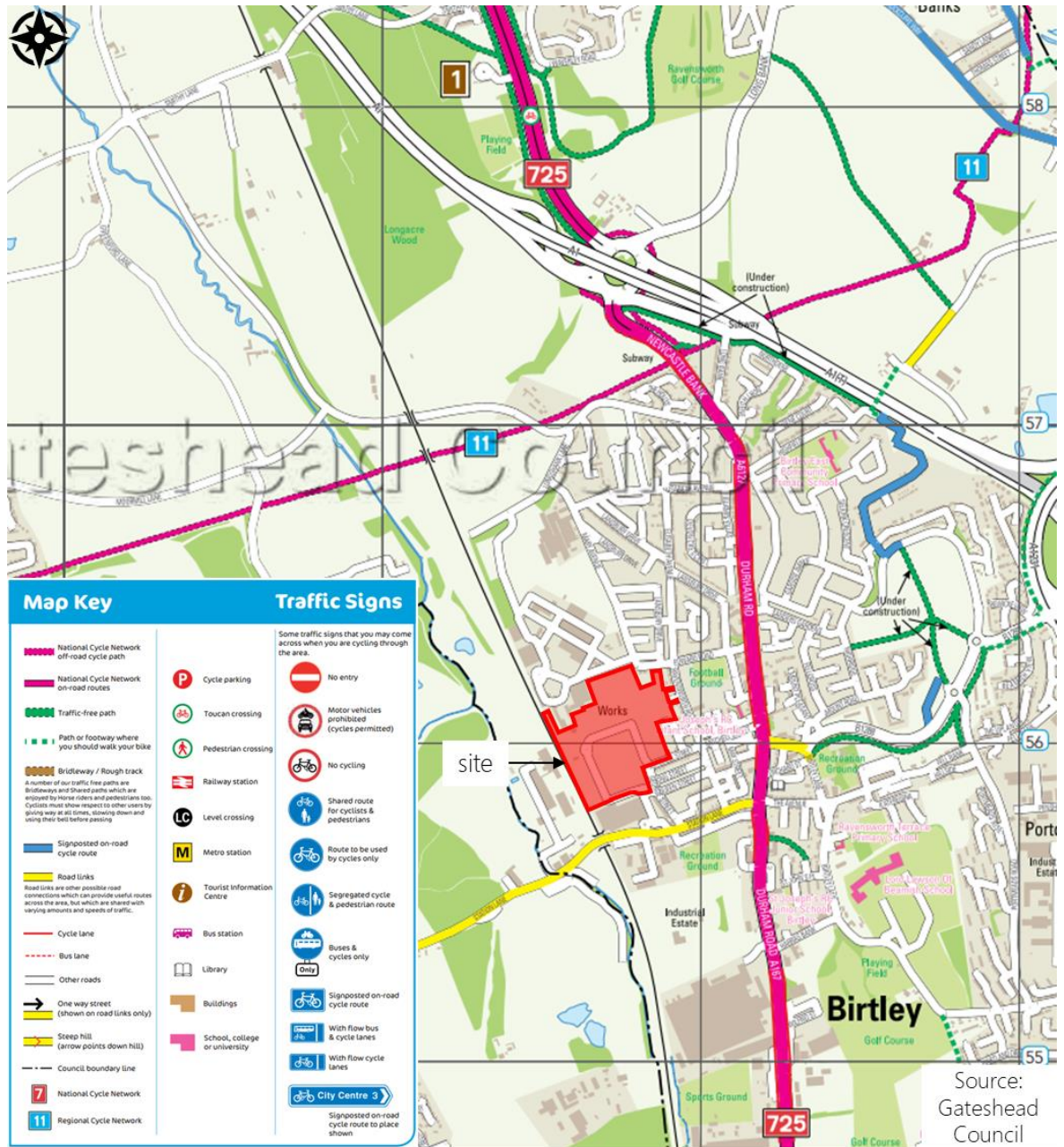

Source: Gateshead Council

5.20 In addition to the defined cycle routes, it would be considered reasonable to cycle on the local residential road network and more experienced / confident cyclists can use the main carriageway of the surrounding distributor roads to reach their destinations.

5.21 Each dwelling will be provided with a secure cycle storage facility to encourage cycling trips for varying journey purposes.

5.22 In summary, the site is very well located for cycling routes which provide access to a wide range of local amenities and employment opportunities within a reasonable cycling distance.

Public Transport Connections

5.23 Bus stops in the vicinity of the site are shown in Figure 14.

Figure 14 Local Bus Stops

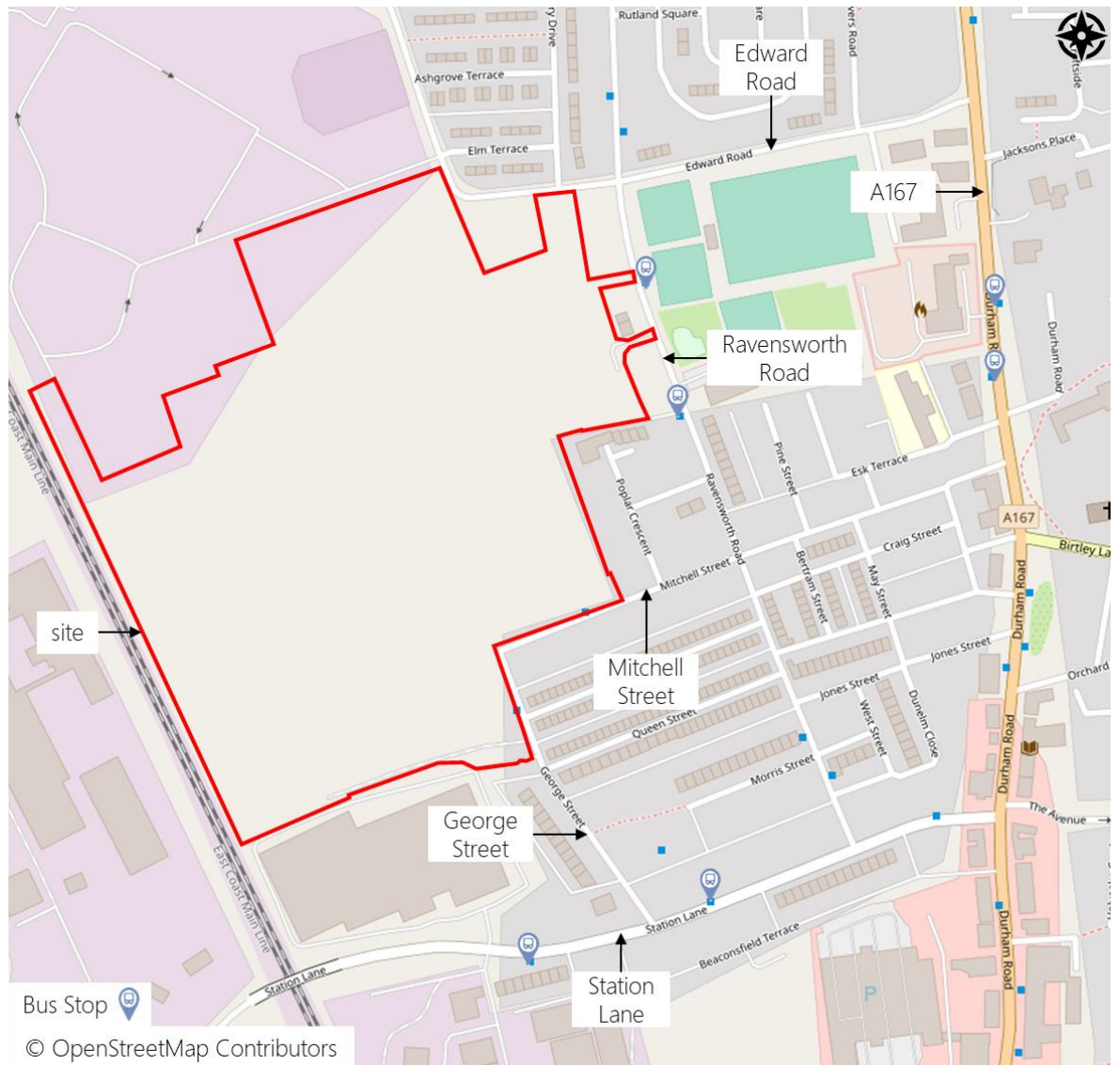

5.24 The nearest bus stops to the site are located on Ravensworth Road, Station Lane and the A167. The bus stops on Ravensworth Road are within 240m walking distance of the centre of the site. The bus stops on Ravensworth Road are flagged and have a timetable. The northbound bus stop also has a shelter.

5.25 The bus stops on Station Lane are within 370m walking distance from the centre of the site. These bus stops are flagged and have timetables.

5.26 On the A167 the bus stops are within 500m walking distance from the centre of the site. The stops on this route are on-road, have flags, timetables and have a shelter.

5.27 The services that operate from these bus stops are summarised in Table 5.1.

Table 5.1 Local Bus Services

Service	Route	Service Frequency		
		Mon-Fri	Saturday	Sunday
Bus Stop Location – Ravensworth Road				
82	Queen Elizabeth Hospital – Washington Galleries	1 service per hour (07:13 – 18:13)	1 service per hour (08:13 – 18:13)	No Service
Bus Stop Location – Station Lane				
28	Newcastle City Centre – Chester-Le-Street	1 service per hour (08:26-18:44)	1 service per hour (08:34-18:34)	1 service per hour (09:46-18:46)
29	Newcastle City Centre – Chester-Le-Street	1 service per hour (07:51-18:14)	1 service per hour (08:04-18:04)	No Service
28B	Newcastle City Centre – Chester-Le-Street	1 service per hour (19:11-23:01)	1 service per hour (18:56-23:01)	No Service
Bus Stop Location – A167 (Durham Road)				
21	Chester-Le-Street – Newcastle City Centre	Up to 8 services per hour (04:48-23:51)	Up to 8 services per hour (04:48-23:51)	Up to 6 services per hour (04:48-23:51)
28	Newcastle City Centre – Chester-Le-Street	1 service per hour (08:25-18:43)	1 service per hour (08:33-18:33)	1 service per hour (09:45-18:45)
29	Newcastle City Centre – Chester-Le-Street	1 service per hour (07:50-18:13)	1 service per hour (08:03-18:03)	No Service
28B	Newcastle City Centre – Chester-Le-Street	1 service per hour (19:10-23:00)	1 service per hour (18:55-23:00)	No Service
882	Mount Pleasant – Cardinal Hume Catholic School	1 AM service, 1 PM Service	No Service	No Service
937	Durham City Centre – Metrocentre	1 service per hour (06:37-07:37)	No Service	No Service
N21	Chester-Le-Street – Newcastle City Centre	1 service per hour (00:51-03:51)	1 service per hour (00:51-03:51)	1 service per hour (00:51-03:51)
TB14	Kibblesworth – Birtley – Barley Mow	1 AM service, 1 PM Service	No Service	No Service

5.28 Overall, there are good local bus services within a 500m walk of the site that provide links to a range of surrounding conurbations, retail sites, employment areas and schools.

Accessibility Summary

5.29 In summary, the development is within reasonable walking and cycling distance of an excellent range of amenities and employment opportunities that can be reached via good routes. There are also good bus services extending into the surrounding area. Overall, the site is very accessible by sustainable modes.

6. Accessibility Audit Review

6.1 The previous outline permission included an accessibility audit which ensured that all links from the site to local amenities were fit for purpose, where this was not the case, improvements were suggested. Following comments from GC, an updated audit has been requested relating to this proposed development. As such, this section discusses the outcomes of the previous audit and provides an updated version to ensure all accesses are of a suitable standard.

Initial Accessibility Audit (2011)

6.2 A survey was conducted in August 2011 to review the main links on the highway network to a number of amenities and facilities in the vicinity of the site. The locations considered within the audit are shown in Figure 15.

Figure 15 Surveyed Locations

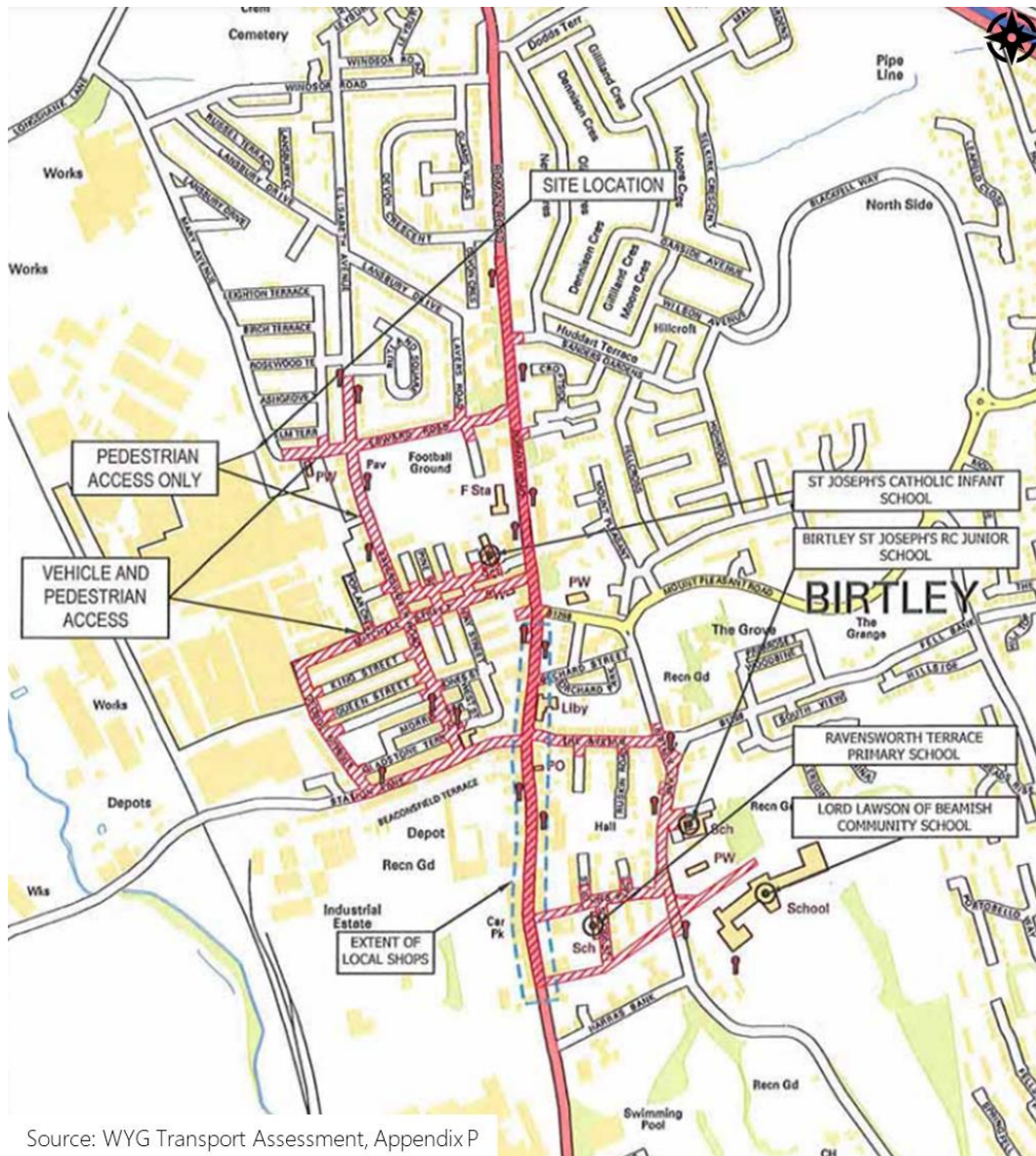

6.3 The local highway links considered for the audit included, but were not limited to the following:

- Mary Avenue;
- Edward Road;
- Elisabeth Avenue;
- Durham Road, north of the junction with Station Lane and The Avenue;
- Ravensworth Road;
- Mitchell Street;
- Unnamed road to St Joseph’s Catholic Infant School (Esk Terrace);
- Station Lane;
- Birtley Lane, from its junction with The Avenue, to St John’s Place (Church Street);
- Durham Road, south of its junction with Station Lane and The Avenue, and;
- St John’s Place.

6.4 The general comments of the audit suggested that many of the junctions and crossings were adequate for pedestrians and cyclists, with dropped kerb facilities, tactile paving and refuge islands present on primary routes in Birtley.

6.5 It was also considered that general footway conditions were acceptable, with some steeper gradients which could present issues for users with impaired mobilities.

6.6 In total there were nine issues identified within the initial audit that could impact the accessibility of the site by sustainable modes of transport. The issues found are outlined in Table 6.1.

Table 6.1 2011 Audit – Identified Issues

Reference	Location	Issue Observed
1	Edward Road / Ravensworth Road	Street name sign in the middle of the footway
2	Edward Road / Lavers Road	No dropped kerbs on the northern side
3	Edward Road / Access to Fire Station	No dropped kerbs
4	Ravensworth Road / Esk Terrace	No dropped kerbs
5	Mitchell Street / Ravensworth Road	No dropped kerbs
6	Ravensworth Road / Queen Street	No dropped kerbs on east side
7	Mitchell Street	No dropped kerbs
8	Birtley Lane / Access to Ravensworth Terrace Primary School	No dropped kerbs on east side
9	St John’s Place / St Joseph’s RC Junior School	No dropped kerbs on school street

6.7 The locations of each of these issue is indicated in Figure 16.

Figure 16 Identified Issue Location

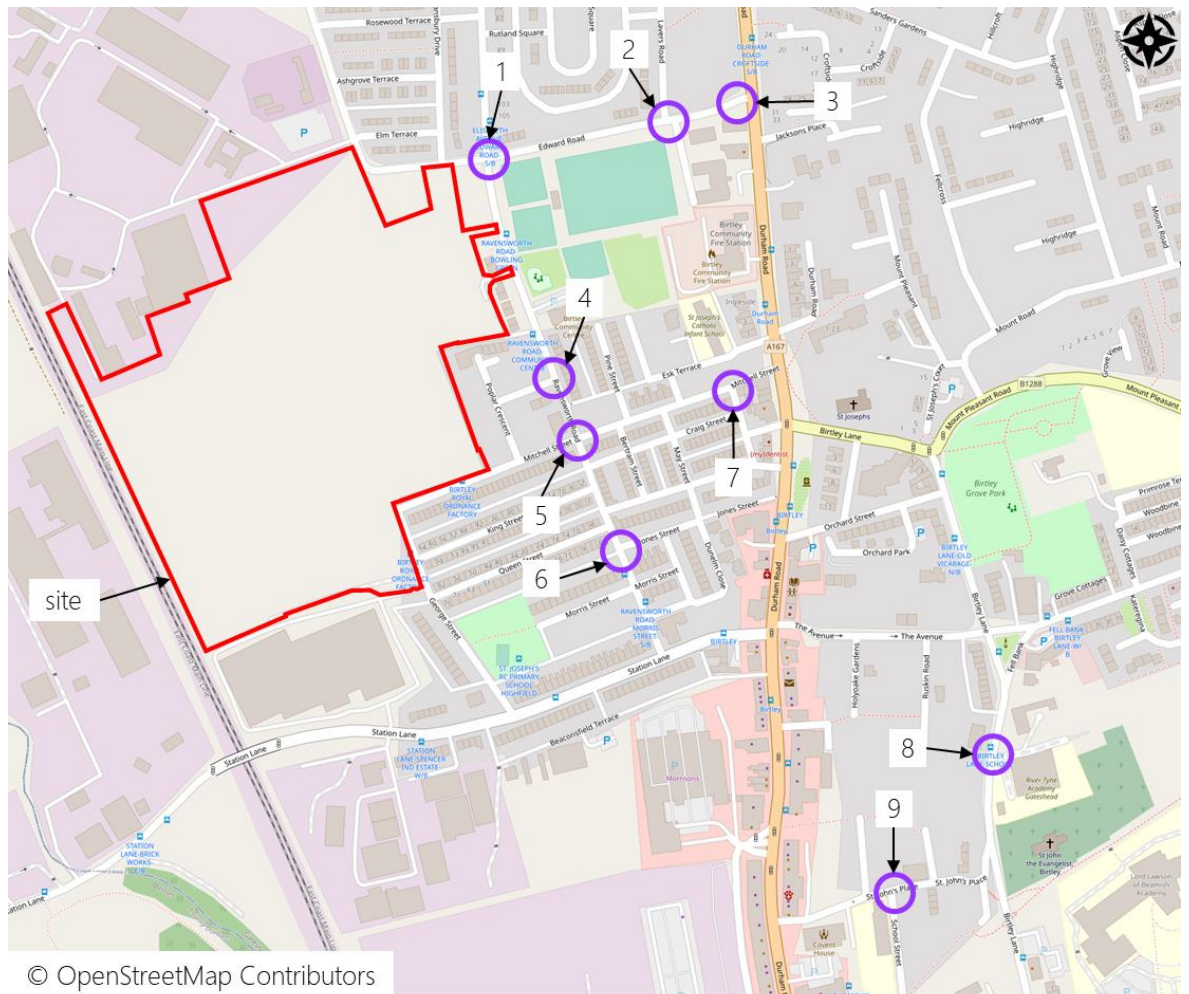

- 6.8 It was also concluded within the audit that the issues highlighted do not completely restrict access to local amenities and facilities as there are other alternative routes available.
- 6.9 Overall, the initial audit concluded that remedial works would be needed to overcome the issues observed and a contribution was proposed to cover the costs of the works required.

Updated Accessibility Audit (2022)

- 6.10 A review of this audit was conducted in June 2022, following the same routes and amenities. It is of note that Ravensworth Terrace Primary School has since been relocated further north in Birtley and is now situated on the B1288 (Mount Pleasant Road). As such, an audit of the B1288 from Birtley Lane to the primary school, has also been conducted when revising the audit.
- 6.11 The revised audit followed the same search area as previously used, with the inclusion of part of the B1288 (Mount Pleasant Road), no additional issues to the previous audit were found.
- 6.12 Table 6.2 provides comments and responses regarding the current state of the nine initial issues that had been found in the 2011 audit.

Table 6.2 Responses and Comments to Identified Issues

Issue Reference	Response/Comment
1	No obvious signs observed in the middle of the footway, no additional improvement work considered necessary
2	There are no dropped kerbs on the northern side of the carriageway, improvement works would be beneficial
3	Dropped kerbs are now visible, no additional improvement work considered necessary
4	There are no dropped kerbs at this junction, improvement works would be beneficial
5	There are no dropped kerbs at this junction, improvement works would be beneficial
6	There are no dropped kerbs at this junction, improvement works would be beneficial
7	There are no dropped kerbs here, improvement works would be beneficial
8	There are still no dropped kerbs on the east side, but mitigation works are no longer considered necessary as the primary school has since been relocated
9	There are no dropped kerbs at this junction, improvement works would be beneficial

6.13 Overall, there were no new issues observed in the revised audit. Two of the original issues were found to have been resolved since the original audit. One of the issues was considered no longer necessary as Ravensworth primary school has since relocated and the routes to the new school are considered to be adequate for use by pedestrians and cyclists, with dropped kerb crossings, speed calming measures and zebra crossings to facilitate safe movements for all users.

6.14 Given the nature of the issues identified, it is still considered that the remaining six issues would require remedial improvement works, without causing significant changes to the character of the local highway network.

6.15 Therefore, a contribution (to be agreed with GC) would be provided by the developer to cover the construction costs associated with the six identified issues that should be resolved to facilitate safe routes to the large number of amenities and facilities within Birtley.

7. Travel Plan

Strategy Overview

- 7.1 A Travel Plan (TP) is designed to encourage residents to travel sustainably and consider their transport options when travelling to and from the development, to lower the impact of private vehicles on the local highway network.
- 7.2 In accordance with policy objectives at a local and national level, the purpose of a TP is to identify a strategy to promote travel by public transport, walking and cycling to reduce the reliance on the use of the private car for all trip purposes. This section constitutes the TP for this development proposal.
- 7.3 The TP will continue to be monitored, developed and improved throughout the development's life, from before first occupation to when the final dwelling has been occupied. Updates to the TP will be submitted to GC to formally agree the initiatives therein, and it is anticipated that this monitoring and review process will form part of an appropriate condition on any planning approval.

Aim

- 7.4 The overall aim of the TP is to reduce reliance on the use of the private car to minimise the number of single occupancy vehicle trips that the development will produce.

Objectives

- 7.5 In order to achieve the overall aim of the TP, the following objectives are proposed:
- To promote walking and cycling as an alternative mode of transport to the private car, and to also encourage a healthier lifestyle;
 - To encourage the use of public transport as an alternative more to the private car;
 - To support car sharing schemes to minimise single occupancy private car journeys, and;
 - To provide ongoing promotion of the TP aim and strategies among residents.

Sustainable Transport Infrastructure

- 7.6 As previously noted, the development has excellent links for access by sustainable modes of transport. The objectives of the TP are supported by the internal layout of the development, which includes safe and convenient pedestrian and cycle links that connect to the surrounding sustainable transport network.
- 7.7 The objectives are further supported by the provision of secure cycle storage at each dwelling.
- 7.8 In addition to this, each property will have broadband connection to facilitate home working, internet shopping and internet banking, thus minimising the need to travel.

Travel Plan Delivery Strategy

- 7.9 This section of the TP outlines the initial strategies for implementing and managing the TP, subject to discussions with GC to agree the overall measures set out within the TP.

Travel Plan Coordinator

- 7.10 A Travel Plan Coordinator (TPC) will be appointed by the developer and their contact details will be provided to GC prior to occupation of the first unit. During the initial phases of the development, the TPC could be a member of the Developer's team, who has regular contact with prospective/new residents.
- 7.11 The TPC will be responsible for the implementation, communication, monitoring and management of the overall aim and objectives defined within the TP, and will:
- Oversee the implementation and improvements of the TP;
 - Raise awareness of the TP by implementing and promoting marketing campaigns;
 - Organise necessary surveys and data collection exercises to develop and review the TP;
 - Act as the point of liaison with residents and external organisations;
 - Coordinate the monitoring of the TP, including setting targets and review dates;
 - Provide additional communication, support and deal with any transport related queries, and;
 - Control the budget for the TP to ensure its effective and efficient use.
- 7.12 The TPC will ensure that the TP is implemented and managed over a period that is still to be confirmed. The TPC will ensure that all measures are implemented and promoted and provide all necessary monitoring information to GC.

Communication

- 7.13 The success of a TP relies on support from the residents. As such, the TPC will be fully aware of the initiatives set out in the TP and will be the first point of contact for any transport related issues or queries.
- 7.14 The wider sales team will also be made aware of the initiatives set out in the TP and how best to inform prospective residents about the transport measures in place. Prior to the purchase of a property, potential residents will be alerted to the TP for the site through marketing materials.
- 7.15 Alongside this, there will also be promotional material in the form of websites, flyers and surveys to further highlight the TP to residents. This will encourage residents to contact the TPC for any transport related issues and the TPC will then liaise with the appropriate bodies.
- 7.16 Promotional material will also be used to ensure residents are aware of any changes or improvements to the TP initiatives through various forms including flyers, emails and websites.
- 7.17 A successful TP depends on the development and implementation of effective strategies. To increase awareness of the TP, residents will be given information on sustainable transport in their Welcome Packs, as well as flyers and emails to inform them of any updates to the TP strategies.

Scheme Administration

- 7.18 It will be the responsibility of the TPC and the wider sales team to ensure the maintenance of data, administration, consultation, promotion and running of the necessary systems. These duties will include making regular updates to the TP. Due to GDPR guidance, any correspondence of data collated for the purposes of the TP will be maintained by the TPC and sales team only.

Monitoring and Review

- 7.19 A programme of monitoring and review of the TP will be implemented to generate information by which the success of the TP will be evaluated. This will be the TPCs responsibility, in consultation with GC, to ensure that the aim of reducing the number of single occupancy vehicle trips in favour of more sustainable transport is achieved.

Funding

- 7.20 The Developer will allocate a budget to cover the implementation, monitoring and review of the TP. The level of funding will be agreed with GC and will be sufficient to deliver the TP aim and objectives.

Targets & Surveys

- 7.21 The TP is designed to increase awareness of the use of sustainable transport modes. The monitoring and review programmes will allow the TPs progress to be assessed, but it should be assessed against specific targets.
- 7.22 The TP is designed to increase awareness of sustainable transport options and to encourage their use. The monitoring and review programmes will allow the progress of the TP to be checked, but it must be assessed against specific targets.
- 7.23 Targets guide the TP and provide a measurable goal, so it is important that site-specific targets are 'SMART' (Specific, Measurable, Achievable, Realistic, Time-bound) so that the outcomes can be quantified so the achievements of the TP can be assessed.
- 7.24 The success of a TP is generally indicated by a change in the modal split of trips to and from the development, with the result of a reduction in single occupancy private vehicle journeys.
- 7.25 It is proposed that as a starting point, the targets for this TP are based on those set out in the Birtley Northside TP which operates for an area of Birtley to the north east of the site, towards the A1. These are shown in Table 7.1 and are based on a modal split of traffic derived from 2011 Census data for the MSOA 'Gateshead 025'.

Table 7.1 Initial Travel Plan Targets

Mode	Initial Level	Target Level	Change
Sustainable Transport*	27%	28%	+1%
Car - Driver	64%	62%	-2%
Car - Passenger	8%	9%	+1%
Other Methods**	1%	1%	0%

*Including underground/Metro train, bus, bicycle and on foot categories
 **Including taxi, motorcycle and other categories

- 7.26 The targets are considered to be robust due to the proposed development being more favourably located than the Birtley Northside development. An increase of 1% of both sustainable transport uses and car passenger journeys alongside a reduction in 2% of single occupancy private car journeys is therefore considered a reasonable initial basis for setting targets during the initial phase of the development.
- 7.27 It is envisaged that regular surveys will be undertaken to check the progress against the aim, objectives and targets set out in the TP. The methodology and timescales for any surveys will be agreed with GC.
- 7.28 It is anticipated that the initial targets set out in Table 6.1 will be adjusted following the first resident travel survey, as site specific travel information will then be available.
- 7.29 Overall, the key outcome of the TP is to reduce the number of single occupancy private vehicle trips, in favour of more sustainable modes of transport, once the site is fully occupied.

Travel Plan Measures

- 7.30 The key measures of the TP are as follows:
- A TPC will be identified by the developer as a first point of contact for any transport related issue.
 - The sales team be fully aware of the TP and inform prospective residents prior to the purchase of a property.
 - During the design and construction phases, roads and footways will be constructed to serve each home and create links for sustainable transport modes.
 - Each dwelling will have secure cycle storage within the bounds of each plot.
 - Each dwelling will have broadband connection to facilitate home working and reduce the need to travel for shopping purposes.
 - Each resident will be issued with a Welcome Pack that sets out information on local amenities, walking/cycling routes, public transport services, promotional events, car clubs and car share schemes.
 - The Welcome Pack will also include details of incentives that are available including how to claim a free bus 'ticket' entitling each household to a week's free public transport use and a free £100 voucher for each household to be put towards the cost of a new cycle / cycle accessories.
 - The TPC and sales team will provide ongoing and updated information to residents through the initial phases of occupation, including details of local facilities and sustainable transport routes.
- 7.31 The TPC will operate specific measures to encourage the use of sustainable transport modes and include:
- Promoting online car sharing and car club schemes (updated regularly);
 - Encouraging walking for commuting and leisure, including the promotion of events;
 - Promoting the use of public transport and distributing information on services, schedules and costs (updated regularly);
 - Undertaking an investigation into the surrounding area TPs, to form links for mutual benefits, and;
 - Encouraging cycling for commuting and leisure, including the promotion of events.

8. Trip Generation, Distribution and Assignment

Traffic Generation

- 8.1 As previously discussed, since the initial submission, there have been a number of minor layout changes leading to an overall reduction of 6 dwellings across the development (from 298 to 292). The initial trip generation, distribution and assignment exercise was based on a site of 298 dwellings, given the small reduction in units, the previous analysis is considered to be robust for a development of 292 dwellings. Therefore, the analysis based on 298 dwellings is deemed acceptable and robust, and has not been revised in light of the new layout.
- 8.2 TRICS (v7.8.2) had been used to estimate the potential multi-modal trips that will be generated at the development. In line with standard practice, surveys were excluded from the sample set for Greater London, Ireland and all offshore islands.
- 8.3 'Suburban Area' locations for 'Houses Privately Owned' were specified with Tuesday, Wednesday and Thursday used to give representative datasets. The parameters selected are considered reasonable to give an indication of the anticipated trip levels, based upon the context of the site.

Peak Hour Assessment

- 8.4 The peak travel periods identified within the TRICS outputs were 08:00-09:00 and 17:00-18:00. Predicted development trips were then derived from the TRICS trip rates based upon the initially proposed 298 dwellings. Table 8.1 sets out the predicted AM and PM peak hour trip rates for all modes of transport. Table 8.2 shows the predicted number of trips that would be generated, based on the resultant trip rates from TRICS. The full TRICS output data is included as Appendix 5.

Table 8.1 Mean Residential Trip Rates (per dwelling)

Mode	AM Peak Hour (08:00-09:00)			PM Peak Hours (17:00-18:00)		
	Arrivals	Departures	Total	Arrivals	Departures	Total
Total Vehicles	0.107	0.387	0.494	0.365	0.184	0.549
Cyclists	0.000	0.017	0.017	0.003	0.002	0.005
Pedestrians	0.049	0.165	0.214	0.055	0.045	0.100
Public Transport	0.002	0.054	0.056	0.033	0.006	0.039
Total People	0.172	0.853	1.025	0.659	0.330	0.989

Table 8.2 Trip Generation (per 298 dwellings)

Mode	AM Peak Hour (08:00-09:00)			PM Peak Hours (17:00-18:00)		
	Arrivals	Departures	Total	Arrivals	Departures	Total
Total Vehicles	32	115	147	109	55	164
Cyclists	0	5	5	1	1	1*
Pedestrians	15	49	64	16	13	30
Public Transport	1	16	17	10	2	12
Total People	51	254	305	196	98	295

*Rounding anomaly
Note that the individual modes do not add up to the 'Total People' figure as some modes are not shown, e.g. car passengers.

- 8.5 Using the proposed trip rates, the development is estimated to generate approximately 147 two-way vehicle movements in the AM peak hour and 164 two-way vehicle movements in the PM peak hour. The total people movements are shown to be 305 two-way trips in the AM peak and 295 two-way trips in the PM peak. Cyclists, pedestrians and public transport account for a combined total of 86 two-way movements in the AM peak and a combined total of 43 two-way trips in the PM peak.

Total Vehicle Movements

- 8.6 The total vehicle movements that will be generated to/from the site has been established using the 'Total Vehicle – Total Rates' as derived from the TRICS (v7.8.2) data attached as Appendix 5. The predicted 12 and 16-hour trips that will be generated from the site are shown in Table 8.3.

Table 8.3 12 and 16-Hour Trip Rates

Total Vehicles – Total Trip Rates (292 dwellings)	Arrivals	Departures	Total
12-hour vehicle trip rate (per dwelling)	2.228	2.345	4.573
12-hour vehicle trip generation	664	699	1363
16-hour vehicle trip generation*	764	804	1567

*12-hour trips multiplied by the E-Factor
^E-Factor = 1.15

- 8.7 The 16-hour trips were generated using the E-Factor as set in the COBA Manual Part 4 and are considered as a reasonable proxy for 24-hour trips.
- 8.8 The total two-way 12-hour vehicle trips as derived from the TRICS data is 1,363 two-way movements. The total (two-way) 16-hour trips predicted from the site is approximately 1,567 two-way flows. 1,567 two-way movements generated at the site is therefore considered reasonable for use as the total 24-hour flows to/from the site.
- 8.9 These figures have also been used in the associated noise / air quality assessment reports that accompany this planning application.

Traffic Generation Review

- 8.10 Comments from the council also raise concerns for the use of the proposed trip rates and not the trip rates used in TA for the initial outline application (DC/11/00546/OUT). As such, the trip rates used within the WYG TA have been reviewed.
- 8.11 The WYG TA uses trip rates that were obtained from TRICS in 2011, from surveys recorded between 2002 and 2010. As such, it is considered that these trip rates are outdated and would not be representative of current travel patterns.
- 8.12 The proposed trip rates used within this TA were obtained from TRICS in 2021 and make use of surveys undertaken between 2013 and 2020 (excluding any surveys undertaken during the Covid-19 pandemic). The new trip rates are considered to offer more appropriate and up-to-date trip rates based on current travel patterns.
- 8.13 Overall, it is considered that the updated trip rates used previously within this report are considered to be more appropriate than using out-of-date data. Therefore, the proposed trip rates are considered to be more representative of current travel patterns and will be used for further analysis purposes.

Traffic Distribution and Assignment

- 8.14 The total vehicle percentage distribution on the surrounding highway network, to/from the site has been worked out using the 2011 Census data with the usual place of residence being set to 'Gateshead 025'. The 2011 Census data is attached in Appendix 6 and shows each of the wards and districts that have been used to base the routes on. Table 8.4 shows the distribution of where residents are anticipated to work, by Local Authority district.

Table 8.4 Anticipated Place of Work

Local Authority	% Split
County Durham	12%
Gateshead	48%
Newcastle upon Tyne	16%
North Tyneside	4%
Northumberland	3%
South Tyneside	3%
Sunderland	13%

- 8.15 Based on the above analysis, vehicular trips to/ from each Local Authority district has been assigned onto the highway network using the Google Maps journey tool, simulating peak time trips, as shown in Table 8.5 and illustrated in full in Appendix 6.

Table 8.5 Trip Distribution and Assignment

Local Authority District	AM Peak Trips	PM Peak Trips	Route
County Durham	18	20	Split across various routes, primarily via A167 south
Gateshead	71	79	Split across various routes
Newcastle upon Tyne	24	26	Split across various routes, primarily via A1M north
North Tyneside	6	7	Split across various routes, primarily via A194M
Northumberland	4	5	Via A1M north
South Tyneside	4	5	Via A194M
Sunderland	19	21	Split across various routes, primarily via A1231
Total	147	164	

8.16 Overall, the routing exercise has shown that the site has the potential for two-way trips to/from a large range of conurbations in the local area. These trips are spread over a large number of routes and therefore the impact of the development will quickly disperse across the road network, as shown in Figure 17.

Figure 17 Trip Assignment

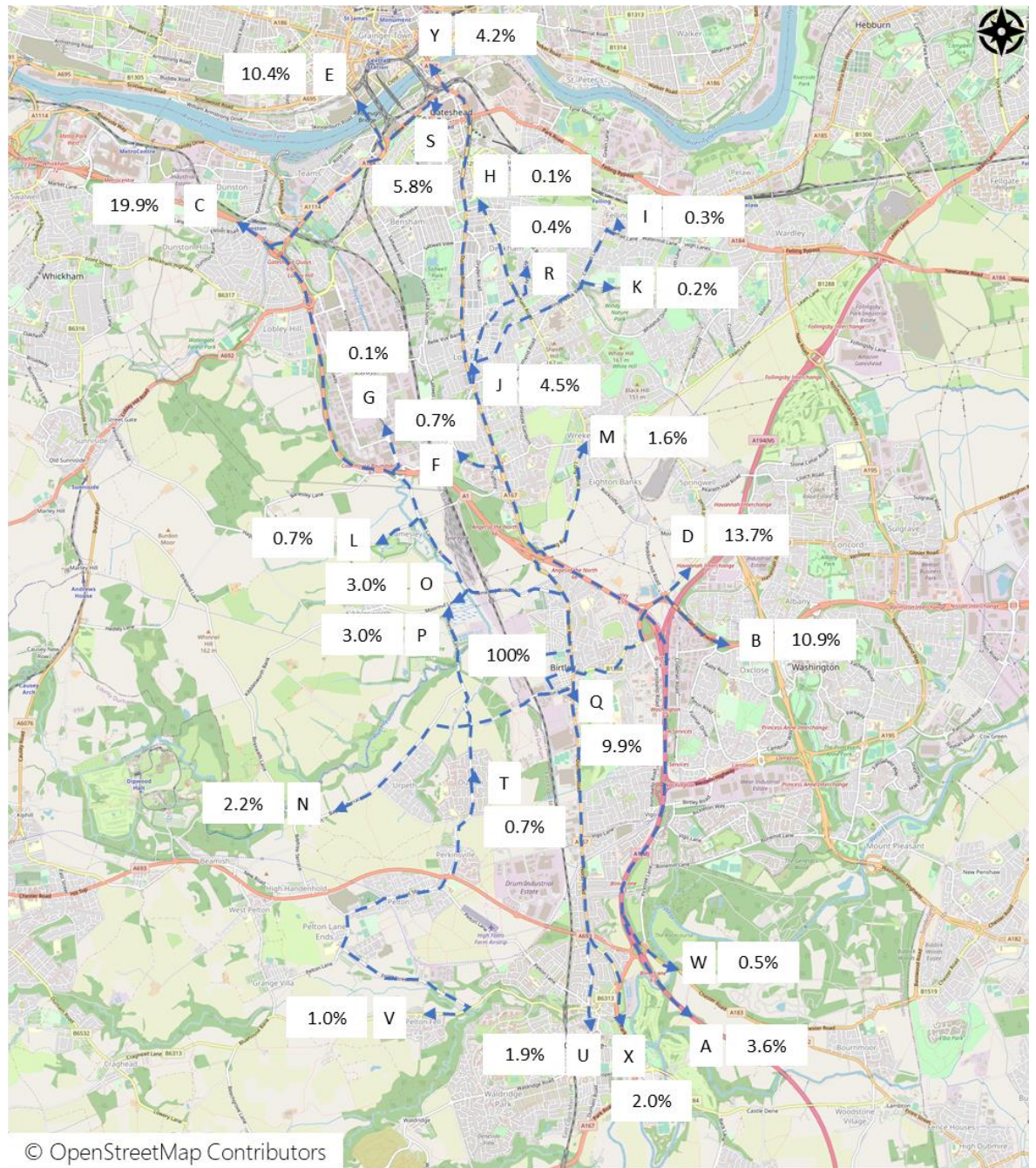

- 8.17 The Google Maps routing tool naturally routed all trips to the north of the A167, through the site and from the northern access onto Edward Road. Southern trips (including movements onto Birtley Lane) were equally routed from both accesses using Edward Road and George Street onto Station Lane. As such, for assessment purposes, the southern routes have been equally split at each access and the northern routes have been assumed to use the northern access only.
- 8.18 The assumed % assignments for traffic exiting and entering the site, via the roads in the immediate vicinity of the site are indicated in Figure 18.

Figure 18 Trip Assignment – % Leaving the Site

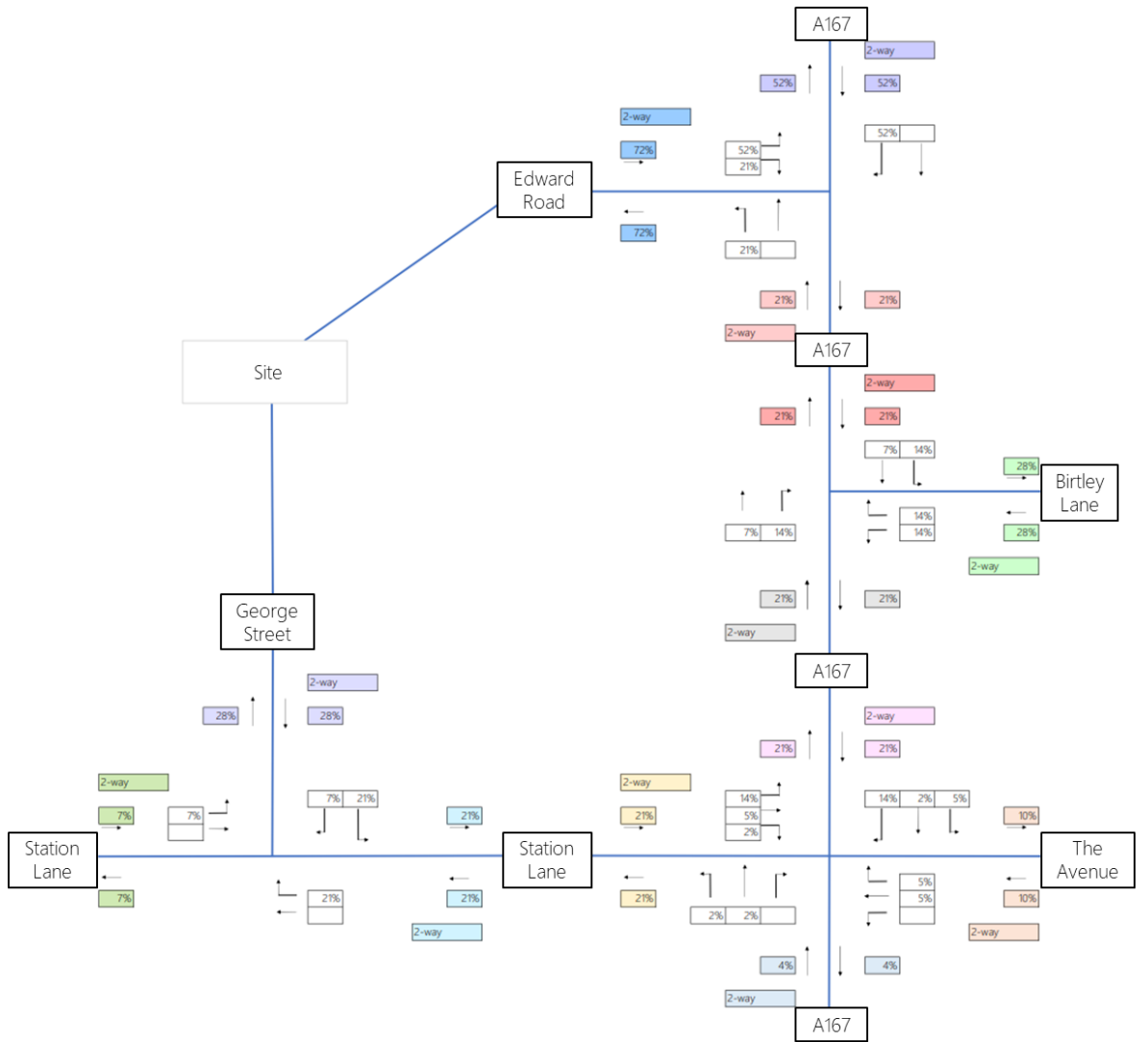

9. Traffic Impact Assessment & Mitigation

Impact Assessment

9.1 The previous version of this TA did not provide any impact assessments due to a lack of up-to-date traffic movements. It was originally agreed that an addendum document would be produced once the relevant surveys had been undertaken to obtain data on current traffic movements.

9.2 Given that the overall impact of traffic from the development is likely to be low, with private journeys discharging quickly across the local highway network, it was agreed with GC that five junctions within Birtley would need to be surveyed to form a basis for impact assessment purposes, including:

- A167 / Lamesley Road – priority junction;
- A167 / Edward Road – priority junction;
- A167 / Station Lane / The Avenue – signal controlled junction;
- A167 / Birtley Lane / Craig Street – signal controlled junction, and;
- George Street / Station Lane – priority junction.

9.3 It was also suggested that the A1 junction 67 should be surveyed, but NH offer no objections to the proposals, so it was agreed with GC that no survey/impact assessment was necessary.

9.4 This section of the report provides a revision to the original impact assessment, taking into account the modelling of the five junctions that have been surveyed. The remainder of this section sets out the methodology, modelling results and any mitigation measures proposed to facilitate the development.

Assessment Methodology

Baseline Traffic Figures

9.5 Baseline traffic flows have been derived from traffic survey data, collected by North East Traffic Data Collection Ltd (NETDC) on behalf of MTP, for the agreed junctions, as shown in Figure 19.

Figure 19 Modelled Junctions

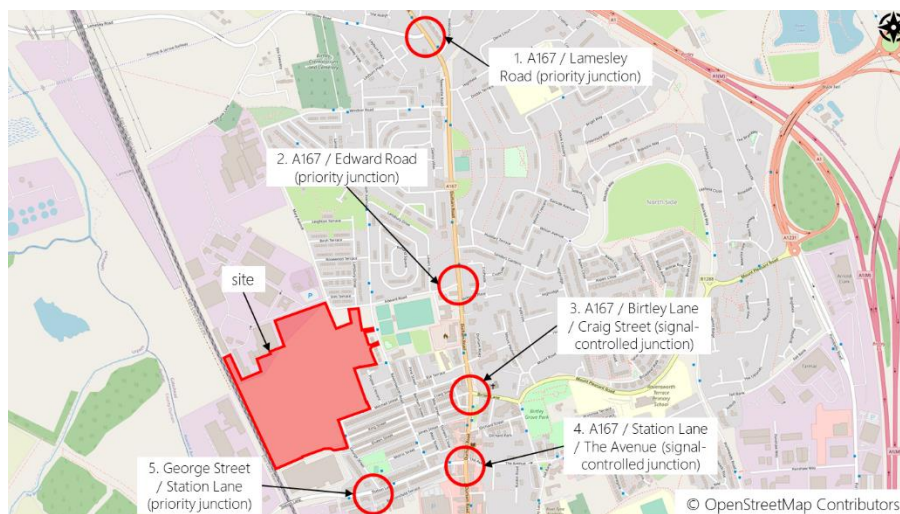

- 9.6 The data obtained from the surveys includes traffic flows for the AM and PM peak hours as well as queue counts for each of the junctions.
- 9.7 The AM and PM 2022 baseline distributions at these junctions are included as Appendix 7. The peak hours have been established as 08:00-09:00 in the morning and 17:00-18:00 in the evening.

Future Traffic Flows

- 9.8 The TEMPro database has then been used to establish growth rates for a 2028 'future year' baseline scenario. The use of TEMPro growth rates have been agreed with GC as they are considered robust for junction assessments. The 2028 baseline AM and PM distributions are attached as Appendix 8.

Development Traffic

- 9.9 As previously discussed, development traffic has been calculated using the TRICS database and has been routed using the distribution and assignments gained from a Google Maps routeing exercise. It is also of note that the initial trip generation and distribution was based on a site of 298 dwellings, which has since decreased to 292. It is considered that the trip generation for a site of 298 dwellings is a robust representation for a site of 292 dwellings, and therefore the impact assessments have been undertaken using the distribution for a site of 298 dwellings.
- 9.10 The predicted AM and PM peak development traffic flows are included at Appendix 9.

Committed Development Traffic

- 9.11 Following discussions with GC it was requested that a number of committed/anticipated developments are included in the junction assessments, including residential schemes at Birtley Northside, Vigo Lane and Kibblesworth and an industrial development at Longshank Lane.
- 9.12 The developments at Birtley Northside include the planning applications DC/19/1250/FUL (for 23 dwellings) and DC/21/00774/FUL (for 73 dwellings). Application DC/19/1250/FUL is anticipated to generate 14 (two-way) vehicle movements during each peak hour and the TA considered that any traffic impact on the wider highway network would be insignificant. Application DC/21/00774/FUL is anticipated to generate 36 (two-way) movements in the AM peak and 40 (two-way) movements in the PM peak and this TA also concluded that movements of these numbers would not be significant on the wider highway network. As these developments are not considered to have a significant impact on the wider highway network they have not been considered within the junction assessments.
- 9.13 The committed development at Vigo Lane is for the planning application DM/18/00828/OUT. It is predicted within the TA for this development that only 1 vehicle movement during each peak hour will head north on the A167(Durham Road), this is considered to be insignificant and therefore has not been considered further within the junction assessments.
- 9.14 The anticipated development at Kibblesworth is for planning application DC/16/01207/OUT. The extent of the traffic generated by the site ceases at the Lamesley Road/A167 (Newcastle Bank) junction. It has therefore been assumed that traffic heading south on the A167 will split 50% onto Birtley Lane and 50% to the south of Birtley on the A167, because these from the routes to the two main employment areas in the vicinity of the site.

9.15 The anticipated development at Longshank Lane is planning application DC/21/00938/FUL. The extent of the traffic generated by the site ceases at the Lamesley Road/A167 (Newcastle Bank) junction. It is therefore assumed that all vehicles from this development heading south on the A167 will be going south through Birtley to join the A1(M) southbound at Chester-le-Street and vehicles heading north on the A167 will be going to join the A1(M) northbound.

9.16 Overall, the developments that have been considered for junction assessment purposes are the planning applications at Kibblesworth and Longshank Lane. The total number of traffic movements from the two developments for the AM and PM peaks are attached as Appendix 10.

Assessment Scenarios

9.17 Overall, the following scenarios have been assessed for each of the junctions surveyed:

- 2022 Baseline, taken from the junction survey counts;
- 2028 Future, taken from the 2022 data that had been growthed to predict 2028 traffic flows, and;
- 2028 Future + Committed Developments + Proposed Development traffic.

9.18 The total traffic flows for 2028, including the committed developments and proposed development traffic, for the AM and PM peaks are included as Appendix 11.

Junctions 9 Assessment Software

9.19 Three of the junctions were modelled using the Junctions9 modelling software. The computer software reports the operation of each arm of a junction based on the Ratio of Flow to Capacity (RFC), the Mean Maximum Queue (MMQ) and its Level of Service (LoS).

9.20 An RFC value that is less than 0.85 is generally considered to show that a junction is operating under capacity. Values between 0.85 and 1.0 indicate that the junction is approaching capacity, and values over 1.0 suggest the junction is operating over capacity.

9.21 MMQ represents an average of the maximum queues recorded during the peak hour.

9.22 The LoS figure combines that RFC, MMQ and delay time for vehicles using the arm. The LoS is presented on a scale of A-F, with A being reported for arms with no issues and F being reported when an arm is considered to have failed as a result of a combination of the three factors.

9.23 Each junction has been assessed using the 'ONE HOUR' method, which creates a bell curve profile for the peak hour traffic, i.e. it predicts a short-term peak within the overall peak hour. This is considered to be robust in terms of traffic capacity assessments.

9.24 Although the baseline traffic counts and development flows are reported in passenger car units (PCUs), the software still requires percentages of heavy goods vehicle to be manually input. The software then uses these to adjust the vehicle speeds through the junction. In this case, HGV percentages have been worked out as a percentage of the total traffic counted at each arm from the survey results.

9.25 The geometric parameters used within the software are based on ariel imagery and are recorded in the output files, which are included as Appendix 12.

LinSig Assessment Software

- 9.26 Two of the junctions were modelled using the LinSig computer modelling software. The signal stages and traffic signal phase times for each junction have been derived from the controller specifications, obtained from GC. The full controller specifications are attached as Appendix 13.
- 9.27 The LinSig software reports the operation of each arm through a Degree of Saturation (DoS), and the MMQ for each link.
- 9.28 The DoS shows the demand and available capacity for each link of the junction. A DoS below 90% is generally considered to be representative of a junction operating under stable conditions. Values between 90% and 100% represent a constrained scenario, where there will be a possible build up of queues causing an increase in vehicle delay. A DoS value over 100% indicates overloaded conditions and a junctions that is operating beyond its capacity.
- 9.29 The MMQ output, as with Junctions 9, represents the average maximum queue recorded, in PCUs.
- 9.30 The geometric parameters of the junctions were measured using aerial imagery and are recorded in the full LinSig output files included in Appendix 14.

Assessment Findings

Junction 1

- 9.31 Junction 1, as shown in Figure 20 is the A167/Lamesley Road priority junction. It has arms which serve Birtley to the north and south, provide access to the A1 in the north, and provide access to Kibblesworth to the west.

Figure 20 A167 / Lamesley Road Priority Junction

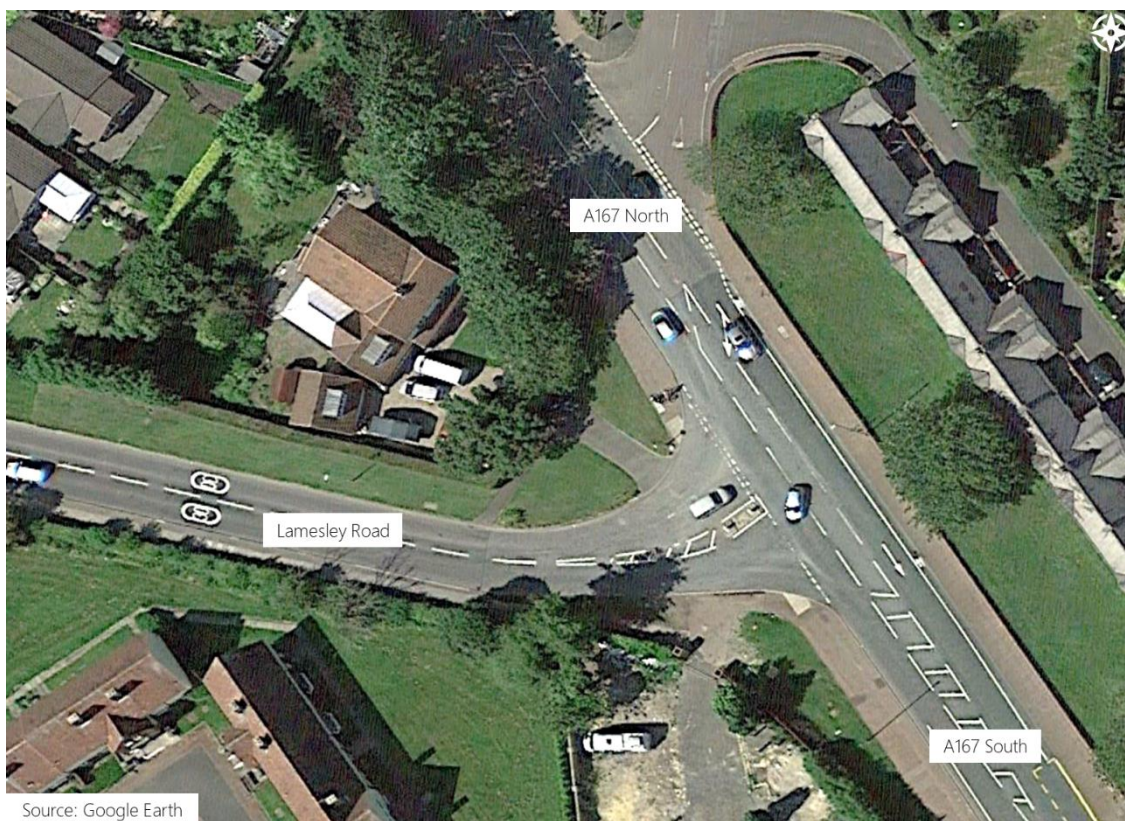

9.32 Table 9.1 provides a summary of the results for each of the scenarios assessed at the A167/Lamesley Road priority junction.

Table 9.1 A167 / Lamesley Road Priority Junction Assessment Summary

Arm	AM Peak			PM Peak		
	Max RFC	MMQ (PCU)	LoS	Max RFC	MMQ (PCU)	LoS
2022 Base Scenarios						
Lamesley Road to A167 North	0.26	0.4	C	0.85	3.7	F
Lamesley Road to A167 South	0.63	2.0	D	0.92	8.1	F
A167 North to Lamesley Road	0.14	0.2	B	0.26	0.4	B
2028 Future Scenarios						
Lamesley Road to A167 North	0.30	0.5	C	1.01	6.6	F
Lamesley Road to A167 South	0.68	2.5	D	1.01	14.5	F
A167 North to Lamesley Road	0.15	0.2	B	0.28	0.5	B
2028 Future + Committed Developments + Proposed Development Scenarios						
Lamesley Road to A167 North	0.56	1.5	E	1.19	11.5	F
Lamesley Road to A167 South	0.84	5.2	F	1.17	32.7	F
A167 North to Lamesley Road	0.17	0.3	B	0.33	0.6	B

9.33 The results from Table 9.1 show even with current traffic levels, the junction is approaching capacity during the PM peak, with relatively low queues. Under the 2028 Future PM peak scenario, the junction is shown to be operating slightly over capacity and there is nearly a doubled increase (from the 2022 baseline) in the average queue lengths on the Lamesley Road arm. With the addition of the committed

development and proposed development traffic, the Lamesley Road arm is shown to be operating well over capacity with an increase of nearly double the queues from the 2028 Future scenario.

Junction 2

9.34 Junction 2, as shown in Figure 21, is the A167/Edward Road priority junction, which has arms that serve the various residential estates and amenities/facilities within Birtley.

Figure 21 A167 / Edward Road Priority Junction

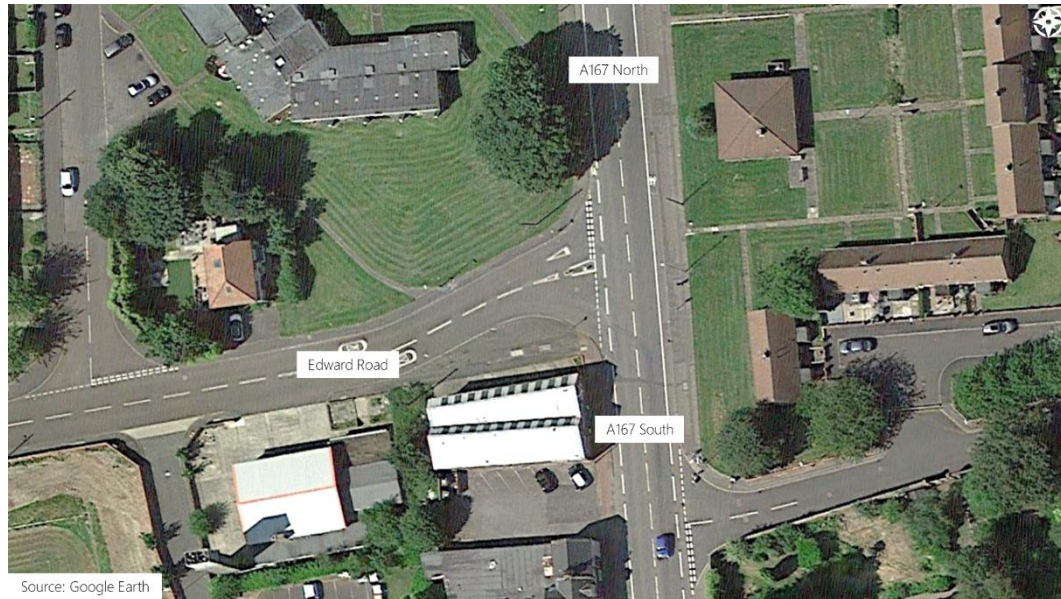

9.35 Table 9.2 provides a summary of the results for each of the scenarios assessed at this junction

Table 9.2 A167 / Edward Road Priority Junction Assessment Summary

Arm	AM Peak			PM Peak		
	Max RFC	MMQ (PCU)	LoS	Max RFC	MMQ (PCU)	LoS
2022 Base Scenarios						
Edward Road to A167 North and A167 South	0.17	0.2	B	0.18	0.3	B
A167 North to Edward Road and A167 South	0.22	0.7	A	0.22	0.8	A
2028 Future Scenarios						
Edward Road to A167 North and A167 South	0.18	0.3	B	0.19	0.3	B
A167 North to Edward Road and A167 South	0.25	0.8	A	0.24	0.9	A
2028 Future + Committed Developments + Proposed Development Scenarios						
Edward Road to A167 North and A167 South	0.37	0.7	B	0.30	0.5	B
A167 North to Edward Road and A167 South	0.31	1.1	A	0.46	2.1	A

9.36 Overall, the results from Table 9.2 show that under each scenario, the Edward Road junction would operate well under capacity in both the AM and PM peak periods, even with the addition of committed and proposed development traffic. Therefore, no mitigation is considered necessary at this junction.

Junction 3

9.37 Junction 3, as shown in Figure 22, is the George Street/Station Lane priority junction, which has arms that serve some of the residential estates and facilities within Birtley and links to Ouston in the west.

Figure 22 George Street / Station Lane Priority Junction



9.38 Table 9.3 provides a summary of the results for the AM and PM scenarios assessed at this junction.

Table 9.3 George Street / Station Lane Priority Junction Assessment Summary

Arm	AM Peak			PM Peak		
	Max RFC	MMQ (PCU)	LoS	Max RFC	MMQ (PCU)	LoS
2022 Base Scenarios						
George Street to Station Lane East and Station Lane West	0.03	0.0	A	0.04	0.1	A
Station Lane West to Station Lane East and George Street	0.03	0.0	A	0.02	0.0	A
2028 Future Scenarios						
George Street to Station Lane East and Station Lane West	0.03	0.0	A	0.05	0.1	A
Station Lane West to Station Lane East and George Street	0.03	0.1	A	0.03	0.0	A
2028 Future + Committed Developments + Proposed Development Scenarios						
George Street to Station Lane East and Station Lane West	0.11	0.1	B	0.08	0.1	A
Station Lane West to Station Lane East and George Street	0.04	0.1	A	0.05	0.1	A

9.39 Overall, Table 9.3 shows that under all three scenarios, the George Street/Station Lane priority junction would operate will under capacity with negligible queue lengths, even with the inclusion of development traffic. It is therefore considered that no mitigation is necessary here.

Junction 4

9.40 Junction 4, as shown in Figure 23, is the A167/Birtley Lane/Craig Street signal-controlled junction. It provides links to the A1, as well as the residential areas of Birtley. It is of note that Craig Street is a one-way street, which can only be used to exit the junction.

Figure 23 A167 / Birtley Lane / Craig Street Signal-Controlled Junction



Source: Google Earth

9.41 Table 9.4 provides a summary of the LinSig results for the scenarios assessed at this junction.

Table 9.4 A167 / Birtley Lane / Craig Street Signal-Controlled Junction Assessment Summary

Approach	AM Peak		PM Peak	
	MMQ (PCU)	DoS (%)	MMQ (PCU)	DoS (%)
2022 Base Scenarios				
A167 Durham Road (southbound)	14.1	73.4%	14.7	76.0%
Birtley Lane (left)	3.8	62.5%	5.8	75.6%
Birtley Lane (right)	4.7	74.1%	4.7	76.8%
A167 Durham Road (northbound)	2.8	55.5%	3.1	54.0%
2028 Future Scenarios				
A167 Durham Road (southbound)	15.4	77.4%	16.2	79.9%
Birtley Lane (left)	4.1	65.5%	6.4	79.3%
Birtley Lane (right)	5.2	77.9%	5.2	81.0%
A167 Durham Road (northbound)	3.0	57.9%	3.3	56.5%
2028 Future + Committed Developments + Proposed Development Scenarios				
A167 Durham Road (southbound)	18.3	84.1%	19.1	87.3%
Birtley Lane (left)	4.3	67.4%	7.6	85.5%

Birtley Lane (right)	6.3	84.8%	6.2	84.3%
A167 Durham Road (northbound)	3.8	67.4%	3.6	60.5%

9.42 Overall, the results presented in Table 9.4 show that for each turning movement, the signalised junction would operate well, under stable conditions, especially with the addition of committed and proposed development traffic. Therefore, no mitigation is considered necessary at this junction.

Junction 5

9.43 Junction 5, as shown in figure 24, is the A167/Station Lane/The Avenue signal-controlled junction. It offers links to residential areas and facilities within close proximity to the main shopping centre of Birtley. It is of note that The Avenue is a one-way street, which can only be used to exit the junction.

Figure 24 A167 / Station Lane / The Avenue Signal-Controlled Junction

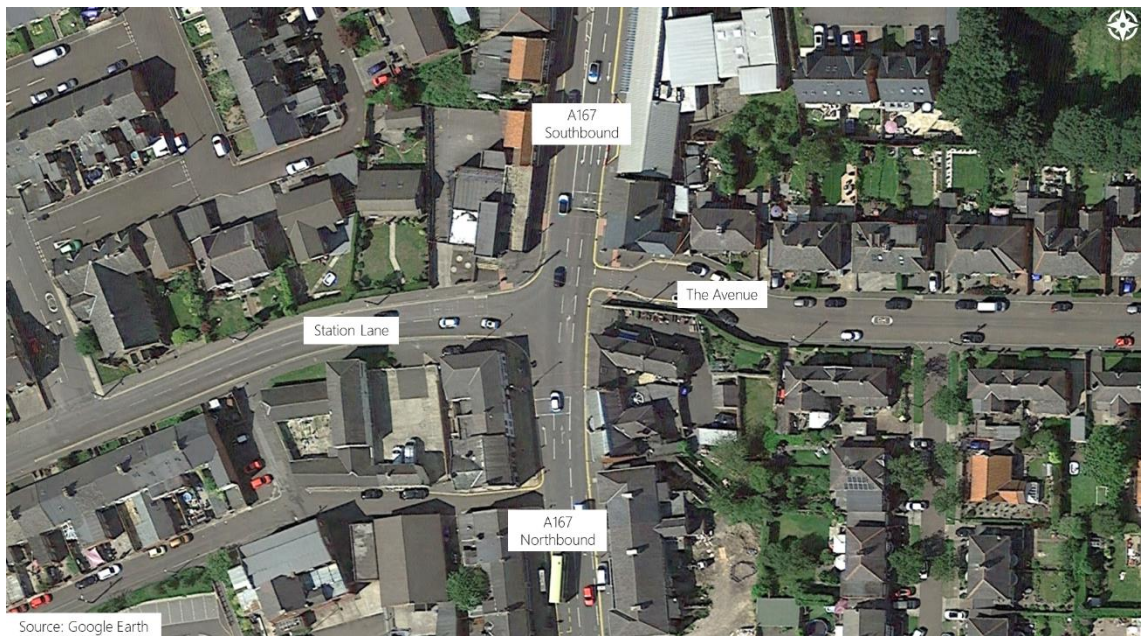

9.44 Table 9.5 provides a summary of the LinSig outputs for each of the scenarios assessed at the A167 /Station Lane/The Avenue signalised junction.

Table 9.5 A167 / Station Lane / The Avenue Signal-Controlled Junction Assessment Summary

Approach	AM Peak		PM Peak	
	MMQ (PCU)	DoS (%)	MMQ (PCU)	DoS (%)
2022 Base Scenarios				
A167 Durham Road (southbound) – Ahead/Left	6.3	42.5%	9.3	55.7%
A167 Durham Road (southbound) – Right	5.0	69.2%	5.3	72.2%
A167 Durham Road (northbound)	6.6	68.6%	9.7	72.0%
Station Lane	9.7	69.0%	9.3	73.6%
2028 Future Scenarios				

A167 Durham Road (southbound) – Ahead/Left	6.7	44.7%	10.1	58.5%
A167 Durham Road (southbound) – Right	5.3	72.6%	5.8	76.1%
A167 Durham Road (northbound)	7.5	72.2%	10.7	75.7%
Station Lane	10.4	72.4%	10.2	77.4%
2028 Future + Committed Developments + Proposed Development Scenarios				
A167 Durham Road (southbound) – Ahead/Left	7.4	48.5%	10.4	59.9%
A167 Durham Road (southbound) – Right	5.6	74.8%	6.1	75.6%
A167 Durham Road (northbound)	8.2	74.7%	12.3	81.8%
Station Lane	11.4	76.8%	10.6	79.8%

9.45 The results show that this signal-controlled junction would continue to operate under stable conditions in the future year scenarios, even with the addition of development traffic. As such, it is considered that no mitigation measures are required at this junction.

Review of Previous Mitigation Measures

9.46 As previously discussed, the initial accessibility audit found nine key areas for improvements. A review of these issues found that two had been resolved and one was considered no longer relevant as the primary school has since been relocated. No additional issues were found, as such it was concluded that a contribution would be made towards the remedial works for the remaining six issues found within the accessibility audit.

9.47 In addition to these remedial works, it was agreed as part of the initial outline that a contribution would be made towards to traffic calming works, including a provision of lining and speed cushions, required on Mary Avenue.

9.48 This revised TA, shows that no traffic generated by the site is expected to use Mary Avenue for normal day-to-day trips, as it is anticipated that all trips from the northern access will use Edward Road to access the A167. As Mary Avenue would not be trafficked by residents of this development, it is therefore considered that the developer would not be liable for any contributions to traffic calming measures along this road.

Additional Mitigation Measures

9.49 In relation to the updated accessibility audit, the developer will agree contributions with GC towards the remedial works for the six key issues found.

9.50 In addition to this, Lamesley Road is shown to be currently under pressure with increasing queues and operation over capacity in the 2028 Future scenario, which the development traffic exacerbates further. As such, it is proposed that widening works are carried out at the junction, on the northern side of Lamesley Road, to reduce queues, delay times and improve the overall functionality of the junction. The full extent of the proposed works is to be agreed with GC.

10. Construction Phase

- 10.1 The construction period for the development is yet to be confirmed but will be agreed with GC.
- 10.2 During the construction phases, it is understood that access to the site will be gained from Edward Road and the access at Mitchell Street/George Street, although the best location for construction access will be agreed with GC as part of a Construction Traffic Management Plan (CTMP).
- 10.3 The CTMP will also address issues related to the location of the site compound and parking for construction staff.
- 10.4 The aim of the CTMP will be to minimise impacts on the users of the local highway network and the local residents during the construction phase.
- 10.5 The extent of the CTMP will be agreed with GC and will be submitted as part of the planning application.

11. Summary & Conclusions

11.1 Milestone Transport Planning Ltd has been appointed by Gleeson Regeneration Ltd to prepare this revised Transport Assessment (TA) and Travel Plan (TP) to accompany a planning application for a development of 292 dwellings.

11.2 The findings of this report can be summarised as follows:

- The application site is located to the east of the East Coast Main Line, to the west of an existing residential area of Birtley, to the north of Station Lane and to the south of existing industrial units.
- The application includes the construction of 292 dwellings, including 2, 3 and 4-bed units.
- Vehicular access to the site will be from Mitchell Street/George Street to the south of the site and form Edward Road to the north.
- Overall, the development will be very well connected to the surrounding highway network.
- The overall local highway network is of a good standard to serve the development and the A1 is currently being improved as part of a National Highways scheme.
- Overall, the site is very accessible by sustainable modes of transport, with a range of bus services to local conurbations and cities.
- The site is also well placed for a large range of local amenities on the A167 within reasonable walking and cycling distances.
- A review of the accessibility audit, undertaken for the initial outline application, shows that there are six existing issues relating to a lack of dropped kerbs that should be addressed to aid the accessibility of the site. The developer will agree with GC a level of contributions towards the remedial works needed to rectify these issues.
- A Travel Plan strategy will be implemented to encourage sustainable travel by residents and will aim to reduce the number of single-occupancy private car journeys. The measures within the Travel Plan have been based on the existing Travel Plans in the surrounding Birtley area.
- The development includes adequate parking in line with Gateshead Council guidance, providing 464 resident spaces (including 108 garage spaces), and 79 visitor spaces, which is considered acceptable for this development.
- Cycle parking will be provided in accordance with Gateshead Council guidance by including secure storage within each dwelling plot. This could be in the form of a garage or shed with a Sheffield bike stand.
- A review of personal injury collision data shows that there are no patterns or clusters of incidents in the context of the site that would cause concern for the safety of the junctions within the vicinity of the site.
- Comments from the council requested that the trip rates from the outline application should be used, these are considered to be out-of-date, so the proposed trip rates are considered to provide more representative and up-to-date predictions.
- As a baseline, the TRICS data suggests that during the morning peak the development will generate approximately 147 two-way vehicles movements and in the evening peak will generate approximately 163 two-way movements.

- Based on the TRICS data, six junctions were identified for further assessments. As such junction counts were undertaken and the junctions were modelled in the Junctions 9 and LinSig computer software. It was considered that all but one of the junctions were currently operating well within the junctions capacity and would continue to operate under capacity with the addition of committed developments and the proposed development traffic.
- One of the modelled junctions (A167/Lamesley Road) was shown to currently be approaching capacity with the growth scenario causing the junction to operate just over capacity. The addition of committed and the proposed development traffic is predicted to cause the junction to operate well over capacity, with large queues forming on the Lamesley Road arm.
- It is proposed that widening works on the northern side of Lamesley Road would improve the overall functionality of the A167/Lamesley Road junction. The developer will agree a level of works and necessary funding with GC to contribute towards the works suggested.
- Other than the A167/Lamesley Road junction, it is generally considered that the local highway network in the vicinity of the site is considered to have no capacity issues, and as predicted the site is shown to have no significant impact on the overall flow of the local highway network.
- The construction access and phasing is to be agreed with GC and Construction Traffic Management Plan will be implemented to minimise the impact of construction traffic on the local highway network.

11.3 It is considered that the site is in an appropriate location for a residential development and is ideally placed for local amenities and sustainable transport. It is also considered that the site will have no significant impact to the safety of the local highway network and it is likely that the subsequent impact assessment will not highlight any significant capacity constraints in relation to the predicted traffic flows generated by the site.

11.4 In conclusion, the proposed development would ensure a low number of single-occupancy car journeys through the implementation of a Travel Plan, there will be no impact to the safety of the local highway network and it is anticipated that the site will have no significant negative impacts on the capacity of the surrounding highways. Therefore, the proposal should not be refused planning permission on transportation grounds.

Appendix 1

Appendix 2

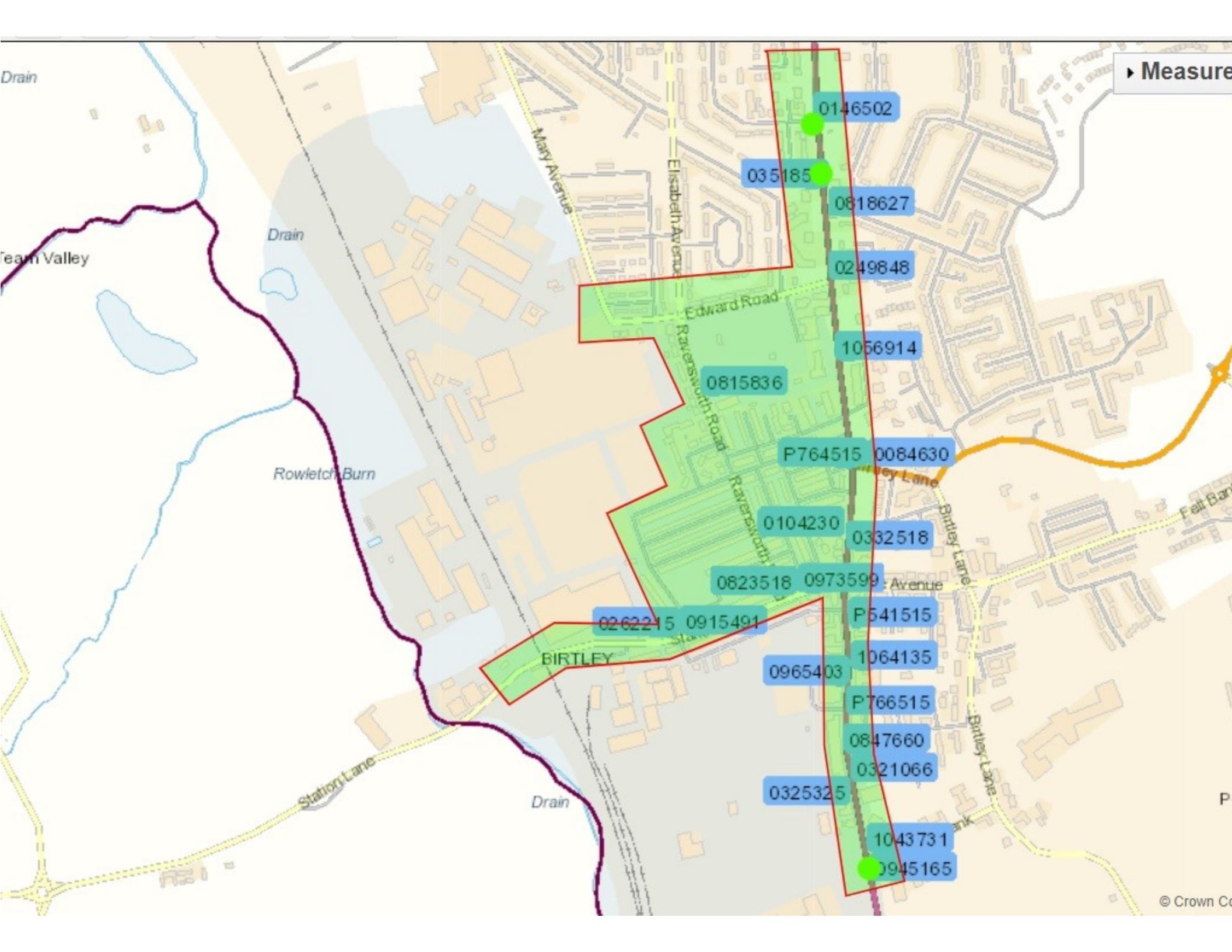

► Measure

0146502

035185

0818627

0249848

1056914

0815836

P764515 0084630

0104230

0332518

0823518 0973599

0262215 0915491

P541515

1064135

0965403

P766515

0847660

0321066

0325325

1043731

0945165

BIRTLEY

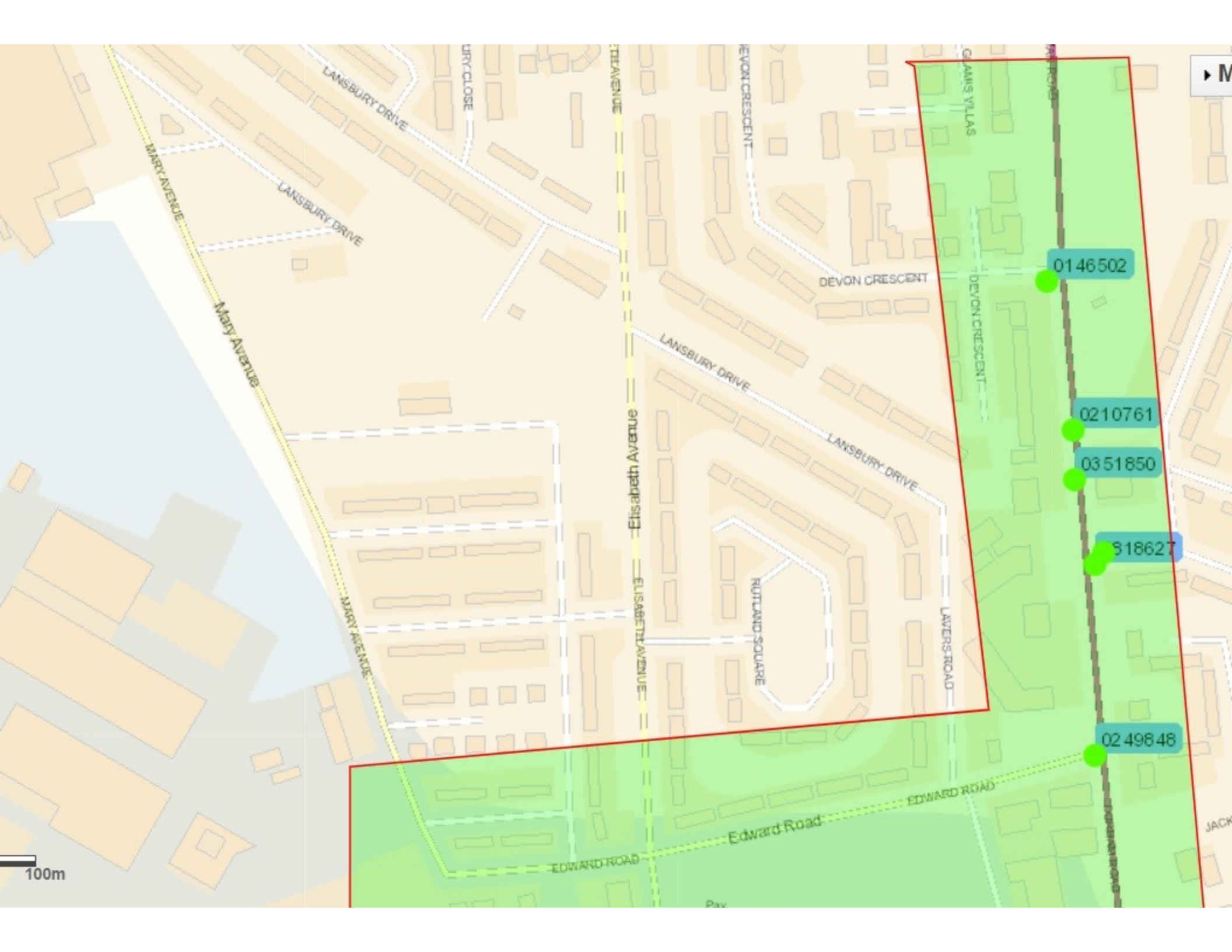

MARY AVENUE
Mary Avenue

LANSBURY DRIVE

JUDDY AVENUE

ELISABRETH AVENUE

LANSBURY DRIVE

RUTLAND SQUARE

LANSBURY DRIVE

LAVERS ROAD

Edward Road

Edward Road

LANSBURY DRIVE

DRY CLOSE

THE AVENUE

DEVON CRESCENT

DEVON CRESCENT

GLANIS VILLAS

DEVON CRESCENT

► M

0146502

0210761

0351850

918627

0249848

100m

JACK

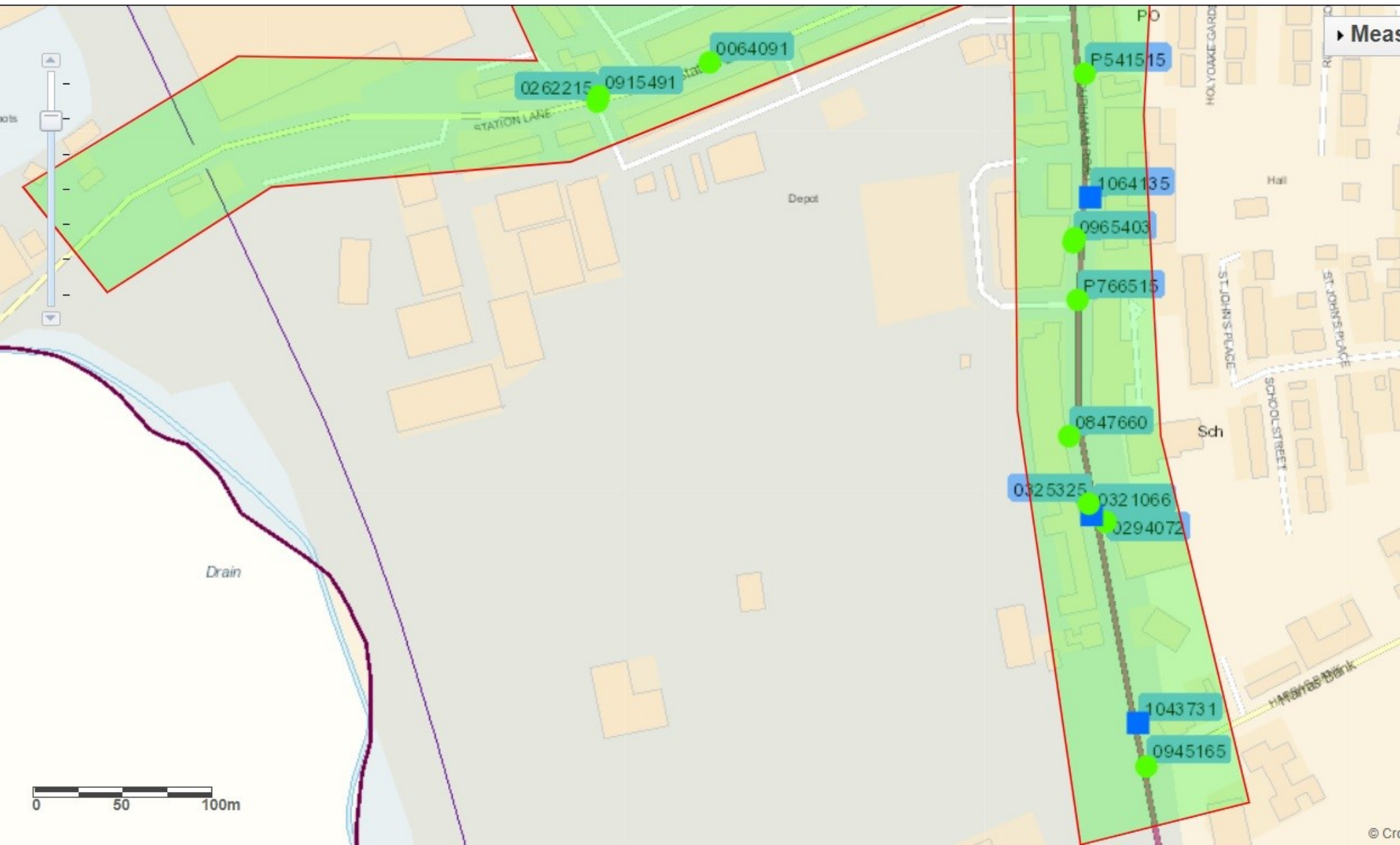

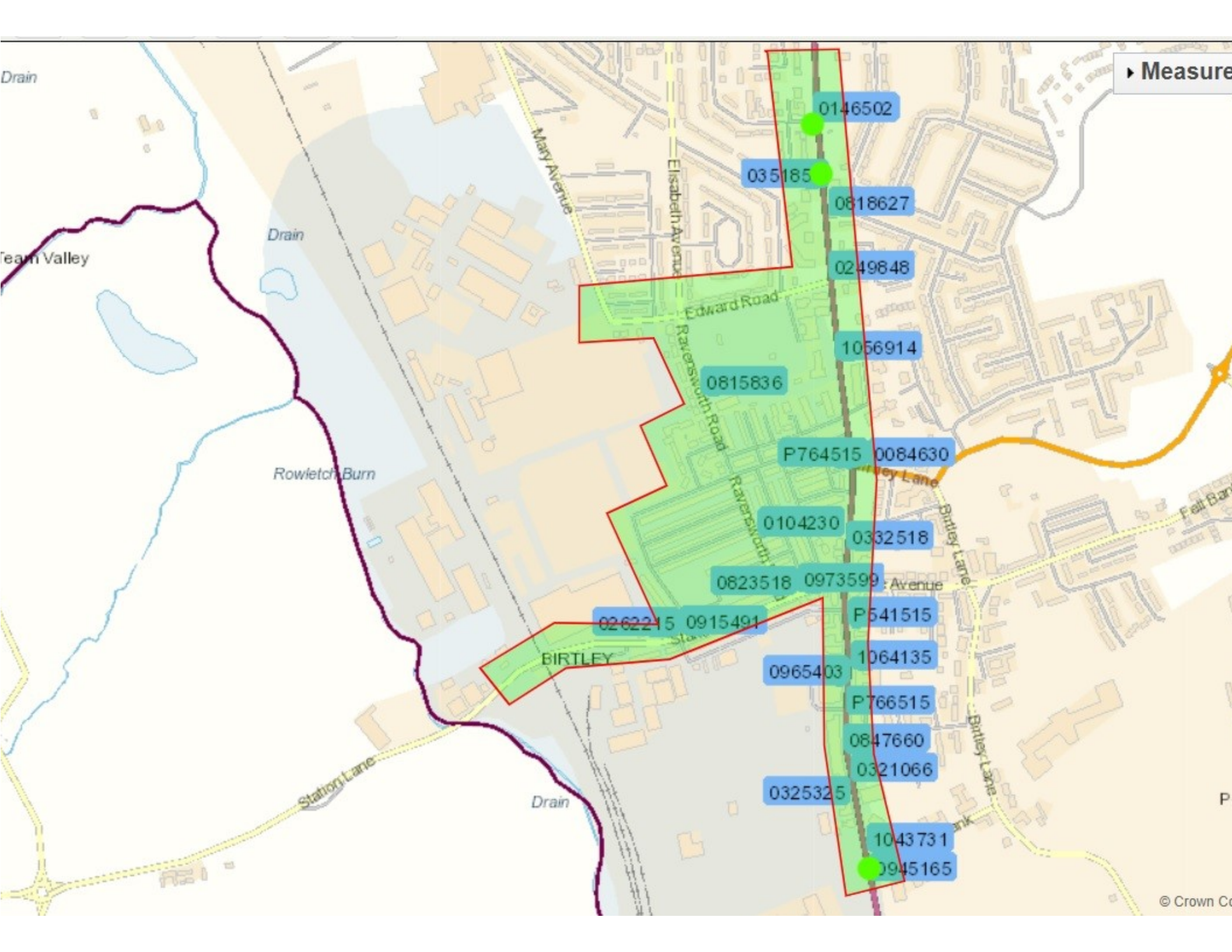

Appendix 3

Mitchell Street- George Street, Birtley Date: Thursday 9th June 2022				
19:00				
Section /Street Name				
A- George St btwn King St & Queen St	East Side	0	West Side	0
B- George St btwn Mitcell St & King St	East Side	1	West Side	0
C- Mitchell St btwn Poplar Cres & George St	North Side	12	South Side	14
D- Mitchell St btwn Ravensworth Rd & Poplar Cres	North Side	1	South Side	5

Mitchell Street- George Street, Birtley Date: Saturday 11th June 2022				
19:00				
Section /Street Name				
A- George St btwn King St & Queen St	East Side	0	West Side	0
B- George St btwn Mitcell St & King St	East Side	1	West Side	2
C- Mitchell St btwn Poplar Cres & George St	North Side	8	South Side	18
D- Mitchell St btwn Ravensworth Rd & Poplar Cres	North Side	0	South Side	6

Appendix 4



INDICATIVE

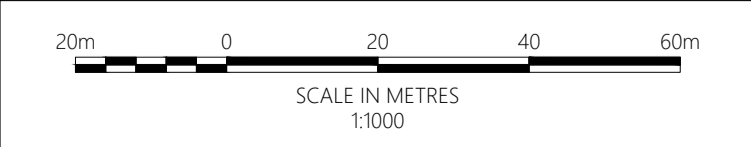

Notes

1. Do not scale from this drawing. All dimensions shown are in metres unless noted otherwise.
2. This drawing has been based upon topographical survey information produced by others and Milestone Transport Planning cannot be held responsible for any discrepancies which may arise because of it.

Vehicle Profile

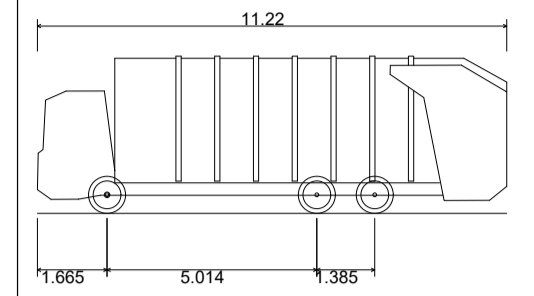

Phoenix 2 Duo Recycler (P2-15W with Elite 6x4 chassis)
 Overall Length 11.220m
 Overall Width 2.530m
 Overall Body Height 3.756m
 Min Body Ground Clearance 0.309m
 Track Width 2.530m
 Lock to lock time 4.00s
 Kerb to Kerb Turning Radius 11.550m

Ordnance Survey Licence number: 100057360

Drawing Revisions

Rev:	Drn:	Date:	Details:	Chk:
-	JW	15/06/2022	First issue	DK
A	JW	22/06/2023	Updated layout / tracking	DK
B	JW	23/06/2023	Updated layout	DK
C	AW	21/08/2023	Updated layout	DK
D	AW	24/08/2023	Updated layout	JW

Client

Gleeson Regeneration Ltd

Project
 Proposed Residential Development, BAE, Ravensworth Road, Birtley, Gateshead

Title
 Internal Site Movements - Swept Path Analysis



7 Ancells Court, Rye Close, Fleet, Hampshire, GU51 2UY
 Tel: 01483 397888
 Gateshead IBC, Mulgrave Terrace, Gateshead, NE8 1AN
 Tel: 0191 338 7220
 web: www.milestonetp.co.uk

Drawing Number:

22-024/TK02

Scale:

1:1000 @ A1

Revision:

D

Appendix 5

Calculation Reference: AUDIT-740101-210924-0911

TRIP RATE CALCULATION SELECTION PARAMETERS:

Land Use : 03 - RESIDENTIAL
 Category : A - HOUSES PRIVATELY OWNED
 MULTI-MODAL TOTAL VEHICLES

Selected regions and areas:

02	SOUTH EAST	
	HC HAMPSHIRE	2 days
	KC KENT	2 days
03	SOUTH WEST	
	DV DEVON	1 days
	WL WILTSHIRE	1 days
04	EAST ANGLIA	
	SF SUFFOLK	1 days
07	YORKSHIRE & NORTH LINCOLNSHIRE	
	NY NORTH YORKSHIRE	1 days
	SY SOUTH YORKSHIRE	1 days
08	NORTH WEST	
	CH CHESHIRE	1 days
09	NORTH	
	DH DURHAM	1 days
11	SCOTLAND	
	FA FALKIRK	2 days
	HI HIGHLAND	1 days

This section displays the number of survey days per TRICS® sub-region in the selected set

Primary Filtering selection:

This data displays the chosen trip rate parameter and its selected range. Only sites that fall within the parameter range are included in the trip rate calculation.

Parameter: No of Dwellings
 Actual Range: 10 to 363 (units:)
 Range Selected by User: 6 to 1817 (units:)

Parking Spaces Range: All Surveys Included

Parking Spaces per Dwelling Range: All Surveys Included

Bedrooms per Dwelling Range: All Surveys Included

Percentage of dwellings privately owned: All Surveys Included

Public Transport Provision:

Selection by: Include all surveys

Date Range: 01/01/13 to 08/10/20

This data displays the range of survey dates selected. Only surveys that were conducted within this date range are included in the trip rate calculation.

Selected survey days:

Tuesday	3 days
Wednesday	6 days
Thursday	5 days

This data displays the number of selected surveys by day of the week.

Selected survey types:

Manual count	14 days
Directional ATC Count	0 days

This data displays the number of manual classified surveys and the number of unclassified ATC surveys, the total adding up to the overall number of surveys in the selected set. Manual surveys are undertaken using staff, whilst ATC surveys are undertaken using machines.

Selected Locations:

Suburban Area (PPS6 Out of Centre) 14

This data displays the number of surveys per main location category within the selected set. The main location categories consist of Free Standing, Edge of Town, Suburban Area, Neighbourhood Centre, Edge of Town Centre, Town Centre and Not Known.

This data displays the number of surveys per location sub-category within the selected set. The location sub-categories consist of Commercial Zone, Industrial Zone, Development Zone, Residential Zone, Retail Zone, Built-Up Zone, Village, Out of Town, High Street and No Sub Category.

Secondary Filtering selection:

Use Class:

C3 14 days

This data displays the number of surveys per Use Class classification within the selected set. The Use Classes Order 2005 has been used for this purpose, which can be found within the Library module of TRICS@.

Population within 500m Range:

All Surveys Included

Population within 1 mile:

5,001 to 10,000	5 days
15,001 to 20,000	4 days
20,001 to 25,000	2 days
25,001 to 50,000	3 days

This data displays the number of selected surveys within stated 1-mile radii of population.

Population within 5 miles:

25,001 to 50,000	2 days
50,001 to 75,000	4 days
75,001 to 100,000	3 days
100,001 to 125,000	1 days
125,001 to 250,000	3 days
250,001 to 500,000	1 days

This data displays the number of selected surveys within stated 5-mile radii of population.

Car ownership within 5 miles:

0.6 to 1.0	4 days
1.1 to 1.5	10 days

This data displays the number of selected surveys within stated ranges of average cars owned per residential dwelling, within a radius of 5-miles of selected survey sites.

Travel Plan:

Yes	4 days
No	10 days

This data displays the number of surveys within the selected set that were undertaken at sites with Travel Plans in place, and the number of surveys that were undertaken at sites without Travel Plans.

PTAL Rating:

No PTAL Present	14 days
-----------------	---------

This data displays the number of selected surveys with PTAL Ratings.

LIST OF SITES relevant to selection parameters

1	CH-03-A-11	TOWN HOUSES		CHESHIRE
	LONDON ROAD			
	NORTHWICH			
	LEFTWICH			
	Suburban Area (PPS6 Out of Centre)			
	Residential Zone			
	Total No of Dwellings:		24	
	Survey date: THURSDAY		06/06/19	Survey Type: MANUAL
2	DH-03-A-01	SEMI DETACHED		DURHAM
	GREENFIELDS ROAD			
	BISHOP AUCKLAND			
	Suburban Area (PPS6 Out of Centre)			
	Residential Zone			
	Total No of Dwellings:		50	
	Survey date: TUESDAY		28/03/17	Survey Type: MANUAL
3	DV-03-A-01	TERRACED HOUSES		DEVON
	BRONSHILL ROAD			
	TORQUAY			
	Suburban Area (PPS6 Out of Centre)			
	Residential Zone			
	Total No of Dwellings:		37	
	Survey date: WEDNESDAY		30/09/15	Survey Type: MANUAL
4	FA-03-A-01	SEMI -DETACHED/TERRACED		FALKIRK
	MANDELA AVENUE			
	FALKIRK			
	Suburban Area (PPS6 Out of Centre)			
	Residential Zone			
	Total No of Dwellings:		37	
	Survey date: THURSDAY		30/05/13	Survey Type: MANUAL
5	FA-03-A-02	MIXED HOUSES		FALKIRK
	ROSEBANK AVENUE & SPRINGFIELD DRIVE			
	FALKIRK			
	Suburban Area (PPS6 Out of Centre)			
	Residential Zone			
	Total No of Dwellings:		161	
	Survey date: WEDNESDAY		29/05/13	Survey Type: MANUAL
6	HC-03-A-18	HOUSES & FLATS		HAMPSHIRE
	CANADA WAY			
	LIPHOOK			
	Suburban Area (PPS6 Out of Centre)			
	Residential Zone			
	Total No of Dwellings:		62	
	Survey date: TUESDAY		29/11/16	Survey Type: MANUAL
7	HC-03-A-23	HOUSES & FLATS		HAMPSHIRE
	CANADA WAY			
	LIPHOOK			
	Suburban Area (PPS6 Out of Centre)			
	Residential Zone			
	Total No of Dwellings:		62	
	Survey date: TUESDAY		19/11/19	Survey Type: MANUAL

LIST OF SITES relevant to selection parameters (Cont.)

8	HI-03-A-14 KING BRUDE ROAD INVERNESS SCORGUIE Suburban Area (PPS6 Out of Centre) Residential Zone Total No of Dwellings: 40 <i>Survey date: WEDNESDAY 23/03/16</i>	SEMI-DETACHED & TERRACED	HIGHLAND	<i>Survey Type: MANUAL</i>
9	KC-03-A-03 HYTHE ROAD ASHFORD WILLESBOROUGH Suburban Area (PPS6 Out of Centre) Residential Zone Total No of Dwellings: 51 <i>Survey date: THURSDAY 14/07/16</i>	MIXED HOUSES & FLATS	KENT	<i>Survey Type: MANUAL</i>
10	KC-03-A-06 MARGATE ROAD HERNE BAY Suburban Area (PPS6 Out of Centre) Residential Zone Total No of Dwellings: 363 <i>Survey date: WEDNESDAY 27/09/17</i>	MIXED HOUSES & FLATS	KENT	<i>Survey Type: MANUAL</i>
11	NY-03-A-13 CATTERICK ROAD CATTERICK GARRISON OLD HOSPITAL COMPOUND Suburban Area (PPS6 Out of Centre) Residential Zone Total No of Dwellings: 10 <i>Survey date: WEDNESDAY 10/05/17</i>	TERRACED HOUSES	NORTH YORKSHIRE	<i>Survey Type: MANUAL</i>
12	SF-03-A-07 FOXHALL ROAD IPSWICH Suburban Area (PPS6 Out of Centre) Residential Zone Total No of Dwellings: 73 <i>Survey date: THURSDAY 09/05/19</i>	MIXED HOUSES	SUFFOLK	<i>Survey Type: MANUAL</i>
13	SY-03-A-01 A19 BENTLEY ROAD DONCASTER BENTLEY RISE Suburban Area (PPS6 Out of Centre) Residential Zone Total No of Dwellings: 54 <i>Survey date: WEDNESDAY 18/09/13</i>	SEMI DETACHED HOUSES	SOUTH YORKSHIRE	<i>Survey Type: MANUAL</i>
14	WL-03-A-02 HEADLANDS GROVE SWINDON Suburban Area (PPS6 Out of Centre) Residential Zone Total No of Dwellings: 27 <i>Survey date: THURSDAY 22/09/16</i>	SEMI DETACHED	WILTSHIRE	<i>Survey Type: MANUAL</i>

This section provides a list of all survey sites and days in the selected set. For each individual survey site, it displays a unique site reference code and site address, the selected trip rate calculation parameter and its value, the day of the week and date of each survey, and whether the survey was a manual classified count or an ATC count.

TRIP RATE for Land Use 03 - RESIDENTIAL/A - HOUSES PRIVATELY OWNED

MULTI-MODAL TOTAL VEHICLES

Calculation factor: 1 DWELLS

BOLD print indicates peak (busiest) period

Time Range	ARRIVALS			DEPARTURES			TOTALS		
	No. Days	Ave. DWELLS	Trip Rate	No. Days	Ave. DWELLS	Trip Rate	No. Days	Ave. DWELLS	Trip Rate
00:00 - 01:00									
01:00 - 02:00									
02:00 - 03:00									
03:00 - 04:00									
04:00 - 05:00									
05:00 - 06:00									
06:00 - 07:00									
07:00 - 08:00	14	75	0.065	14	75	0.303	14	75	0.368
08:00 - 09:00	14	75	0.107	14	75	0.387	14	75	0.494
09:00 - 10:00	14	75	0.141	14	75	0.167	14	75	0.308
10:00 - 11:00	14	75	0.114	14	75	0.160	14	75	0.274
11:00 - 12:00	14	75	0.127	14	75	0.144	14	75	0.271
12:00 - 13:00	14	75	0.177	14	75	0.149	14	75	0.326
13:00 - 14:00	14	75	0.167	14	75	0.174	14	75	0.341
14:00 - 15:00	14	75	0.157	14	75	0.185	14	75	0.342
15:00 - 16:00	14	75	0.227	14	75	0.159	14	75	0.386
16:00 - 17:00	14	75	0.300	14	75	0.159	14	75	0.459
17:00 - 18:00	14	75	0.365	14	75	0.184	14	75	0.549
18:00 - 19:00	14	75	0.281	14	75	0.174	14	75	0.455
19:00 - 20:00									
20:00 - 21:00									
21:00 - 22:00									
22:00 - 23:00									
23:00 - 24:00									
Total Rates:			2.228			2.345			4.573

This section displays the trip rate results based on the selected set of surveys and the selected count type (shown just above the table). It is split by three main columns, representing arrivals trips, departures trips, and total trips (arrivals plus departures). Within each of these main columns are three sub-columns. These display the number of survey days where count data is included (per time period), the average value of the selected trip rate calculation parameter (per time period), and the trip rate result (per time period). Total trip rates (the sum of the column) are also displayed at the foot of the table.

To obtain a trip rate, the average (mean) trip rate parameter value (TRP) is first calculated for all selected survey days that have count data available for the stated time period. The average (mean) number of arrivals, departures or totals (whichever applies) is also calculated (COUNT) for all selected survey days that have count data available for the stated time period. Then, the average count is divided by the average trip rate parameter value, and multiplied by the stated calculation factor (shown just above the table and abbreviated here as FACT). So, the method is: $COUNT/TRP*FACT$. Trip rates are then rounded to 3 decimal places.

The survey data, graphs and all associated supporting information, contained within the TRICS Database are published by TRICS Consortium Limited ("the Company") and the Company claims copyright and database rights in this published work. The Company authorises those who possess a current TRICS licence to access the TRICS Database and copy the data contained within the TRICS Database for the licence holders' use only. Any resulting copy must retain all copyrights and other proprietary notices, and any disclaimer contained thereon.

The Company accepts no responsibility for loss which may arise from reliance on data contained in the TRICS Database. [No warranty of any kind, express or implied, is made as to the data contained in the TRICS Database.]

Parameter summary

Trip rate parameter range selected:	10 - 363 (units:)
Survey date range:	01/01/13 - 08/10/20
Number of weekdays (Monday-Friday):	14
Number of Saturdays:	0
Number of Sundays:	0
Surveys automatically removed from selection:	2
Surveys manually removed from selection:	0

This section displays a quick summary of some of the data filtering selections made by the TRICS® user. The trip rate calculation parameter range of all selected surveys is displayed first, followed by the range of minimum and maximum survey dates selected by the user. Then, the total number of selected weekdays and weekend days in the selected set of surveys are shown. Finally, the number of survey days that have been manually removed from the selected set outside of the standard filtering procedure are displayed.

TRIP RATE for Land Use 03 - RESIDENTIAL/A - HOUSES PRIVATELY OWNED

MULTI-MODAL CYCLISTS

Calculation factor: 1 DWELLS

BOLD print indicates peak (busiest) period

Time Range	ARRIVALS			DEPARTURES			TOTALS		
	No. Days	Ave. DWELLS	Trip Rate	No. Days	Ave. DWELLS	Trip Rate	No. Days	Ave. DWELLS	Trip Rate
00:00 - 01:00									
01:00 - 02:00									
02:00 - 03:00									
03:00 - 04:00									
04:00 - 05:00									
05:00 - 06:00									
06:00 - 07:00									
07:00 - 08:00	14	75	0.004	14	75	0.012	14	75	0.016
08:00 - 09:00	14	75	0.000	14	75	0.017	14	75	0.017
09:00 - 10:00	14	75	0.000	14	75	0.006	14	75	0.006
10:00 - 11:00	14	75	0.004	14	75	0.002	14	75	0.006
11:00 - 12:00	14	75	0.003	14	75	0.001	14	75	0.004
12:00 - 13:00	14	75	0.005	14	75	0.008	14	75	0.013
13:00 - 14:00	14	75	0.002	14	75	0.001	14	75	0.003
14:00 - 15:00	14	75	0.002	14	75	0.001	14	75	0.003
15:00 - 16:00	14	75	0.021	14	75	0.003	14	75	0.024
16:00 - 17:00	14	75	0.006	14	75	0.002	14	75	0.008
17:00 - 18:00	14	75	0.003	14	75	0.002	14	75	0.005
18:00 - 19:00	14	75	0.009	14	75	0.003	14	75	0.012
19:00 - 20:00									
20:00 - 21:00									
21:00 - 22:00									
22:00 - 23:00									
23:00 - 24:00									
Total Rates:			0.059			0.058			0.117

This section displays the trip rate results based on the selected set of surveys and the selected count type (shown just above the table). It is split by three main columns, representing arrivals trips, departures trips, and total trips (arrivals plus departures). Within each of these main columns are three sub-columns. These display the number of survey days where count data is included (per time period), the average value of the selected trip rate calculation parameter (per time period), and the trip rate result (per time period). Total trip rates (the sum of the column) are also displayed at the foot of the table.

To obtain a trip rate, the average (mean) trip rate parameter value (TRP) is first calculated for all selected survey days that have count data available for the stated time period. The average (mean) number of arrivals, departures or totals (whichever applies) is also calculated (COUNT) for all selected survey days that have count data available for the stated time period. Then, the average count is divided by the average trip rate parameter value, and multiplied by the stated calculation factor (shown just above the table and abbreviated here as FACT). So, the method is: $COUNT/TRP*FACT$. Trip rates are then rounded to 3 decimal places.

TRIP RATE for Land Use 03 - RESIDENTIAL/A - HOUSES PRIVATELY OWNED

MULTI-MODAL PEDESTRIANS

Calculation factor: 1 DWELLS

BOLD print indicates peak (busiest) period

Time Range	ARRIVALS			DEPARTURES			TOTALS		
	No. Days	Ave. DWELLS	Trip Rate	No. Days	Ave. DWELLS	Trip Rate	No. Days	Ave. DWELLS	Trip Rate
00:00 - 01:00									
01:00 - 02:00									
02:00 - 03:00									
03:00 - 04:00									
04:00 - 05:00									
05:00 - 06:00									
06:00 - 07:00									
07:00 - 08:00	14	75	0.021	14	75	0.053	14	75	0.074
08:00 - 09:00	14	75	0.049	14	75	0.165	14	75	0.214
09:00 - 10:00	14	75	0.054	14	75	0.058	14	75	0.112
10:00 - 11:00	14	75	0.030	14	75	0.053	14	75	0.083
11:00 - 12:00	14	75	0.039	14	75	0.038	14	75	0.077
12:00 - 13:00	14	75	0.046	14	75	0.038	14	75	0.084
13:00 - 14:00	14	75	0.045	14	75	0.046	14	75	0.091
14:00 - 15:00	14	75	0.051	14	75	0.053	14	75	0.104
15:00 - 16:00	14	75	0.134	14	75	0.057	14	75	0.191
16:00 - 17:00	14	75	0.080	14	75	0.052	14	75	0.132
17:00 - 18:00	14	75	0.055	14	75	0.045	14	75	0.100
18:00 - 19:00	14	75	0.054	14	75	0.033	14	75	0.087
19:00 - 20:00									
20:00 - 21:00									
21:00 - 22:00									
22:00 - 23:00									
23:00 - 24:00									
Total Rates:			0.658			0.691			1.349

This section displays the trip rate results based on the selected set of surveys and the selected count type (shown just above the table). It is split by three main columns, representing arrivals trips, departures trips, and total trips (arrivals plus departures). Within each of these main columns are three sub-columns. These display the number of survey days where count data is included (per time period), the average value of the selected trip rate calculation parameter (per time period), and the trip rate result (per time period). Total trip rates (the sum of the column) are also displayed at the foot of the table.

*To obtain a trip rate, the average (mean) trip rate parameter value (TRP) is first calculated for all selected survey days that have count data available for the stated time period. The average (mean) number of arrivals, departures or totals (whichever applies) is also calculated (COUNT) for all selected survey days that have count data available for the stated time period. Then, the average count is divided by the average trip rate parameter value, and multiplied by the stated calculation factor (shown just above the table and abbreviated here as FACT). So, the method is: COUNT/TRP*FACT. Trip rates are then rounded to 3 decimal places.*

TRIP RATE for Land Use 03 - RESIDENTIAL/A - HOUSES PRIVATELY OWNED

MULTI-MODAL PUBLIC TRANSPORT USERS

Calculation factor: 1 DWELLS

BOLD print indicates peak (busiest) period

Time Range	ARRIVALS			DEPARTURES			TOTALS		
	No. Days	Ave. DWELLS	Trip Rate	No. Days	Ave. DWELLS	Trip Rate	No. Days	Ave. DWELLS	Trip Rate
00:00 - 01:00									
01:00 - 02:00									
02:00 - 03:00									
03:00 - 04:00									
04:00 - 05:00									
05:00 - 06:00									
06:00 - 07:00									
07:00 - 08:00	14	75	0.004	14	75	0.034	14	75	0.038
08:00 - 09:00	14	75	0.002	14	75	0.054	14	75	0.056
09:00 - 10:00	14	75	0.004	14	75	0.025	14	75	0.029
10:00 - 11:00	14	75	0.008	14	75	0.010	14	75	0.018
11:00 - 12:00	14	75	0.006	14	75	0.005	14	75	0.011
12:00 - 13:00	14	75	0.008	14	75	0.014	14	75	0.022
13:00 - 14:00	14	75	0.006	14	75	0.002	14	75	0.008
14:00 - 15:00	14	75	0.010	14	75	0.008	14	75	0.018
15:00 - 16:00	14	75	0.026	14	75	0.011	14	75	0.037
16:00 - 17:00	14	75	0.025	14	75	0.002	14	75	0.027
17:00 - 18:00	14	75	0.033	14	75	0.006	14	75	0.039
18:00 - 19:00	14	75	0.033	14	75	0.003	14	75	0.036
19:00 - 20:00									
20:00 - 21:00									
21:00 - 22:00									
22:00 - 23:00									
23:00 - 24:00									
Total Rates:			0.165			0.174			0.339

This section displays the trip rate results based on the selected set of surveys and the selected count type (shown just above the table). It is split by three main columns, representing arrivals trips, departures trips, and total trips (arrivals plus departures). Within each of these main columns are three sub-columns. These display the number of survey days where count data is included (per time period), the average value of the selected trip rate calculation parameter (per time period), and the trip rate result (per time period). Total trip rates (the sum of the column) are also displayed at the foot of the table.

To obtain a trip rate, the average (mean) trip rate parameter value (TRP) is first calculated for all selected survey days that have count data available for the stated time period. The average (mean) number of arrivals, departures or totals (whichever applies) is also calculated (COUNT) for all selected survey days that have count data available for the stated time period. Then, the average count is divided by the average trip rate parameter value, and multiplied by the stated calculation factor (shown just above the table and abbreviated here as FACT). So, the method is: $COUNT/TRP*FACT$. Trip rates are then rounded to 3 decimal places.

TRIP RATE for Land Use 03 - RESIDENTIAL/A - HOUSES PRIVATELY OWNED

MULTI-MODAL TOTAL PEOPLE

Calculation factor: 1 DWELLS

BOLD print indicates peak (busiest) period

Time Range	ARRIVALS			DEPARTURES			TOTALS		
	No. Days	Ave. DWELLS	Trip Rate	No. Days	Ave. DWELLS	Trip Rate	No. Days	Ave. DWELLS	Trip Rate
00:00 - 01:00									
01:00 - 02:00									
02:00 - 03:00									
03:00 - 04:00									
04:00 - 05:00									
05:00 - 06:00									
06:00 - 07:00									
07:00 - 08:00	14	75	0.118	14	75	0.529	14	75	0.647
08:00 - 09:00	14	75	0.172	14	75	0.853	14	75	1.025
09:00 - 10:00	14	75	0.233	14	75	0.318	14	75	0.551
10:00 - 11:00	14	75	0.199	14	75	0.289	14	75	0.488
11:00 - 12:00	14	75	0.214	14	75	0.242	14	75	0.456
12:00 - 13:00	14	75	0.292	14	75	0.269	14	75	0.561
13:00 - 14:00	14	75	0.284	14	75	0.290	14	75	0.574
14:00 - 15:00	14	75	0.265	14	75	0.311	14	75	0.576
15:00 - 16:00	14	75	0.548	14	75	0.294	14	75	0.842
16:00 - 17:00	14	75	0.577	14	75	0.281	14	75	0.858
17:00 - 18:00	14	75	0.659	14	75	0.330	14	75	0.989
18:00 - 19:00	14	75	0.552	14	75	0.304	14	75	0.856
19:00 - 20:00									
20:00 - 21:00									
21:00 - 22:00									
22:00 - 23:00									
23:00 - 24:00									
Total Rates:			4.113			4.310			8.423

This section displays the trip rate results based on the selected set of surveys and the selected count type (shown just above the table). It is split by three main columns, representing arrivals trips, departures trips, and total trips (arrivals plus departures). Within each of these main columns are three sub-columns. These display the number of survey days where count data is included (per time period), the average value of the selected trip rate calculation parameter (per time period), and the trip rate result (per time period). Total trip rates (the sum of the column) are also displayed at the foot of the table.

*To obtain a trip rate, the average (mean) trip rate parameter value (TRP) is first calculated for all selected survey days that have count data available for the stated time period. The average (mean) number of arrivals, departures or totals (whichever applies) is also calculated (COUNT) for all selected survey days that have count data available for the stated time period. Then, the average count is divided by the average trip rate parameter value, and multiplied by the stated calculation factor (shown just above the table and abbreviated here as FACT). So, the method is: COUNT/TRP*FACT. Trip rates are then rounded to 3 decimal places.*

Appendix 6

WU03EW - Location of usual residence and place of work by method of travel to work (MSOA)

ONS Crown Copyright Reserved [from Nomis on 17 December 2021]

population All usual residents aged 16 and over in employment the week before the census
 units Persons
 date 2011
 method of travel to work All categories: Method of travel to work (2001 specification)

usual residence

Place of work

E02001706 : Gateshead 025

County Durham	291
Darlington	7
Gateshead	1,157
Hartlepool	7
Middlesbrough	3
Newcastle upon Tyne	395
North Tyneside	85
Northumberland	62
Redcar and Cleveland	1
South Tyneside	81
Stockton-on-Tees	2
Sunderland	318

Place of work

E02001706 : Gateshead 025

E02001682 : Gateshead 001	1
E02001683 : Gateshead 002	4
E02001684 : Gateshead 003	44
E02001685 : Gateshead 004	1
E02001686 : Gateshead 005	17
E02001688 : Gateshead 007	213
E02001689 : Gateshead 008	27
E02001690 : Gateshead 009	89
E02001691 : Gateshead 010	7
E02001692 : Gateshead 011	5
E02001693 : Gateshead 012	8
E02001694 : Gateshead 013	2
E02001695 : Gateshead 014	12
E02001696 : Gateshead 015	12
E02001697 : Gateshead 016	76
E02001698 : Gateshead 017	12
E02001699 : Gateshead 018	4
E02001700 : Gateshead 019	16
E02001701 : Gateshead 020	33
E02001702 : Gateshead 021	16
E02001703 : Gateshead 022	2
E02001704 : Gateshead 023	22
E02001705 : Gateshead 024	1

E02001706 : Gateshead 025	146
E02001707 : Gateshead 026	239
E02006841 : Gateshead 027	139
E02006842 : Gateshead 028	9

Place of work

**E02001706 :
Gateshead 025**

E02004297 : County Durham 001	12
E02004290 : County Durham 002	14
E02004298 : County Durham 003	0
E02004299 : County Durham 004	7
E02004291 : County Durham 005	8
E02004300 : County Durham 006	3
E02004292 : County Durham 007	44
E02004301 : County Durham 008	1
E02004302 : County Durham 009	6
E02004303 : County Durham 010	12
E02004293 : County Durham 011	23
E02004304 : County Durham 012	4
E02004294 : County Durham 013	1
E02004305 : County Durham 014	2
E02004295 : County Durham 015	12
E02004320 : County Durham 016	3
E02004321 : County Durham 017	6
E02004322 : County Durham 018	0
E02004296 : County Durham 019	6
E02004306 : County Durham 020	1
E02004323 : County Durham 021	2
E02004308 : County Durham 022	5
E02004309 : County Durham 023	11
E02004307 : County Durham 024	2
E02004324 : County Durham 025	2
E02004310 : County Durham 026	0
E02004311 : County Durham 027	7
E02004312 : County Durham 028	9
E02004313 : County Durham 029	11
E02004314 : County Durham 030	25
E02004316 : County Durham 031	0
E02004325 : County Durham 032	1
E02004315 : County Durham 033	21
E02004326 : County Durham 034	5
E02004328 : County Durham 035	0
E02004327 : County Durham 036	0
E02004329 : County Durham 037	1
E02004317 : County Durham 038	1
E02004330 : County Durham 039	0
E02004331 : County Durham 040	0
E02004318 : County Durham 041	6
E02004348 : County Durham 042	0

E02004332 : County Durham 043	2
E02004319 : County Durham 044	0
E02004349 : County Durham 045	0
E02004350 : County Durham 046	1
E02004333 : County Durham 047	3
E02004334 : County Durham 048	2
E02004335 : County Durham 049	3
E02004336 : County Durham 050	0
E02004351 : County Durham 051	0
E02004337 : County Durham 052	0
E02004338 : County Durham 053	1
E02004339 : County Durham 054	1
E02004352 : County Durham 055	1
E02004353 : County Durham 056	0
E02004354 : County Durham 057	0
E02004355 : County Durham 058	0
E02004340 : County Durham 059	0
E02004341 : County Durham 060	0
E02004342 : County Durham 061	0
E02004343 : County Durham 062	0
E02004344 : County Durham 063	2
E02004345 : County Durham 064	1
E02004346 : County Durham 065	0
E02004347 : County Durham 066	0

Place of work

**E02001706 :
Gateshead 025**

E02001791 : Sunderland 001	1
E02001792 : Sunderland 002	0
E02001793 : Sunderland 003	0
E02001794 : Sunderland 004	0
E02001795 : Sunderland 005	9
E02001796 : Sunderland 006	5
E02001797 : Sunderland 007	55
E02001798 : Sunderland 008	6
E02001799 : Sunderland 009	18
E02001800 : Sunderland 010	35
E02001801 : Sunderland 011	5
E02001802 : Sunderland 012	4
E02001803 : Sunderland 013	20
E02001804 : Sunderland 014	3
E02001805 : Sunderland 015	0
E02001806 : Sunderland 016	2
E02001807 : Sunderland 017	51
E02001808 : Sunderland 018	1
E02001809 : Sunderland 019	41
E02001810 : Sunderland 020	3
E02001811 : Sunderland 021	1
E02001812 : Sunderland 022	2

E02001813 : Sunderland 023	2
E02001814 : Sunderland 024	1
E02001815 : Sunderland 025	7
E02001816 : Sunderland 026	0
E02001817 : Sunderland 027	1
E02001818 : Sunderland 028	0
E02001819 : Sunderland 029	13
E02001820 : Sunderland 030	3
E02001821 : Sunderland 031	0
E02001822 : Sunderland 032	2
E02001823 : Sunderland 033	2
E02001824 : Sunderland 034	1
E02001825 : Sunderland 035	23
E02001826 : Sunderland 036	1

Place of work

**E02001706 :
Gateshead 025**

E02001738 : North Tyneside 001	1
E02001739 : North Tyneside 002	0
E02001740 : North Tyneside 003	0
E02001741 : North Tyneside 004	3
E02001742 : North Tyneside 005	0
E02001743 : North Tyneside 006	1
E02001744 : North Tyneside 007	3
E02001745 : North Tyneside 008	10
E02001746 : North Tyneside 009	2
E02001747 : North Tyneside 010	0
E02001748 : North Tyneside 011	7
E02001749 : North Tyneside 012	2
E02001750 : North Tyneside 013	0
E02001751 : North Tyneside 014	1
E02001752 : North Tyneside 015	18
E02001753 : North Tyneside 016	0
E02001754 : North Tyneside 017	1
E02001755 : North Tyneside 018	4
E02001756 : North Tyneside 019	16
E02001757 : North Tyneside 020	0
E02001758 : North Tyneside 021	0
E02001759 : North Tyneside 022	5
E02001760 : North Tyneside 023	3
E02001761 : North Tyneside 024	0
E02001762 : North Tyneside 025	0
E02001763 : North Tyneside 026	1
E02001764 : North Tyneside 027	1
E02001765 : North Tyneside 028	3
E02001766 : North Tyneside 029	1
E02001767 : North Tyneside 030	2

Place of work**E02001706 :
Gateshead 025**

E02001708 : Newcastle upon Tyne 001	5
E02001709 : Newcastle upon Tyne 002	4
E02001710 : Newcastle upon Tyne 003	4
E02001711 : Newcastle upon Tyne 004	9
E02001712 : Newcastle upon Tyne 005	4
E02001713 : Newcastle upon Tyne 006	25
E02001714 : Newcastle upon Tyne 007	16
E02001715 : Newcastle upon Tyne 008	4
E02001718 : Newcastle upon Tyne 011	0
E02001719 : Newcastle upon Tyne 012	3
E02001720 : Newcastle upon Tyne 013	3
E02001721 : Newcastle upon Tyne 014	4
E02001722 : Newcastle upon Tyne 015	1
E02001723 : Newcastle upon Tyne 016	1
E02001724 : Newcastle upon Tyne 017	7
E02001725 : Newcastle upon Tyne 018	6
E02001726 : Newcastle upon Tyne 019	3
E02001727 : Newcastle upon Tyne 020	2
E02001728 : Newcastle upon Tyne 021	19
E02001729 : Newcastle upon Tyne 022	5
E02001730 : Newcastle upon Tyne 023	28
E02001731 : Newcastle upon Tyne 024	164
E02001732 : Newcastle upon Tyne 025	4
E02001733 : Newcastle upon Tyne 026	15
E02001734 : Newcastle upon Tyne 027	7
E02001735 : Newcastle upon Tyne 028	0
E02001736 : Newcastle upon Tyne 029	41
E02001737 : Newcastle upon Tyne 030	10
E02006893 : Newcastle upon Tyne 031	1

In order to protect against disclosure of personal information, records have been swapped between different geographic areas. Some counts will be affected, particularly small counts at the lowest geographies.

Place of work	E02001706 : Gateshead 025	Main Employment Area	Main	Alt Route	Alt Route	Main	Alt	Alt Route
			Route	1	2	Route	Route 1	2
E02001791 : Sunderland 001	1	Fulwell	B				0%	
E02001792 : Sunderland 002	0	Seaburn	B				0%	
E02001793 : Sunderland 003	0	Town End Farm	B				0%	
E02001794 : Sunderland 004	0	Marley Pots	B				0%	
E02001795 : Sunderland 005	9	Marley Pots	B				0%	
E02001796 : Sunderland 006	5	Monkwearmouth	B				0%	
E02001797 : Sunderland 007	55	Springwell	B				2%	
E02001798 : Sunderland 008	6	Hylton Castle	B				0%	
E02001799 : Sunderland 009	18	Concord	D				1%	
E02001800 : Sunderland 010	35	Albany	D				1%	
E02001801 : Sunderland 011	5	Pallion	B				0%	
E02001802 : Sunderland 012	4	Ford Estate	B				0%	
E02001803 : Sunderland 013	20	Sunderland	B				1%	
E02001804 : Sunderland 014	3	South Hylton	B				0%	
E02001805 : Sunderland 015	0	Pallion	B				0%	
E02001806 : Sunderland 016	2	Hendon	B				0%	
E02001807 : Sunderland 017	51	Washington	B				2%	
E02001808 : Sunderland 018	1	Barnes Park	B				0%	
E02001809 : Sunderland 019	41	Washington	B				2%	
E02001810 : Sunderland 020	3	Oxclose	B				0%	
E02001811 : Sunderland 021	1	Pennywell	B				0%	
E02001812 : Sunderland 022	2	Ashbrooke	B				0%	
E02001813 : Sunderland 023	2	Thorney Close	B				0%	
E02001814 : Sunderland 024	1	Grangeton	B				0%	
E02001815 : Sunderland 025	7	Mount Pleasant	B				0%	
E02001816 : Sunderland 026	0	Farringdon	50% - B	50% - D			0%	0%
E02001817 : Sunderland 027	1	Silksworth	50% - B	50% - D			0%	0%
E02001818 : Sunderland 028	0	Leechmeere	B				0%	
E02001819 : Sunderland 029	13	East Herrington	50% - B	50% - D			0%	0%
E02001820 : Sunderland 030	3	New Pershaw	D				0%	
E02001821 : Sunderland 031	0	Hall Farm	50% - B	50% - D			0%	0%
E02001822 : Sunderland 032	2	Newbottle	50% - D	50% - A			0%	0%
E02001823 : Sunderland 033	2	Fence Houses	33% - A	33% - W	33% - X		0%	0%
E02001824 : Sunderland 034	1	Houghton	D				0%	
E02001825 : Sunderland 035	23	Hetton	D				1%	
E02001826 : Sunderland 036	1	Moorsley	A				0%	
	2,409							

Place of work	E02001706 : Gateshead 025	Main Employment Area	Main	Alt Route	Alt Route	Main	Alt	Alt Route
			Route	1	2	Route	Route 1	2
E02001738 : North Tyneside 001	1	Whitley Bay	D				0%	
E02001739 : North Tyneside 002	0	Fordley	D				0%	
E02001740 : North Tyneside 003	0	Whitley Bay	D				0%	
E02001741 : North Tyneside 004	3	Seaton Burn	C				0%	
E02001742 : North Tyneside 005	0	Monkseaton	D				0%	
E02001743 : North Tyneside 006	1	Whitley Bay	D				0%	
E02001744 : North Tyneside 007	3	Backworth	D				0%	
E02001745 : North Tyneside 008	10	Killingworth	D				0%	
E02001746 : North Tyneside 009	2	New York	D				0%	
E02001747 : North Tyneside 010	0	Cullercoats	D				0%	
E02001748 : North Tyneside 011	7	Shiremoor	D				0%	
E02001749 : North Tyneside 012	2	Killingworth	D				0%	
E02001750 : North Tyneside 013	0	Monkseaton	D				0%	
E02001751 : North Tyneside 014	1	Forest Hall	D				0%	
E02001752 : North Tyneside 015	18	New York	D				1%	
E02001753 : North Tyneside 016	0	Tynemouth	D				0%	
E02001754 : North Tyneside 017	1	Tynemouth	D				0%	
E02001755 : North Tyneside 018	4	Benton	Y				0%	
E02001756 : North Tyneside 019	16	Longbenton	Y				1%	
E02001757 : North Tyneside 020	0	North Shields	D				0%	
E02001758 : North Tyneside 021	0	Holystone	D				0%	
E02001759 : North Tyneside 022	5	North Shields	D				0%	
E02001760 : North Tyneside 023	3	North Shields	D				0%	
E02001761 : North Tyneside 024	0	Wallsend	D				0%	
E02001762 : North Tyneside 025	0	Wallsend	D				0%	
E02001763 : North Tyneside 026	1	Howdon	D				0%	
E02001764 : North Tyneside 027	1	Percy Main	D				0%	
E02001765 : North Tyneside 028	3	Howdon	D				0%	
E02001766 : North Tyneside 029	1	Wallsend	D				0%	
E02001767 : North Tyneside 030	2	Wallsend	D				0%	
	2,409							

Place of work	E02001706 : Gateshead 025	Main Employment Area	Main	Alt Route	Alt Route	Main	Alt	Alt Route
			Route	1	2	Route	Route 1	2
E02001708 : Newcastle upon Tyne 001	5	Dinnington	C				0%	
E02001709 : Newcastle upon Tyne 002	4	North Gosforth	C				0%	
E02001710 : Newcastle upon Tyne 003	4	Coxlodge	E				0%	
E02001711 : Newcastle upon Tyne 004	9	Callerton	C				0%	
E02001712 : Newcastle upon Tyne 005	4	South Gosforth	Y				0%	
E02001713 : Newcastle upon Tyne 006	25	Gosforth	Y				1%	
E02001714 : Newcastle upon Tyne 007	16	High Heaton	Y				1%	
E02001715 : Newcastle upon Tyne 008	4	Kenton	C				0%	
E02001718 : Newcastle upon Tyne 011	0	Blakelaw	C				0%	
E02001719 : Newcastle upon Tyne 012	3	High Heaton	Y				0%	
E02001720 : Newcastle upon Tyne 013	3	Jesmond	Y				0%	
E02001721 : Newcastle upon Tyne 014	4	Throckley	C				0%	
E02001722 : Newcastle upon Tyne 015	1	Westerhope	C				0%	
E02001723 : Newcastle upon Tyne 016	1	Cowgate	C				0%	
E02001724 : Newcastle upon Tyne 017	7	Jesmond	Y				0%	
E02001725 : Newcastle upon Tyne 018	6	Heaton	50% - C	50% - Y			0%	0%
E02001726 : Newcastle upon Tyne 019	3	Ferham	50% - C	50% - E			0%	0%
E02001727 : Newcastle upon Tyne 020	2	Wallsend	D				0%	
E02001728 : Newcastle upon Tyne 021	19	Lemington	C				1%	
E02001729 : Newcastle upon Tyne 022	5	Arthur's Hill	E				0%	
E02001730 : Newcastle upon Tyne 023	28	Shieldfield	50% - Y	50% - E			1%	1%
E02001731 : Newcastle upon Tyne 024	164	Newcastle	E				7%	
E02001732 : Newcastle upon Tyne 025	4	Leemington	C				0%	
E02001733 : Newcastle upon Tyne 026	15	Byker	E				1%	
E02001734 : Newcastle upon Tyne 027	7	Elswick	E				0%	
E02001735 : Newcastle upon Tyne 028	0	Walker	50% - D	50% - Y			0%	0%
E02001736 : Newcastle upon Tyne 029	41	Elswick	E				2%	
E02001737 : Newcastle upon Tyne 030	10	Walker	50% - D	50% - Y			0%	0%
E02006893 : Newcastle upon Tyne 031	1	Westerhope	C				0%	
	2,409							

In order to protect against disclosure of personal information, records have been swapped between different geographic areas. Some counts will be affected, particularly small counts at the lowest geographies.

Appendix 7

2022 Observed Traffic - AM (08:00-09:00)

This diagram shows the vehicle trips (PCUs) observed in the 2022 surveys for the AM peak.

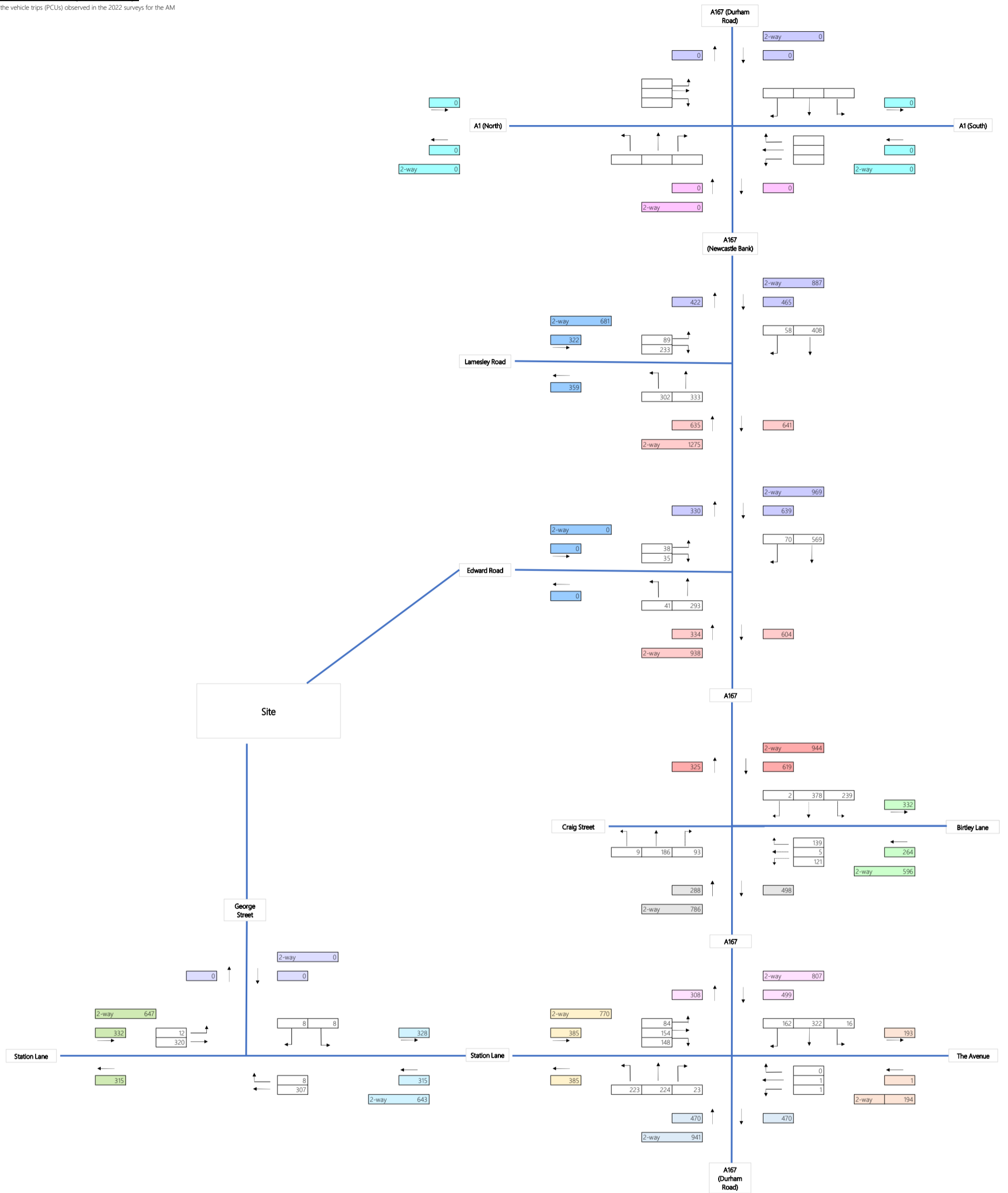

2022 Observed Traffic - PM (17:00-18:00)

This diagram shows the vehicle trips (PCUs) observed in the 2022 surveys for the PM peak.

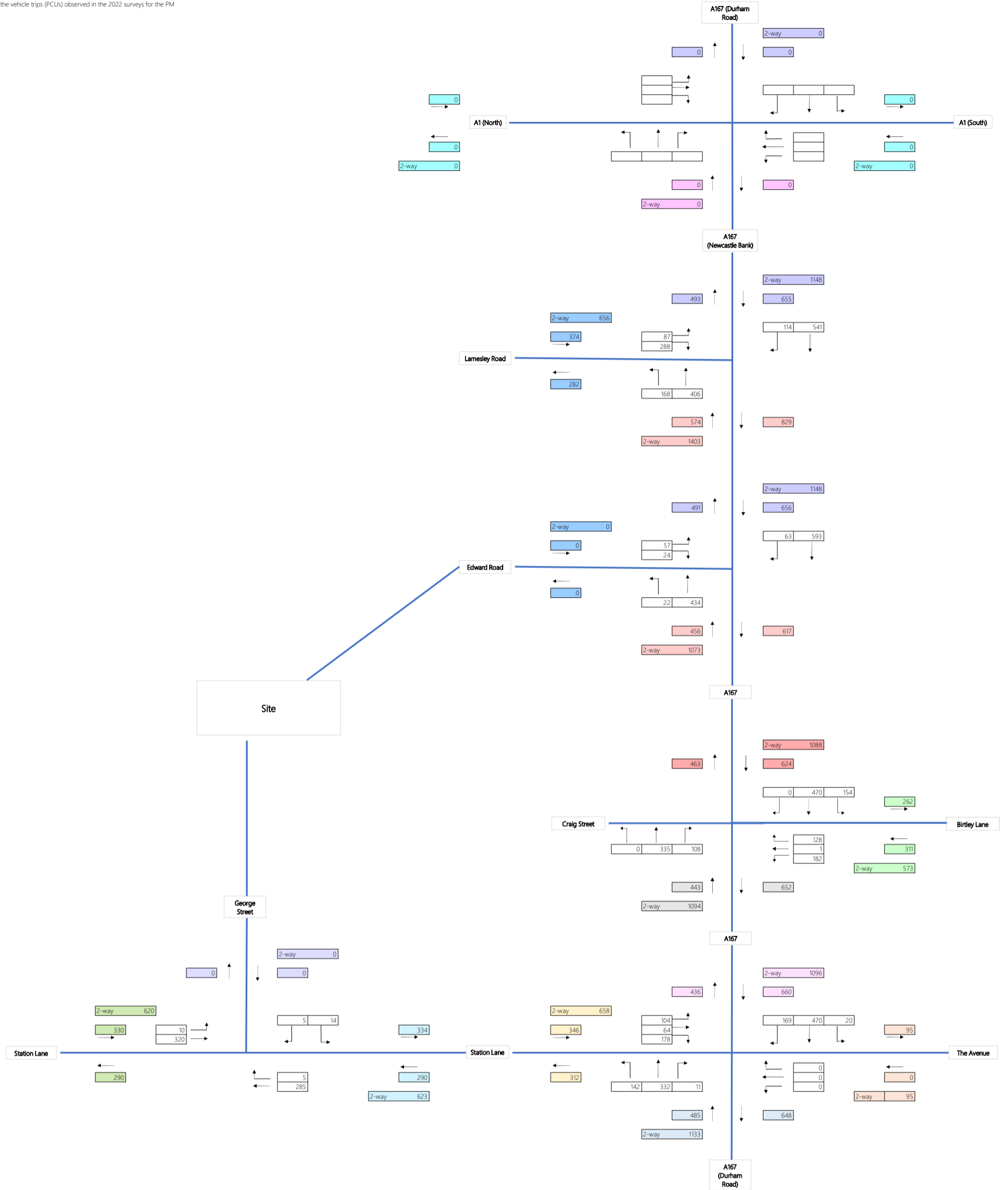

Appendix 8

2028 Baseline Traffic - AM (08:00-09:00)

This diagram shows the vehicle trips observed in the 2022 surveys for the AM peak, growthed using TEMPro to predict 2028 vehicle movements.

TEMPro growth rate: 1.0535

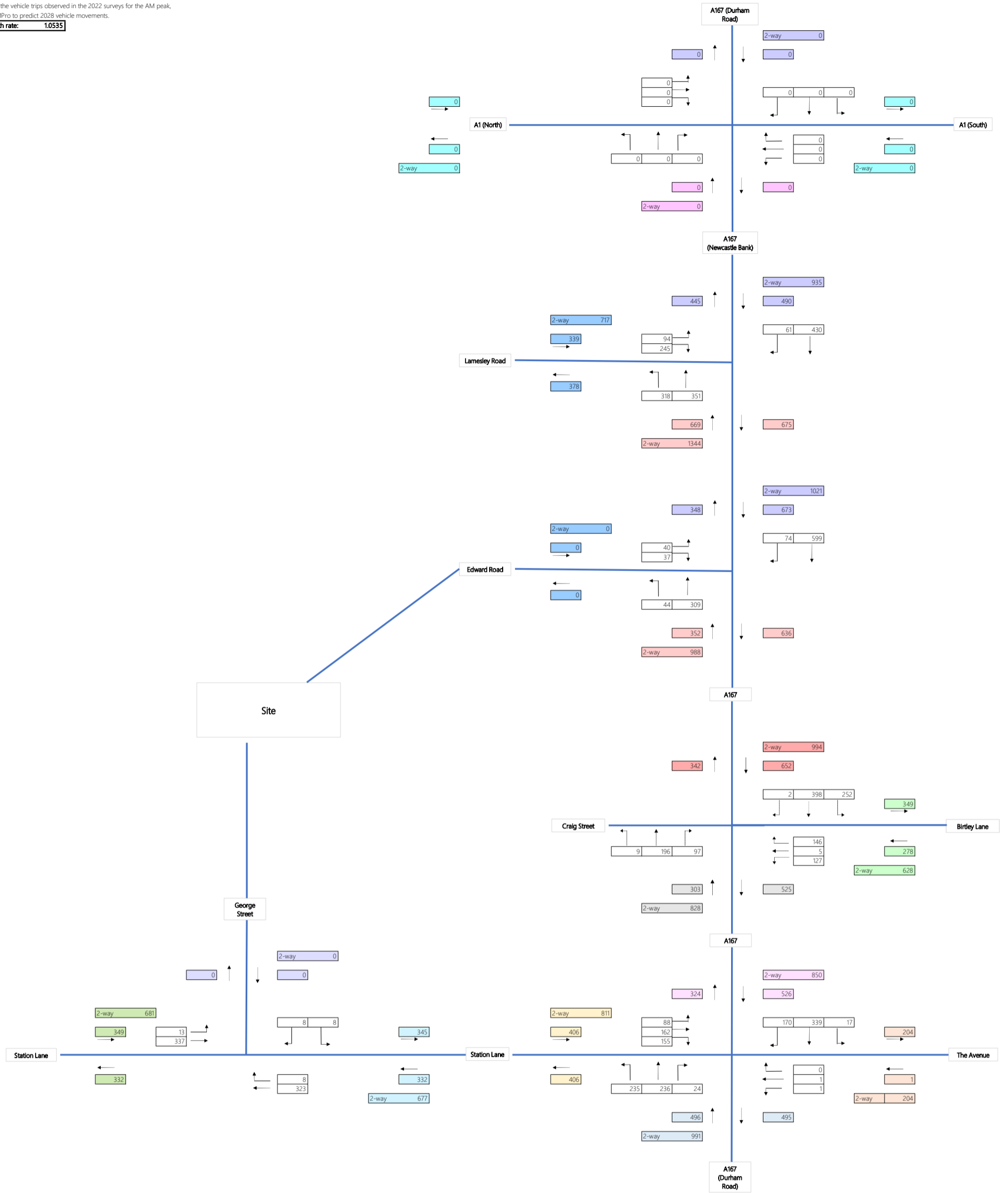

2028 Baseline Traffic - PM (17:00-18:00)

This diagram shows the vehicle trips observed in the 2022 surveys for the PM peak, growthed using TEMPro to predict 2028 vehicle movements.

TEMPro growth rate: 1.0511

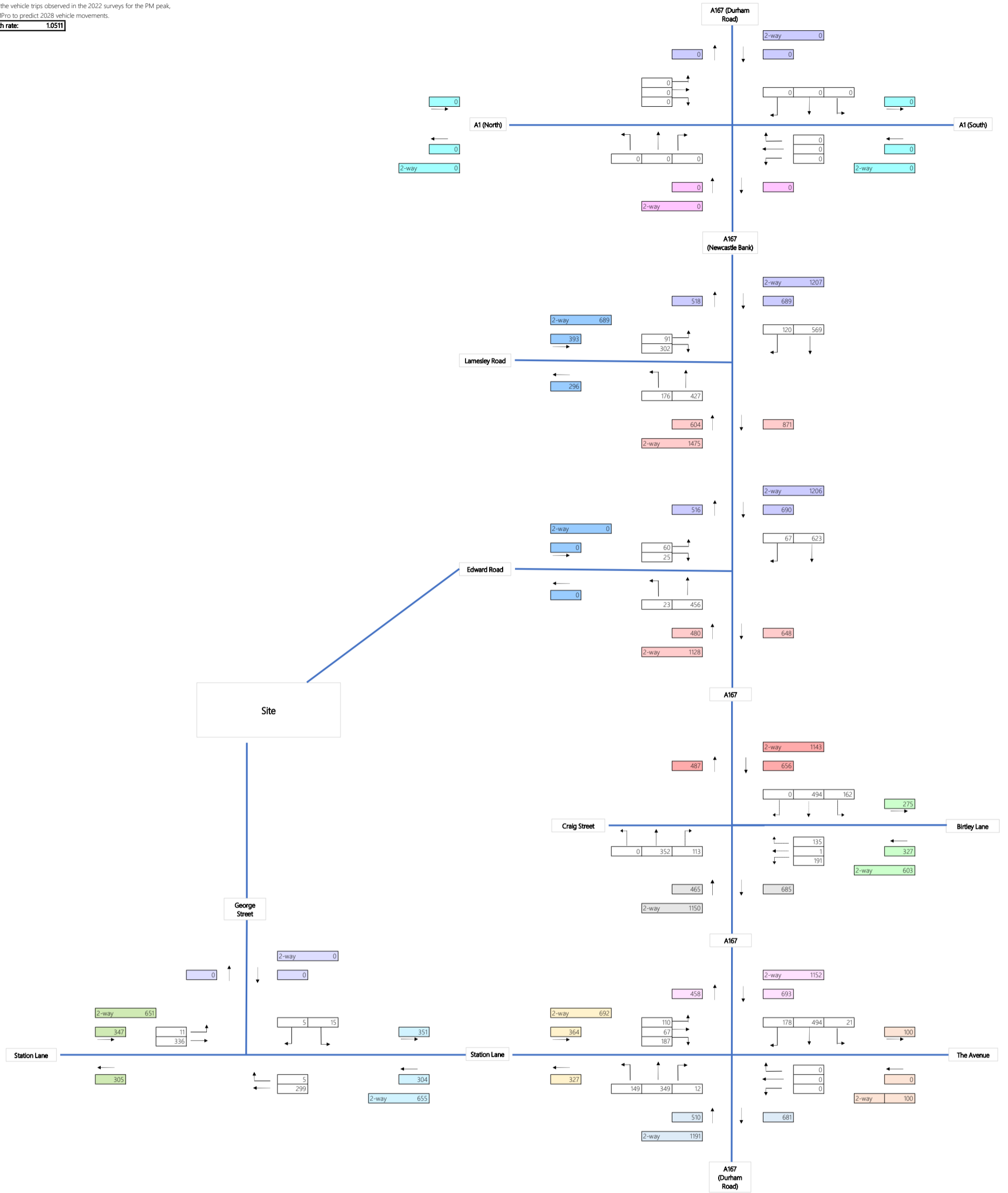

Appendix 9

Development Traffic Flows - AM (08:00-09:00)

This diagram predicts the number of vehicles generated during the AM peak by the site using a TRICS analysis and distributing them using a 2011 Census routing exercise.

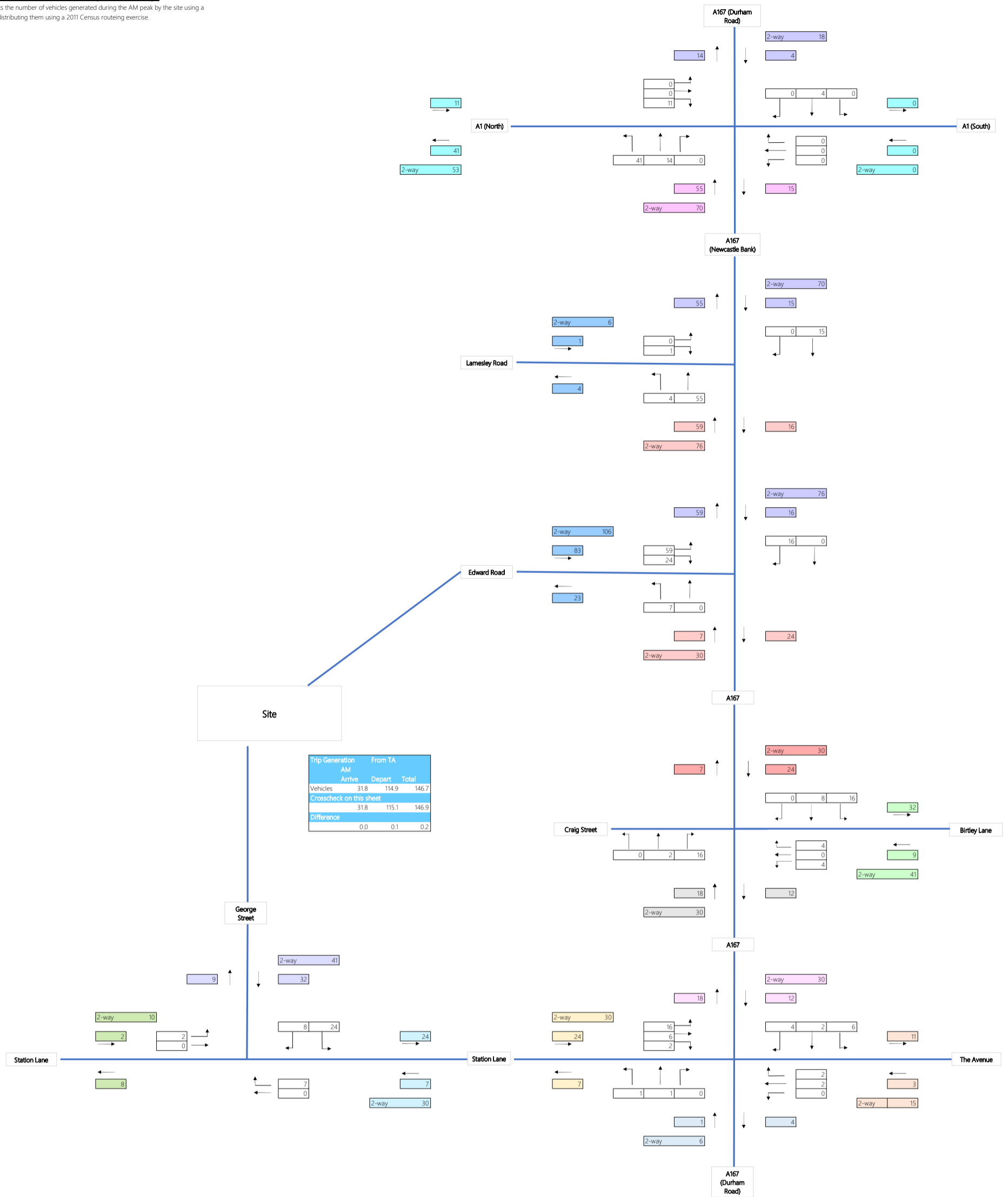

Development Traffic Flows - PM (17:00-18:00)

This diagram predicts the number of vehicles generated during the PM peak by the site using a TRICS analysis and distributing them using a 2011 Census routing exercise.

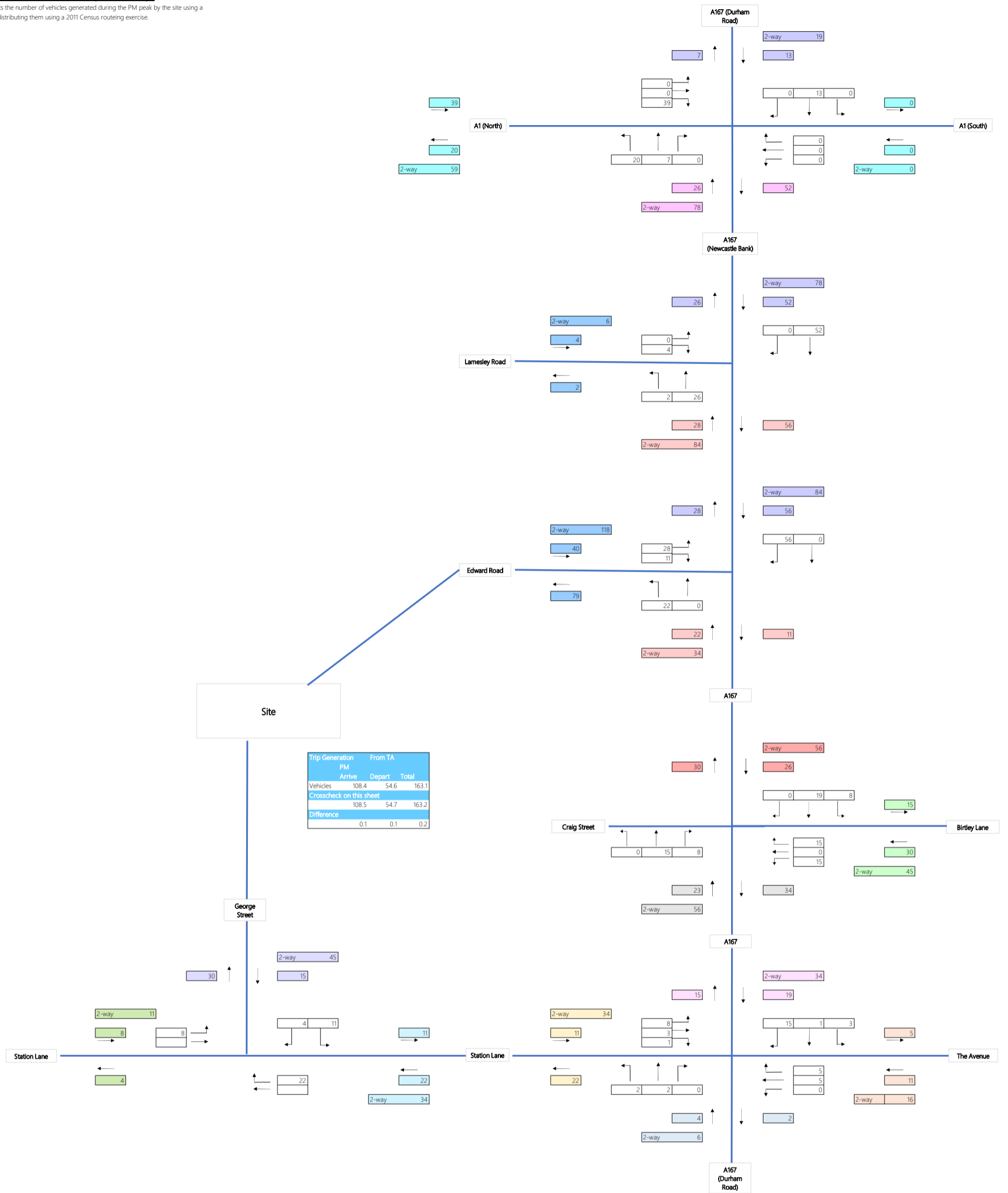

Appendix 10

Total Committed Development Traffic Flows - PM Peak

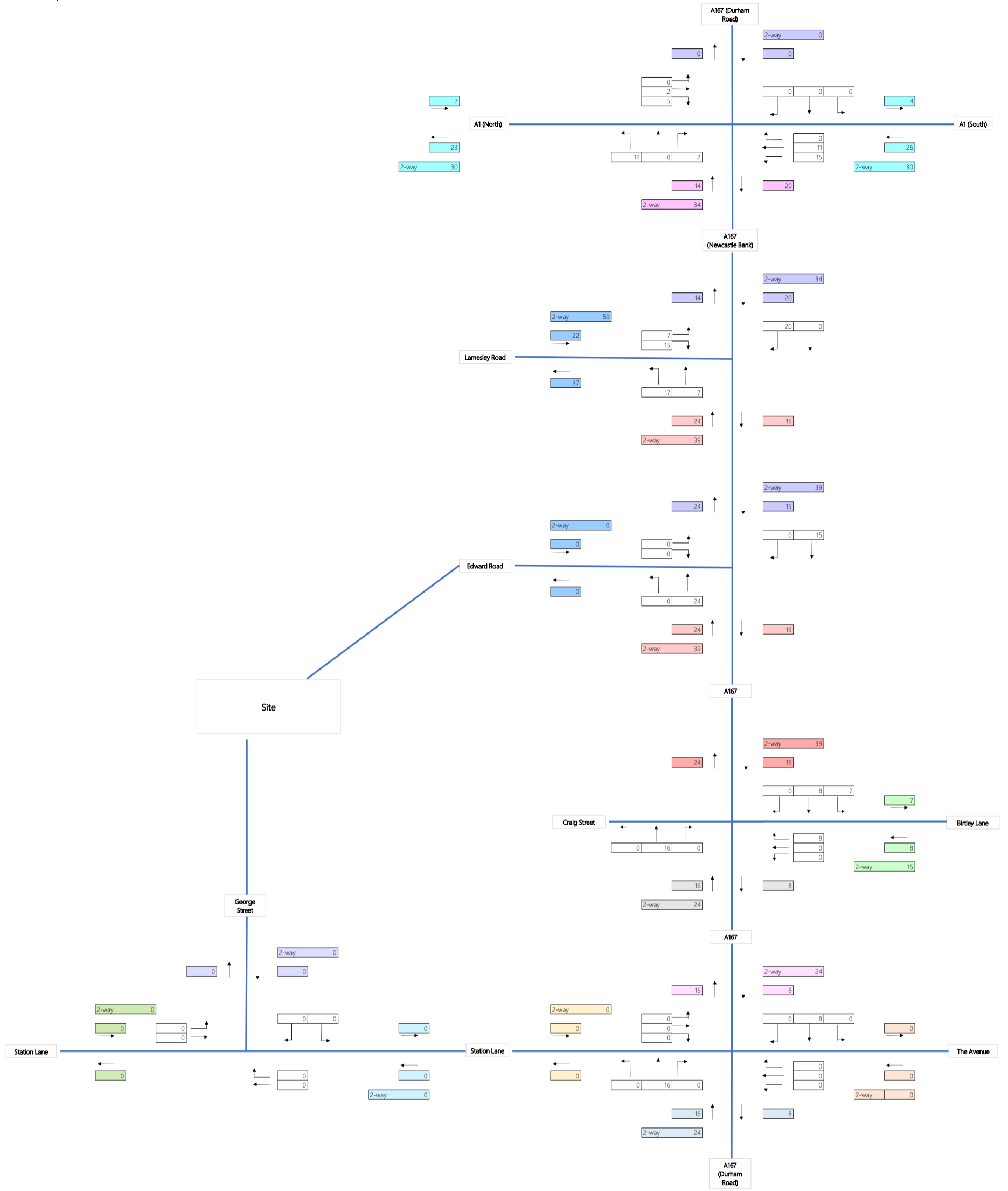

Appendix 11

2028 Baseline + Committed Developments + Development Traffic - AM (08:00-09:00)

This diagram adds the committed developments and development traffic and the 2028 baseline, for the AM peak.

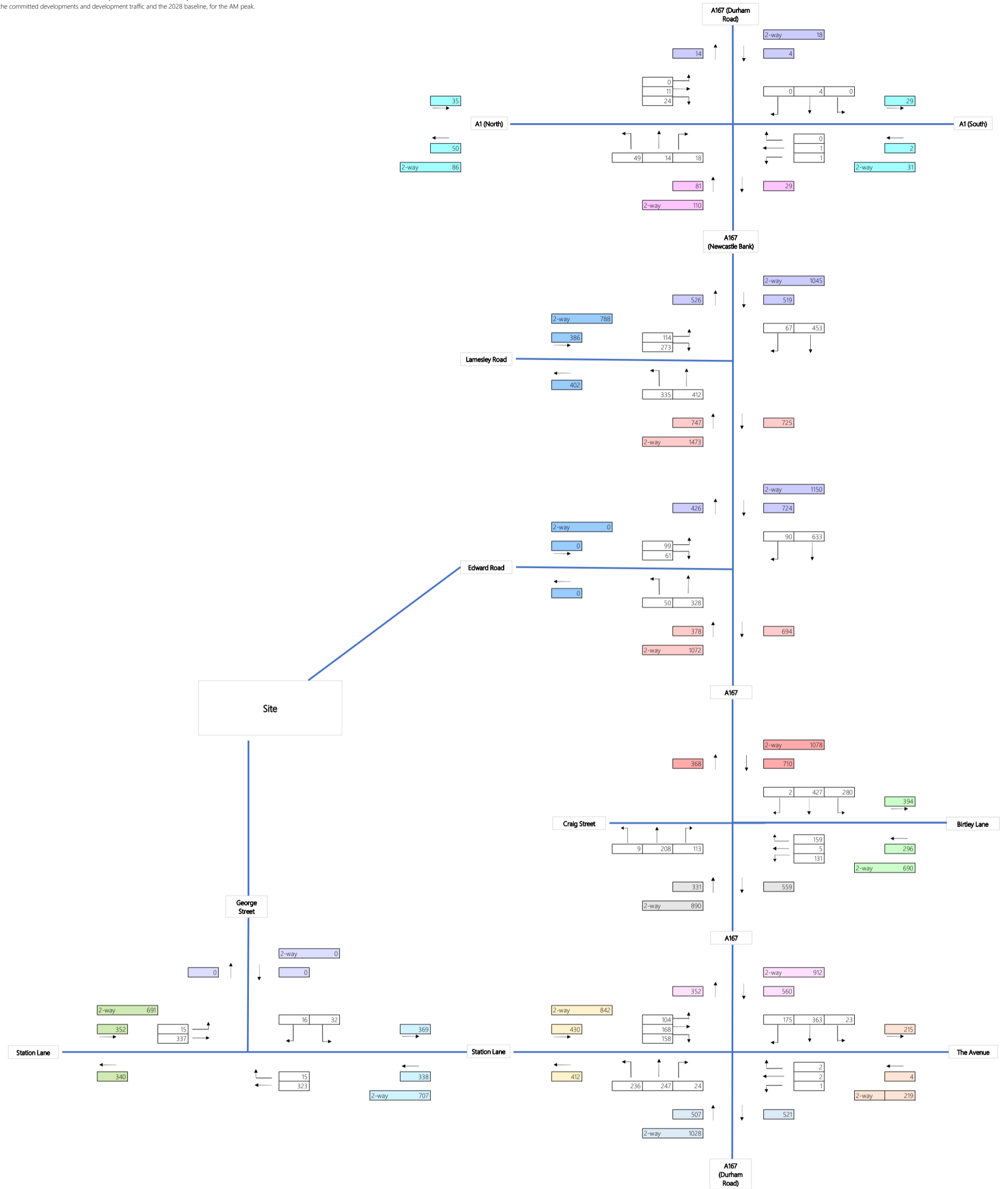

2028 Baseline + Committed Developments + Development Traffic - PM (17:00-18:00)

This diagram adds the committed developments and development traffic and the 2028 baseline, for the PM peak.

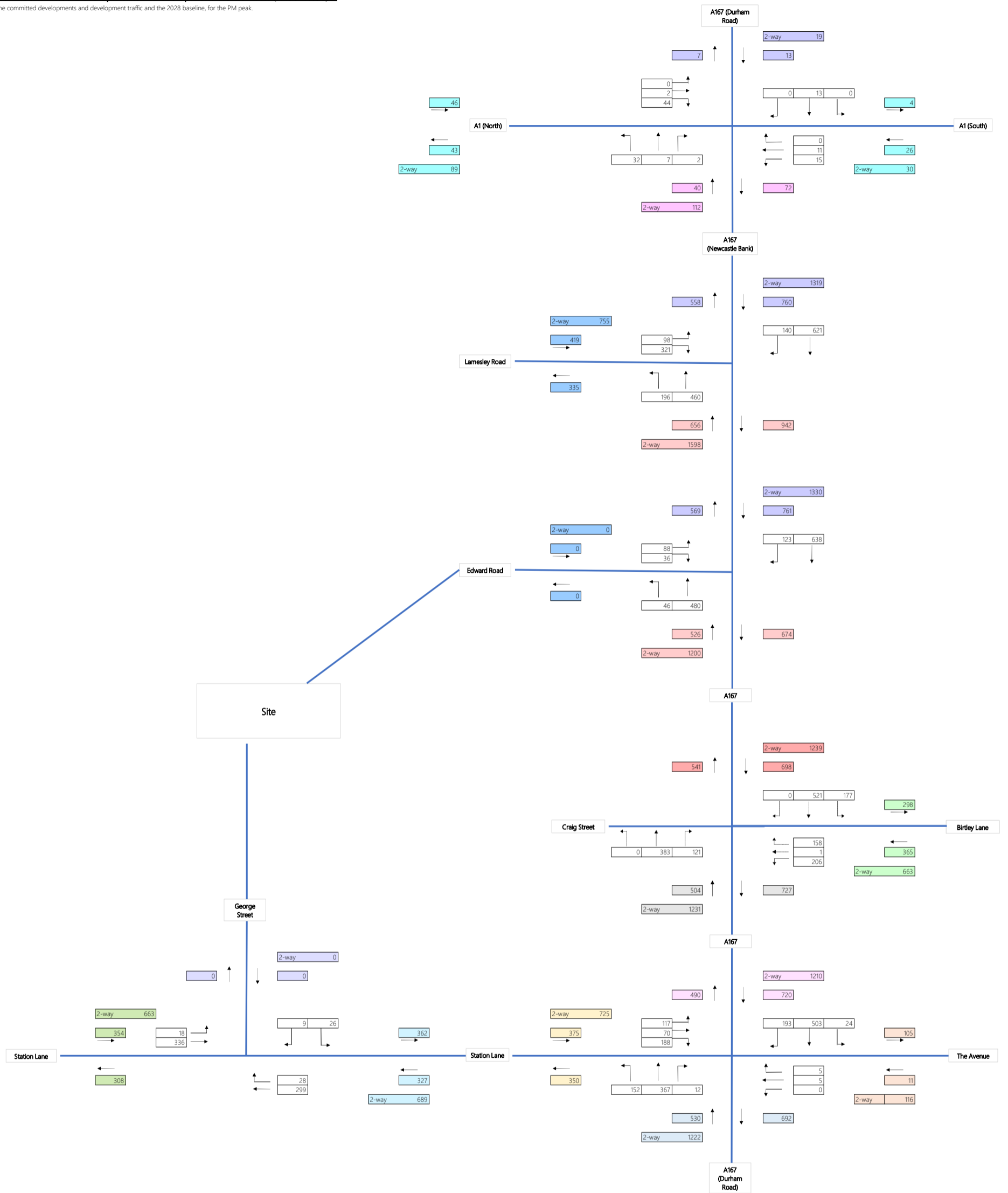

Appendix 12

Junctions 9
PICADY 9 - Priority Intersection Module
Version: 9.5.1.7462 © Copyright TRL Limited, 2019
For sales and distribution information, program advice and maintenance, contact TRL: +44 (0)1344 379777 software@trl.co.uk www.trlsoftware.co.uk
The users of this computer program for the solution of an engineering problem are in no way relieved of their responsibility for the correctness of the solution

Filename: Import of A167-Lamesley Lane.j9
Path: P:\22 Jobs\024-N Former BAE site, Birtley, Gateshead\Technical Assessments\Junctions9
Report generation date: 17/06/2022 16:11:26

- »2022 Baseline, AM
- »2022 Baseline, PM
- »2028 Baseline, AM
- »2028 Baseline, PM
- »2028 Baseline + CD + Dev, AM
- »2028 Baseline + CD + Dev, PM

Summary of junction performance

	AM						PM					
	Set ID	Queue (PCU)	Delay (s)	RFC	LOS	Network Residual Capacity	Set ID	Queue (PCU)	Delay (s)	RFC	LOS	Network Residual Capacity
2022 Baseline												
Stream B-C	D1	0.4	16.42	0.26	C	4 % [Stream B-A]	D2	3.7	148.39	0.85	F	-15 % [Stream B-A]
Stream B-A		2.0	28.60	0.63	D			8.1	98.71	0.92	F	
Stream C-B		0.2	11.34	0.14	B			0.4	12.78	0.26	B	
2028 Baseline												
Stream B-C	D3	0.5	19.26	0.30	C	0 % [Stream B-A]	D4	6.6	240.60	1.01	F	-19 % [Stream B-A]
Stream B-A		2.5	34.59	0.68	D			14.5	160.74	1.01	F	
Stream C-B		0.2	11.68	0.15	B			0.5	13.30	0.28	B	
2028 Baseline + CD + Dev												
Stream B-C	D5	1.5	45.94	0.56	E	-10 % [Stream B-A]	D6	11.5	411.92	1.19	F	-25 % [Stream B-A]
Stream B-A		5.2	67.00	0.84	F			32.7	325.09	1.17	F	
Stream C-B		0.3	12.54	0.17	B			0.6	14.83	0.33	B	

Values shown are the highest values encountered over all time segments. Delay is the maximum value of average delay per arriving vehicle. Network Residual Capacity indicates the amount by which network flow could be increased before a user-definable threshold (see Analysis Options) is met.

File summary

File Description

Title	
Location	
Site number	
Date	27/04/2022
Version	
Status	(new file)
Identifier	
Client	
Jobnumber	
Enumerator	mtp\awreford
Description	

Units

Distance units	Speed units	Traffic units input	Traffic units results	Flow units	Average delay units	Total delay units	Rate of delay units
m	kph	PCU	PCU	perHour	s	-Min	perMin

Analysis Options

Vehicle length (m)	Calculate Queue Percentiles	Calculate detailed queueing delay	Calculate residual capacity	Residual capacity criteria type	RFC Threshold	Average Delay threshold (s)	Queue threshold (PCU)
5.75			✓	Delay	0.85	36.00	20.00

Demand Set Summary

ID	Scenario name	Time Period name	Traffic profile type	Start time (HH:mm)	Finish time (HH:mm)	Time segment length (min)	Run automatically
D1	2022 Baseline	AM	ONE HOUR	07:45	09:15	15	✓
D2	2022 Baseline	PM	ONE HOUR	16:45	18:15	15	✓
D3	2028 Baseline	AM	ONE HOUR	07:45	09:15	15	✓
D4	2028 Baseline	PM	ONE HOUR	16:45	18:15	15	✓
D5	2028 Baseline + CD + Dev	AM	ONE HOUR	07:45	09:15	15	✓
D6	2028 Baseline + CD + Dev	PM	ONE HOUR	16:45	18:15	15	✓

Analysis Set Details

ID	Include in report	Network flow scaling factor (%)	Network capacity scaling factor (%)
A1	✓	100.000	100.000

2022 Baseline, AM

Data Errors and Warnings

No errors or warnings

Junction Network

Junctions

Junction	Name	Junction type	Major road direction	Use circulating lanes	Junction Delay (s)	Junction LOS
1	untitled	T-Junction	Two-way		6.17	A

Junction Network Options

Driving side	Lighting	Network residual capacity (%)	First arm reaching threshold
Left	Normal/unknown	4	Stream B-A

Arms

Arms

Arm	Name	Description	Arm type
A	A167 South		Major
B	Lamesley Lane		Minor
C	A167 North		Major

Major Arm Geometry

Arm	Width of carriageway (m)	Has kerbed central reserve	Width of kerbed central reserve (m)	Has right turn bay	Width for right turn (m)	Visibility for right turn (m)	Blocks?	Blocking queue (PCU)
A167 North	7.04	✓	2.62	✓	2.56	62.5		-

Geometries for Arm C are measured opposite Arm B. Geometries for Arm A (if relevant) are measured opposite Arm D.

Minor Arm Geometry

Arm	Minor arm type	Width at give-way (m)	Width at 5m (m)	Width at 10m (m)	Width at 15m (m)	Width at 20m (m)	Estimate flare length	Flare length (PCU)	Visibility to left (m)	Visibility to right (m)
Lamesley Lane	One lane plus flare	10.00	8.05	6.32	4.69	3.41	✓	2.00	64	69

Slope / Intercept / Capacity

Priority Intersection Slopes and Intercepts

Stream	Intercept (PCU/hr)	Slope for A-B	Slope for A-C	Slope for C-A	Slope for C-B
B-A	648	0.106	0.269	0.169	0.384
B-C	653	0.095	0.241	-	-
C-B	634	0.235	0.235	-	-

The slopes and intercepts shown above do NOT include any corrections or adjustments.

Streams may be combined, in which case capacity will be adjusted.

Values are shown for the first time segment only; they may differ for subsequent time segments.

Traffic Demand

Demand Set Details

ID	Scenario name	Time Period name	Traffic profile type	Start time (HH:mm)	Finish time (HH:mm)	Time segment length (min)	Run automatically
D1	2022 Baseline	AM	ONE HOUR	07:45	09:15	15	✓

Vehicle mix varies over turn	Vehicle mix varies over entry	Vehicle mix source	PCU Factor for a HV (PCU)
✓	✓	HV Percentages	2.00

Demand overview (Traffic)

Arm	Linked arm	Profile type	Use O-D data	Average Demand (PCU/hr)	Scaling Factor (%)
A167 South		ONE HOUR	✓	635	100.000
Lamesley Lane		ONE HOUR	✓	322	100.000
A167 North		ONE HOUR	✓	466	100.000

Origin-Destination Data

Demand (PCU/hr)

		To		
		A167 South	Lamesley Lane	A167 North
From	A167 South	0	302	333
	Lamesley Lane	233	0	89
	A167 North	408	58	0

Vehicle Mix

Heavy Vehicle Percentages

		To		
		A167 South	Lamesley Lane	A167 North
From	A167 South	0	25	20
	Lamesley Lane	22	0	27
	A167 North	18	28	0

Results

Results Summary for whole modelled period

Stream	Max RFC	Max Delay (s)	Max Queue (PCU)	Max LOS	Average Demand (PCU/hr)	Total Junction Arrivals (PCU)
B-C	0.26	16.42	0.4	C	82	123
B-A	0.63	28.60	2.0	D	214	321
C-A					374	562
C-B	0.14	11.34	0.2	B	53	80
A-B					277	416
A-C					306	458

Main Results for each time segment

07:45 - 08:00

Stream	Total Demand (PCU/hr)	Junction Arrivals (PCU)	Capacity (PCU/hr)	RFC	Throughput (PCU/hr)	Start queue (PCU)	End queue (PCU)	Delay (s)	Unsignalised level of service
B-C	67	17	509	0.132	66	0.0	0.2	10.319	B
B-A	175	44	487	0.360	173	0.0	0.7	13.861	B
C-A	307	77			307				
C-B	44	11	522	0.084	43	0.0	0.1	9.613	A
A-B	227	57			227				
A-C	251	63			251				

08:00 - 08:15

Stream	Total Demand (PCU/hr)	Junction Arrivals (PCU)	Capacity (PCU/hr)	RFC	Throughput (PCU/hr)	Start queue (PCU)	End queue (PCU)	Delay (s)	Unsignalised level of service
B-C	80	20	465	0.172	80	0.2	0.3	11.855	B
B-A	209	52	455	0.460	208	0.7	1.0	17.694	C
C-A	367	92			367				
C-B	52	13	500	0.104	52	0.1	0.1	10.276	B
A-B	271	68			271				
A-C	299	75			299				

08:15 - 08:30

Stream	Total Demand (PCU/hr)	Junction Arrivals (PCU)	Capacity (PCU/hr)	RFC	Throughput (PCU/hr)	Start queue (PCU)	End queue (PCU)	Delay (s)	Unsignalised level of service
B-C	98	24	381	0.257	97	0.3	0.4	16.085	C
B-A	257	64	409	0.627	253	1.0	1.9	27.474	D
C-A	449	112			449				
C-B	64	16	470	0.136	64	0.1	0.2	11.326	B
A-B	333	83			333				
A-C	367	92			367				

08:30 - 08:45

Stream	Total Demand (PCU/hr)	Junction Arrivals (PCU)	Capacity (PCU/hr)	RFC	Throughput (PCU/hr)	Start queue (PCU)	End queue (PCU)	Delay (s)	Unsignalised level of service
B-C	98	24	376	0.260	98	0.4	0.4	16.416	C
B-A	257	64	409	0.627	256	1.9	2.0	28.596	D
C-A	449	112			449				
C-B	64	16	470	0.136	64	0.2	0.2	11.337	B
A-B	333	83			333				
A-C	367	92			367				

08:45 - 09:00

Stream	Total Demand (PCU/hr)	Junction Arrivals (PCU)	Capacity (PCU/hr)	RFC	Throughput (PCU/hr)	Start queue (PCU)	End queue (PCU)	Delay (s)	Unsignalised level of service
B-C	80	20	458	0.175	81	0.4	0.3	12.142	B
B-A	209	52	446	0.469	213	2.0	1.1	19.083	C
C-A	367	92			367				
C-B	52	13	500	0.104	52	0.2	0.2	10.289	B
A-B	271	68			271				
A-C	299	75			299				

09:00 - 09:15

Stream	Total Demand (PCU/hr)	Junction Arrivals (PCU)	Capacity (PCU/hr)	RFC	Throughput (PCU/hr)	Start queue (PCU)	End queue (PCU)	Delay (s)	Unsignalised level of service
B-C	67	17	506	0.132	67	0.3	0.2	10.430	B
B-A	175	44	487	0.360	177	1.1	0.7	14.249	B
C-A	307	77			307				
C-B	44	11	522	0.084	44	0.2	0.1	9.635	A
A-B	227	57			227				
A-C	251	63			251				

2022 Baseline, PM

Data Errors and Warnings

No errors or warnings

Junction Network

Junctions

Junction	Name	Junction type	Major road direction	Use circulating lanes	Junction Delay (s)	Junction LOS
1	untitled	T-Junction	Two-way		26.68	D

Junction Network Options

Driving side	Lighting	Network residual capacity (%)	First arm reaching threshold
Left	Normal/unknown	-15	Stream B-A

Traffic Demand

Demand Set Details

ID	Scenario name	Time Period name	Traffic profile type	Start time (HH:mm)	Finish time (HH:mm)	Time segment length (min)	Run automatically
D2	2022 Baseline	PM	ONE HOUR	16:45	18:15	15	✓

Vehicle mix varies over turn	Vehicle mix varies over entry	Vehicle mix source	PCU Factor for a HV (PCU)
✓	✓	HV Percentages	2.00

Demand overview (Traffic)

Arm	Linked arm	Profile type	Use O-D data	Average Demand (PCU/hr)	Scaling Factor (%)
A167 South		ONE HOUR	✓	574	100.000
Lamesley Lane		ONE HOUR	✓	375	100.000
A167 North		ONE HOUR	✓	655	100.000

Origin-Destination Data

Demand (PCU/hr)

		To		
		A167 South	Lamesley Lane	A167 North
From	A167 South	0	168	406
	Lamesley Lane	288	0	87
	A167 North	541	114	0

Vehicle Mix

Heavy Vehicle Percentages

		To		
		A167 South	Lamesley Lane	A167 North
From	A167 South	0	25	20
	Lamesley Lane	22	0	27
	A167 North	18	28	0

Results

Results Summary for whole modelled period

Stream	Max RFC	Max Delay (s)	Max Queue (PCU)	Max LOS	Average Demand (PCU/hr)	Total Junction Arrivals (PCU)
B-C	0.85	148.39	3.7	F	80	120
B-A	0.92	98.71	8.1	F	264	396
C-A					496	745
C-B	0.26	12.78	0.4	B	105	157
A-B					154	231
A-C					373	559

Main Results for each time segment

16:45 - 17:00

Stream	Total Demand (PCU/hr)	Junction Arrivals (PCU)	Capacity (PCU/hr)	RFC	Throughput (PCU/hr)	Start queue (PCU)	End queue (PCU)	Delay (s)	Unsignalised level of service
B-C	65	16	461	0.142	65	0.0	0.2	11.498	B
B-A	217	54	445	0.487	212	0.0	1.1	18.559	C
C-A	407	102			407				
C-B	86	21	533	0.161	85	0.0	0.2	10.264	B
A-B	126	32			126				
A-C	306	76			306				

17:00 - 17:15

Stream	Total Demand (PCU/hr)	Junction Arrivals (PCU)	Capacity (PCU/hr)	RFC	Throughput (PCU/hr)	Start queue (PCU)	End queue (PCU)	Delay (s)	Unsignalised level of service
B-C	78	20	378	0.207	78	0.2	0.3	15.199	C
B-A	259	65	405	0.639	255	1.1	2.0	28.621	D
C-A	486	122			486				
C-B	102	26	513	0.200	102	0.2	0.3	11.202	B
A-B	151	38			151				
A-C	365	91			365				

17:15 - 17:30

Stream	Total Demand (PCU/hr)	Junction Arrivals (PCU)	Capacity (PCU/hr)	RFC	Throughput (PCU/hr)	Start queue (PCU)	End queue (PCU)	Delay (s)	Unsignalised level of service
B-C	96	24	164	0.584	91	0.3	1.5	59.234	F
B-A	317	79	348	0.911	299	2.0	6.5	71.925	F
C-A	596	149			596				
C-B	126	31	486	0.258	125	0.3	0.4	12.746	B
A-B	185	46			185				
A-C	447	112			447				

17:30 - 17:45

Stream	Total Demand (PCU/hr)	Junction Arrivals (PCU)	Capacity (PCU/hr)	RFC	Throughput (PCU/hr)	Start queue (PCU)	End queue (PCU)	Delay (s)	Unsignalised level of service
B-C	96	24	112	0.855	87	1.5	3.7	148.392	F
B-A	317	79	346	0.915	311	6.5	8.1	98.715	F
C-A	596	149			596				
C-B	126	31	486	0.258	126	0.4	0.4	12.781	B
A-B	185	46			185				
A-C	447	112			447				

17:45 - 18:00

Stream	Total Demand (PCU/hr)	Junction Arrivals (PCU)	Capacity (PCU/hr)	RFC	Throughput (PCU/hr)	Start queue (PCU)	End queue (PCU)	Delay (s)	Unsignalised level of service
B-C	78	20	338	0.231	91	3.7	0.4	19.441	C
B-A	259	65	402	0.643	282	8.1	2.4	41.436	E
C-A	486	122			486				
C-B	102	26	513	0.200	103	0.4	0.3	11.246	B
A-B	151	38			151				
A-C	365	91			365				

18:00 - 18:15

Stream	Total Demand (PCU/hr)	Junction Arrivals (PCU)	Capacity (PCU/hr)	RFC	Throughput (PCU/hr)	Start queue (PCU)	End queue (PCU)	Delay (s)	Unsignalised level of service
B-C	65	16	453	0.145	66	0.4	0.2	11.843	B
B-A	217	54	445	0.488	222	2.4	1.2	20.098	C
C-A	407	102			407				
C-B	86	21	533	0.161	86	0.3	0.2	10.322	B
A-B	126	32			126				
A-C	306	76			306				

2028 Baseline, AM

Data Errors and Warnings

No errors or warnings

Junction Network

Junctions

Junction	Name	Junction type	Major road direction	Use circulating lanes	Junction Delay (s)	Junction LOS
1	untitled	T-Junction	Two-way		7.34	A

Junction Network Options

Driving side	Lighting	Network residual capacity (%)	First arm reaching threshold
Left	Normal/unknown	0	Stream B-A

Traffic Demand

Demand Set Details

ID	Scenario name	Time Period name	Traffic profile type	Start time (HH:mm)	Finish time (HH:mm)	Time segment length (min)	Run automatically
D3	2028 Baseline	AM	ONE HOUR	07:45	09:15	15	✓

Vehicle mix varies over turn	Vehicle mix varies over entry	Vehicle mix source	PCU Factor for a HV (PCU)
✓	✓	HV Percentages	2.00

Demand overview (Traffic)

Arm	Linked arm	Profile type	Use O-D data	Average Demand (PCU/hr)	Scaling Factor (%)
A167 South		ONE HOUR	✓	669	100.000
Lamesley Lane		ONE HOUR	✓	339	100.000
A167 North		ONE HOUR	✓	491	100.000

Origin-Destination Data

Demand (PCU/hr)

		To		
		A167 South	Lamesley Lane	A167 North
From	A167 South	0	318	351
	Lamesley Lane	245	0	94
	A167 North	430	61	0

Vehicle Mix

Heavy Vehicle Percentages

		To		
		A167 South	Lamesley Lane	A167 North
From	A167 South	0	25	20
	Lamesley Lane	22	0	27
	A167 North	18	28	0

Results

Results Summary for whole modelled period

Stream	Max RFC	Max Delay (s)	Max Queue (PCU)	Max LOS	Average Demand (PCU/hr)	Total Junction Arrivals (PCU)
B-C	0.30	19.26	0.5	C	86	129
B-A	0.68	34.59	2.5	D	225	337
C-A					395	592
C-B	0.15	11.68	0.2	B	56	84
A-B					292	438
A-C					322	483

Main Results for each time segment

07:45 - 08:00

Stream	Total Demand (PCU/hr)	Junction Arrivals (PCU)	Capacity (PCU/hr)	RFC	Throughput (PCU/hr)	Start queue (PCU)	End queue (PCU)	Delay (s)	Unsignalised level of service
B-C	71	18	498	0.142	70	0.0	0.2	10.652	B
B-A	184	46	478	0.386	181	0.0	0.7	14.663	B
C-A	324	81			324				
C-B	46	11	516	0.089	45	0.0	0.1	9.780	A
A-B	239	60			239				
A-C	264	66			264				

08:00 - 08:15

Stream	Total Demand (PCU/hr)	Junction Arrivals (PCU)	Capacity (PCU/hr)	RFC	Throughput (PCU/hr)	Start queue (PCU)	End queue (PCU)	Delay (s)	Unsignalised level of service
B-C	85	21	449	0.188	84	0.2	0.3	12.528	B
B-A	220	55	444	0.496	219	0.7	1.2	19.334	C
C-A	387	97			387				
C-B	55	14	493	0.111	55	0.1	0.2	10.505	B
A-B	286	71			286				
A-C	316	79			316				

08:15 - 08:30

Stream	Total Demand (PCU/hr)	Junction Arrivals (PCU)	Capacity (PCU/hr)	RFC	Throughput (PCU/hr)	Start queue (PCU)	End queue (PCU)	Delay (s)	Unsignalised level of service
B-C	103	26	348	0.298	103	0.3	0.5	18.580	C
B-A	270	67	395	0.682	265	1.2	2.4	32.510	D
C-A	473	118			473				
C-B	67	17	461	0.146	67	0.2	0.2	11.670	B
A-B	350	88			350				
A-C	386	97			386				

08:30 - 08:45

Stream	Total Demand (PCU/hr)	Junction Arrivals (PCU)	Capacity (PCU/hr)	RFC	Throughput (PCU/hr)	Start queue (PCU)	End queue (PCU)	Delay (s)	Unsignalised level of service
B-C	103	26	341	0.304	103	0.5	0.5	19.262	C
B-A	270	67	395	0.683	269	2.4	2.5	34.586	D
C-A	473	118			473				
C-B	67	17	461	0.146	67	0.2	0.2	11.685	B
A-B	350	88			350				
A-C	386	97			386				

08:45 - 09:00

Stream	Total Demand (PCU/hr)	Junction Arrivals (PCU)	Capacity (PCU/hr)	RFC	Throughput (PCU/hr)	Start queue (PCU)	End queue (PCU)	Delay (s)	Unsignalised level of service
B-C	85	21	439	0.193	85	0.5	0.3	12.967	B
B-A	220	55	436	0.506	225	2.5	1.3	21.290	C
C-A	387	97			387				
C-B	55	14	493	0.111	55	0.2	0.2	10.522	B
A-B	286	71			286				
A-C	316	79			316				

09:00 - 09:15

Stream	Total Demand (PCU/hr)	Junction Arrivals (PCU)	Capacity (PCU/hr)	RFC	Throughput (PCU/hr)	Start queue (PCU)	End queue (PCU)	Delay (s)	Unsignalised level of service
B-C	71	18	495	0.143	71	0.3	0.2	10.790	B
B-A	184	46	478	0.386	187	1.3	0.8	15.166	C
C-A	324	81			324				
C-B	46	11	516	0.089	46	0.2	0.1	9.807	A
A-B	239	60			239				
A-C	264	66			264				

2028 Baseline, PM

Data Errors and Warnings

No errors or warnings

Junction Network

Junctions

Junction	Name	Junction type	Major road direction	Use circulating lanes	Junction Delay (s)	Junction LOS
1	untitled	T-Junction	Two-way		42.75	E

Junction Network Options

Driving side	Lighting	Network residual capacity (%)	First arm reaching threshold
Left	Normal/unknown	-19	Stream B-A

Traffic Demand

Demand Set Details

ID	Scenario name	Time Period name	Traffic profile type	Start time (HH:mm)	Finish time (HH:mm)	Time segment length (min)	Run automatically
D4	2028 Baseline	PM	ONE HOUR	16:45	18:15	15	✓

Vehicle mix varies over turn	Vehicle mix varies over entry	Vehicle mix source	PCU Factor for a HV (PCU)
✓	✓	HV Percentages	2.00

Demand overview (Traffic)

Arm	Linked arm	Profile type	Use O-D data	Average Demand (PCU/hr)	Scaling Factor (%)
A167 South		ONE HOUR	✓	603	100.000
Lamesley Lane		ONE HOUR	✓	393	100.000
A167 North		ONE HOUR	✓	689	100.000

Origin-Destination Data

Demand (PCU/hr)

		To		
		A167 South	Lamesley Lane	A167 North
From	A167 South	0	176	427
	Lamesley Lane	302	0	91
	A167 North	569	120	0

Vehicle Mix

Heavy Vehicle Percentages

		To		
		A167 South	Lamesley Lane	A167 North
From	A167 South	0	25	20
	Lamesley Lane	22	0	27
	A167 North	18	28	0

Results

Results Summary for whole modelled period

Stream	Max RFC	Max Delay (s)	Max Queue (PCU)	Max LOS	Average Demand (PCU/hr)	Total Junction Arrivals (PCU)
B-C	1.01	240.60	6.6	F	84	125
B-A	1.01	160.74	14.5	F	277	416
C-A					522	783
C-B	0.28	13.30	0.5	B	110	165
A-B					162	242
A-C					392	588

Main Results for each time segment

16:45 - 17:00

Stream	Total Demand (PCU/hr)	Junction Arrivals (PCU)	Capacity (PCU/hr)	RFC	Throughput (PCU/hr)	Start queue (PCU)	End queue (PCU)	Delay (s)	Unsignalised level of service
B-C	69	17	445	0.154	68	0.0	0.2	12.095	B
B-A	227	57	435	0.523	222	0.0	1.3	20.238	C
C-A	428	107			428				
C-B	90	23	528	0.171	89	0.0	0.3	10.493	B
A-B	133	33			133				
A-C	321	80			321				

17:00 - 17:15

Stream	Total Demand (PCU/hr)	Junction Arrivals (PCU)	Capacity (PCU/hr)	RFC	Throughput (PCU/hr)	Start queue (PCU)	End queue (PCU)	Delay (s)	Unsignalised level of service
B-C	82	20	344	0.238	81	0.2	0.4	17.364	C
B-A	271	68	393	0.692	267	1.3	2.5	33.654	D
C-A	512	128			512				
C-B	108	27	507	0.213	108	0.3	0.3	11.523	B
A-B	158	40			158				
A-C	384	96			384				

17:15 - 17:30

Stream	Total Demand (PCU/hr)	Junction Arrivals (PCU)	Capacity (PCU/hr)	RFC	Throughput (PCU/hr)	Start queue (PCU)	End queue (PCU)	Delay (s)	Unsignalised level of service
B-C	100	25	99	1.015	81	0.4	5.3	179.773	F
B-A	333	83	332	1.001	303	2.5	10.0	99.914	F
C-A	626	157			626				
C-B	132	33	479	0.276	132	0.3	0.5	13.260	B
A-B	194	48			194				
A-C	470	118			470				

17:30 - 17:45

Stream	Total Demand (PCU/hr)	Junction Arrivals (PCU)	Capacity (PCU/hr)	RFC	Throughput (PCU/hr)	Start queue (PCU)	End queue (PCU)	Delay (s)	Unsignalised level of service
B-C	100	25	107	0.934	95	5.3	6.6	240.600	F
B-A	333	83	329	1.010	314	10.0	14.5	160.737	F
C-A	626	157			626				
C-B	132	33	479	0.276	132	0.5	0.5	13.299	B
A-B	194	48			194				
A-C	470	118			470				

17:45 - 18:00

Stream	Total Demand (PCU/hr)	Junction Arrivals (PCU)	Capacity (PCU/hr)	RFC	Throughput (PCU/hr)	Start queue (PCU)	End queue (PCU)	Delay (s)	Unsignalised level of service
B-C	82	20	248	0.330	105	6.6	0.7	36.989	E
B-A	271	68	386	0.703	316	14.5	3.4	78.173	F
C-A	512	128			512				
C-B	108	27	507	0.213	108	0.5	0.4	11.572	B
A-B	158	40			158				
A-C	384	96			384				

18:00 - 18:15

Stream	Total Demand (PCU/hr)	Junction Arrivals (PCU)	Capacity (PCU/hr)	RFC	Throughput (PCU/hr)	Start queue (PCU)	End queue (PCU)	Delay (s)	Unsignalised level of service
B-C	69	17	431	0.159	70	0.7	0.2	12.710	B
B-A	227	57	434	0.524	235	3.4	1.4	22.879	C
C-A	428	107			428				
C-B	90	23	528	0.171	91	0.4	0.3	10.551	B
A-B	133	33			133				
A-C	321	80			321				

2028 Baseline + CD + Dev, AM

Data Errors and Warnings

No errors or warnings

Junction Network

Junctions

Junction	Name	Junction type	Major road direction	Use circulating lanes	Junction Delay (s)	Junction LOS
1	untitled	T-Junction	Two-way		14.73	B

Junction Network Options

Driving side	Lighting	Network residual capacity (%)	First arm reaching threshold
Left	Normal/unknown	-10	Stream B-A

Traffic Demand

Demand Set Details

ID	Scenario name	Time Period name	Traffic profile type	Start time (HH:mm)	Finish time (HH:mm)	Time segment length (min)	Run automatically
D5	2028 Baseline + CD + Dev	AM	ONE HOUR	07:45	09:15	15	✓

Vehicle mix varies over turn	Vehicle mix varies over entry	Vehicle mix source	PCU Factor for a HV (PCU)
✓	✓	HV Percentages	2.00

Demand overview (Traffic)

Arm	Linked arm	Profile type	Use O-D data	Average Demand (PCU/hr)	Scaling Factor (%)
A167 South		ONE HOUR	✓	747	100.000
Lamesley Lane		ONE HOUR	✓	387	100.000
A167 North		ONE HOUR	✓	520	100.000

Origin-Destination Data

Demand (PCU/hr)

		To		
		A167 South	Lamesley Lane	A167 North
From	A167 South	0	335	412
	Lamesley Lane	273	0	114
	A167 North	453	67	0

Vehicle Mix

Heavy Vehicle Percentages

		To		
		A167 South	Lamesley Lane	A167 North
From	A167 South	0	25	20
	Lamesley Lane	22	0	27
	A167 North	18	28	0

Results

Results Summary for whole modelled period

Stream	Max RFC	Max Delay (s)	Max Queue (PCU)	Max LOS	Average Demand (PCU/hr)	Total Junction Arrivals (PCU)
B-C	0.56	45.94	1.5	E	105	157
B-A	0.84	67.00	5.2	F	251	376
C-A					416	624
C-B	0.17	12.54	0.3	B	61	92
A-B					307	461
A-C					378	567

Main Results for each time segment

07:45 - 08:00

Stream	Total Demand (PCU/hr)	Junction Arrivals (PCU)	Capacity (PCU/hr)	RFC	Throughput (PCU/hr)	Start queue (PCU)	End queue (PCU)	Delay (s)	Unsignalised level of service
B-C	86	21	472	0.182	85	0.0	0.3	11.763	B
B-A	206	51	457	0.450	202	0.0	1.0	16.962	C
C-A	341	85			341				
C-B	50	13	502	0.100	50	0.0	0.1	10.172	B
A-B	252	63			252				
A-C	310	78			310				

08:00 - 08:15

Stream	Total Demand (PCU/hr)	Junction Arrivals (PCU)	Capacity (PCU/hr)	RFC	Throughput (PCU/hr)	Start queue (PCU)	End queue (PCU)	Delay (s)	Unsignalised level of service
B-C	102	26	404	0.254	102	0.3	0.4	15.110	C
B-A	245	61	418	0.587	243	1.0	1.6	24.647	C
C-A	407	102			407				
C-B	60	15	477	0.126	60	0.1	0.2	11.054	B
A-B	301	75			301				
A-C	370	93			370				

08:15 - 08:30

Stream	Total Demand (PCU/hr)	Junction Arrivals (PCU)	Capacity (PCU/hr)	RFC	Throughput (PCU/hr)	Start queue (PCU)	End queue (PCU)	Delay (s)	Unsignalised level of service
B-C	126	31	247	0.509	122	0.4	1.2	35.899	E
B-A	301	75	360	0.835	289	1.6	4.5	54.575	F
C-A	499	125			499				
C-B	74	18	441	0.167	73	0.2	0.3	12.527	B
A-B	369	92			369				
A-C	454	113			454				

08:30 - 08:45

Stream	Total Demand (PCU/hr)	Junction Arrivals (PCU)	Capacity (PCU/hr)	RFC	Throughput (PCU/hr)	Start queue (PCU)	End queue (PCU)	Delay (s)	Unsignalised level of service
B-C	126	31	222	0.565	124	1.2	1.5	45.944	E
B-A	301	75	359	0.838	298	4.5	5.2	67.005	F
C-A	499	125			499				
C-B	74	18	441	0.167	74	0.3	0.3	12.535	B
A-B	369	92			369				
A-C	454	113			454				

08:45 - 09:00

Stream	Total Demand (PCU/hr)	Junction Arrivals (PCU)	Capacity (PCU/hr)	RFC	Throughput (PCU/hr)	Start queue (PCU)	End queue (PCU)	Delay (s)	Unsignalised level of service
B-C	102	26	385	0.266	107	1.5	0.5	16.673	C
B-A	245	61	417	0.588	259	5.2	1.9	29.623	D
C-A	407	102			407				
C-B	60	15	477	0.126	61	0.3	0.2	11.077	B
A-B	301	75			301				
A-C	370	93			370				

09:00 - 09:15

Stream	Total Demand (PCU/hr)	Junction Arrivals (PCU)	Capacity (PCU/hr)	RFC	Throughput (PCU/hr)	Start queue (PCU)	End queue (PCU)	Delay (s)	Unsignalised level of service
B-C	86	21	467	0.184	87	0.5	0.3	12.042	B
B-A	206	51	457	0.450	209	1.9	1.0	17.935	C
C-A	341	85			341				
C-B	50	13	502	0.100	51	0.2	0.1	10.204	B
A-B	252	63			252				
A-C	310	78			310				

2028 Baseline + CD + Dev, PM

Data Errors and Warnings

No errors or warnings

Junction Network

Junctions

Junction	Name	Junction type	Major road direction	Use circulating lanes	Junction Delay (s)	Junction LOS
1	untitled	T-Junction	Two-way		79.96	F

Junction Network Options

Driving side	Lighting	Network residual capacity (%)	First arm reaching threshold
Left	Normal/unknown	-25	Stream B-A

Traffic Demand

Demand Set Details

ID	Scenario name	Time Period name	Traffic profile type	Start time (HH:mm)	Finish time (HH:mm)	Time segment length (min)	Run automatically
D6	2028 Baseline + CD + Dev	PM	ONE HOUR	16:45	18:15	15	✓

Vehicle mix varies over turn	Vehicle mix varies over entry	Vehicle mix source	PCU Factor for a HV (PCU)
✓	✓	HV Percentages	2.00

Demand overview (Traffic)

Arm	Linked arm	Profile type	Use O-D data	Average Demand (PCU/hr)	Scaling Factor (%)
A167 South		ONE HOUR	✓	656	100.000
Lamesley Lane		ONE HOUR	✓	419	100.000
A167 North		ONE HOUR	✓	761	100.000

Origin-Destination Data

Demand (PCU/hr)

		To		
		A167 South	Lamesley Lane	A167 North
From	A167 South	0	196	460
	Lamesley Lane	321	0	98
	A167 North	621	140	0

Vehicle Mix

Heavy Vehicle Percentages

		To		
		A167 South	Lamesley Lane	A167 North
From	A167 South	0	25	20
	Lamesley Lane	22	0	27
	A167 North	18	28	0

Results

Results Summary for whole modelled period

Stream	Max RFC	Max Delay (s)	Max Queue (PCU)	Max LOS	Average Demand (PCU/hr)	Total Junction Arrivals (PCU)
B-C	1.19	411.92	11.5	F	90	135
B-A	1.17	325.09	32.7	F	295	442
C-A					570	855
C-B	0.33	14.83	0.6	B	128	193
A-B					180	270
A-C					422	633

Main Results for each time segment

16:45 - 17:00

Stream	Total Demand (PCU/hr)	Junction Arrivals (PCU)	Capacity (PCU/hr)	RFC	Throughput (PCU/hr)	Start queue (PCU)	End queue (PCU)	Delay (s)	Unsignalised level of service
B-C	74	18	414	0.178	73	0.0	0.3	13.365	B
B-A	242	60	413	0.585	235	0.0	1.6	23.876	C
C-A	468	117			468				
C-B	105	26	518	0.203	104	0.0	0.3	11.088	B
A-B	148	37			148				
A-C	346	87			346				

17:00 - 17:15

Stream	Total Demand (PCU/hr)	Junction Arrivals (PCU)	Capacity (PCU/hr)	RFC	Throughput (PCU/hr)	Start queue (PCU)	End queue (PCU)	Delay (s)	Unsignalised level of service
B-C	88	22	272	0.323	87	0.3	0.6	24.469	C
B-A	289	72	367	0.787	280	1.6	3.7	46.939	E
C-A	558	140			558				
C-B	126	31	496	0.254	125	0.3	0.4	12.421	B
A-B	176	44			176				
A-C	414	103			414				

17:15 - 17:30

Stream	Total Demand (PCU/hr)	Junction Arrivals (PCU)	Capacity (PCU/hr)	RFC	Throughput (PCU/hr)	Start queue (PCU)	End queue (PCU)	Delay (s)	Unsignalised level of service
B-C	108	27	91	1.186	80	0.6	7.7	244.823	F
B-A	353	88	304	1.164	292	3.7	19.0	170.066	F
C-A	684	171			684				
C-B	154	39	465	0.332	153	0.4	0.6	14.758	B
A-B	216	54			216				
A-C	506	127			506				

17:30 - 17:45

Stream	Total Demand (PCU/hr)	Junction Arrivals (PCU)	Capacity (PCU/hr)	RFC	Throughput (PCU/hr)	Start queue (PCU)	End queue (PCU)	Delay (s)	Unsignalised level of service
B-C	108	27	97	1.108	93	7.7	11.5	411.920	F
B-A	353	88	302	1.172	299	19.0	32.7	325.093	F
C-A	684	171			684				
C-B	154	39	465	0.332	154	0.6	0.6	14.827	B
A-B	216	54			216				
A-C	506	127			506				

17:45 - 18:00

Stream	Total Demand (PCU/hr)	Junction Arrivals (PCU)	Capacity (PCU/hr)	RFC	Throughput (PCU/hr)	Start queue (PCU)	End queue (PCU)	Delay (s)	Unsignalised level of service
B-C	88	22	114	0.770	106	11.5	7.1	316.882	F
B-A	289	72	358	0.806	345	32.7	18.5	270.309	F
C-A	558	140			558				
C-B	126	31	496	0.254	127	0.6	0.4	12.503	B
A-B	176	44			176				
A-C	414	103			414				

18:00 - 18:15

Stream	Total Demand (PCU/hr)	Junction Arrivals (PCU)	Capacity (PCU/hr)	RFC	Throughput (PCU/hr)	Start queue (PCU)	End queue (PCU)	Delay (s)	Unsignalised level of service
B-C	74	18	310	0.238	100	7.1	0.4	24.542	C
B-A	242	60	408	0.592	308	18.5	2.0	65.099	F
C-A	468	117			468				
C-B	105	26	518	0.203	106	0.4	0.3	11.182	B
A-B	148	37			148				
A-C	346	87			346				

Junctions 9
PICADY 9 - Priority Intersection Module
Version: 9.5.1.7462 © Copyright TRL Limited, 2019
For sales and distribution information, program advice and maintenance, contact TRL: +44 (0)1344 379777 software@trl.co.uk www.trlsoftware.co.uk
The users of this computer program for the solution of an engineering problem are in no way relieved of their responsibility for the correctness of the solution

Filename: Import of A167-Edward Road.j9
Path: P:\22 Jobs\024-N Former BAE site, Birtley, Gateshead\Technical Assessments\Junctions9
Report generation date: 17/06/2022 16:08:45

- »2022 Baseline, AM
- »2022 Baseline, PM
- »2028 Baseline, AM
- »2028 Baseline, PM
- »2028 Baseline + CD + Dev, AM
- »2028 Baseline + CD + Dev, PM

Summary of junction performance

	AM						PM					
	Set ID	Queue (PCU)	Delay (s)	RFC	LOS	Network Residual Capacity	Set ID	Queue (PCU)	Delay (s)	RFC	LOS	Network Residual Capacity
2022 Baseline												
Stream B-AC	D1	0.2	10.63	0.17	B	83 %	D2	0.3	10.39	0.18	B	78 %
Stream C-AB		0.7	5.68	0.22	A	[Stream C-AB]		0.8	5.66	0.22	A	[Stream C-AB]
2028 Baseline												
Stream B-AC	D3	0.3	11.05	0.18	B	74 %	D4	0.3	10.79	0.19	B	68 %
Stream C-AB		0.8	5.69	0.25	A	[Stream C-AB]		0.9	5.67	0.24	A	[Stream C-AB]
2028 Baseline + CD + Dev												
Stream B-AC	D5	0.7	13.79	0.37	B	45 %	D6	0.5	13.13	0.30	B	33 %
Stream C-AB		1.1	6.12	0.31	A	[Stream B-AC]		2.1	8.00	0.46	A	[Stream C-AB]

Values shown are the highest values encountered over all time segments. Delay is the maximum value of average delay per arriving vehicle. Network Residual Capacity indicates the amount by which network flow could be increased before a user-definable threshold (see Analysis Options) is met.

File summary

File Description

Title	
Location	
Site number	
Date	27/04/2022
Version	
Status	(new file)
Identifier	
Client	
Jobnumber	
Enumerator	mtp\awreford
Description	

Units

Distance units	Speed units	Traffic units input	Traffic units results	Flow units	Average delay units	Total delay units	Rate of delay units
m	kph	PCU	PCU	perHour	s	-Min	perMin

Analysis Options

Vehicle length (m)	Calculate Queue Percentiles	Calculate detailed queueing delay	Calculate residual capacity	Residual capacity criteria type	RFC Threshold	Average Delay threshold (s)	Queue threshold (PCU)
5.75			✓	Delay	0.85	36.00	20.00

Demand Set Summary

ID	Scenario name	Time Period name	Traffic profile type	Start time (HH:mm)	Finish time (HH:mm)	Time segment length (min)	Run automatically
D1	2022 Baseline	AM	ONE HOUR	07:45	09:15	15	✓
D2	2022 Baseline	PM	ONE HOUR	16:45	18:15	15	✓
D3	2028 Baseline	AM	ONE HOUR	07:45	09:15	15	✓
D4	2028 Baseline	PM	ONE HOUR	16:45	18:15	15	✓
D5	2028 Baseline + CD + Dev	AM	ONE HOUR	07:45	09:15	15	✓
D6	2028 Baseline + CD + Dev	PM	ONE HOUR	16:45	18:15	15	✓

Analysis Set Details

ID	Include in report	Network flow scaling factor (%)	Network capacity scaling factor (%)
A1	✓	100.000	100.000

2022 Baseline, AM

Data Errors and Warnings

No errors or warnings

Junction Network

Junctions

Junction	Name	Junction type	Major road direction	Use circulating lanes	Junction Delay (s)	Junction LOS
1	untitled	T-Junction	Two-way		1.67	A

Junction Network Options

Driving side	Lighting	Network residual capacity (%)	First arm reaching threshold
Left	Normal/unknown	83	Stream C-AB

Arms

Arms

Arm	Name	Description	Arm type
A	A167 South		Major
B	Edward Road		Minor
C	A167 North		Major

Major Arm Geometry

Arm	Width of carriageway (m)	Has kerbed central reserve	Has right turn bay	Visibility for right turn (m)	Blocks?	Blocking queue (PCU)
A167 North	7.85			69.4	✓	0.00

Geometries for Arm C are measured opposite Arm B. Geometries for Arm A (if relevant) are measured opposite Arm D.

Minor Arm Geometry

Arm	Minor arm type	Lane width (m)	Visibility to left (m)	Visibility to right (m)
Edward Road	One lane	4.39	60	34

Slope / Intercept / Capacity

Priority Intersection Slopes and Intercepts

Stream	Intercept (PCU/hr)	Slope for A-B	Slope for A-C	Slope for C-A	Slope for C-B
B-A	585	0.098	0.248	0.156	0.354
B-C	735	0.104	0.262	-	-
C-B	614	0.219	0.219	-	-

The slopes and intercepts shown above do NOT include any corrections or adjustments.

Streams may be combined, in which case capacity will be adjusted.

Values are shown for the first time segment only; they may differ for subsequent time segments.

Traffic Demand

Demand Set Details

ID	Scenario name	Time Period name	Traffic profile type	Start time (HH:mm)	Finish time (HH:mm)	Time segment length (min)	Run automatically
D1	2022 Baseline	AM	ONE HOUR	07:45	09:15	15	✓

Vehicle mix varies over turn	Vehicle mix varies over entry	Vehicle mix source	PCU Factor for a HV (PCU)
✓	✓	HV Percentages	2.00

Demand overview (Traffic)

Arm	Linked arm	Profile type	Use O-D data	Average Demand (PCU/hr)	Scaling Factor (%)
A167 South		ONE HOUR	✓	334	100.000
Edward Road		ONE HOUR	✓	73	100.000
A167 North		ONE HOUR	✓	639	100.000

Origin-Destination Data

Demand (PCU/hr)

		To		
		A167 South	Edward Road	A167 North
From	A167 South	0	41	293
	Edward Road	35	0	38
	A167 North	569	70	0

Vehicle Mix

Heavy Vehicle Percentages

		To		
		A167 South	Edward Road	A167 North
From	A167 South	0	18	23
	Edward Road	24	0	13
	A167 North	20	15	0

Results

Results Summary for whole modelled period

Stream	Max RFC	Max Delay (s)	Max Queue (PCU)	Max LOS	Average Demand (PCU/hr)	Total Junction Arrivals (PCU)
B-AC	0.17	10.63	0.2	B	67	100
C-AB	0.22	5.68	0.7	A	157	235
C-A					430	645
A-B					38	56
A-C					269	403

Main Results for each time segment

07:45 - 08:00

Stream	Total Demand (PCU/hr)	Junction Arrivals (PCU)	Capacity (PCU/hr)	RFC	Throughput (PCU/hr)	Start queue (PCU)	End queue (PCU)	Delay (s)	Unsignalised level of service
B-AC	55	14	539	0.102	54	0.0	0.1	8.765	A
C-AB	106	26	854	0.124	104	0.0	0.3	5.637	A
C-A	375	94			375				
A-B	31	8			31				
A-C	221	55			221				

08:00 - 08:15

Stream	Total Demand (PCU/hr)	Junction Arrivals (PCU)	Capacity (PCU/hr)	RFC	Throughput (PCU/hr)	Start queue (PCU)	End queue (PCU)	Delay (s)	Unsignalised level of service
B-AC	66	16	514	0.128	65	0.1	0.2	9.461	A
C-AB	146	36	905	0.161	145	0.3	0.5	5.587	A
C-A	429	107			429				
A-B	37	9			37				
A-C	263	66			263				

08:15 - 08:30

Stream	Total Demand (PCU/hr)	Junction Arrivals (PCU)	Capacity (PCU/hr)	RFC	Throughput (PCU/hr)	Start queue (PCU)	End queue (PCU)	Delay (s)	Unsignalised level of service
B-AC	80	20	480	0.167	80	0.2	0.2	10.615	B
C-AB	217	54	975	0.223	216	0.5	0.7	5.610	A
C-A	486	122			486				
A-B	45	11			45				
A-C	323	81			323				

08:30 - 08:45

Stream	Total Demand (PCU/hr)	Junction Arrivals (PCU)	Capacity (PCU/hr)	RFC	Throughput (PCU/hr)	Start queue (PCU)	End queue (PCU)	Delay (s)	Unsignalised level of service
B-AC	80	20	480	0.167	80	0.2	0.2	10.632	B
C-AB	218	54	976	0.223	218	0.7	0.7	5.635	A
C-A	486	121			486				
A-B	45	11			45				
A-C	323	81			323				

08:45 - 09:00

Stream	Total Demand (PCU/hr)	Junction Arrivals (PCU)	Capacity (PCU/hr)	RFC	Throughput (PCU/hr)	Start queue (PCU)	End queue (PCU)	Delay (s)	Unsignalised level of service
B-AC	66	16	514	0.128	66	0.2	0.2	9.484	A
C-AB	146	37	905	0.162	147	0.7	0.5	5.628	A
C-A	428	107			428				
A-B	37	9			37				
A-C	263	66			263				

09:00 - 09:15

Stream	Total Demand (PCU/hr)	Junction Arrivals (PCU)	Capacity (PCU/hr)	RFC	Throughput (PCU/hr)	Start queue (PCU)	End queue (PCU)	Delay (s)	Unsignalised level of service
B-AC	55	14	538	0.102	55	0.2	0.1	8.797	A
C-AB	107	27	855	0.125	107	0.5	0.3	5.677	A
C-A	375	94			375				
A-B	31	8			31				
A-C	221	55			221				

2022 Baseline, PM

Data Errors and Warnings

No errors or warnings

Junction Network

Junctions

Junction	Name	Junction type	Major road direction	Use circulating lanes	Junction Delay (s)	Junction LOS
1	untitled	T-Junction	Two-way		1.48	A

Junction Network Options

Driving side	Lighting	Network residual capacity (%)	First arm reaching threshold
Left	Normal/unknown	78	Stream C-AB

Traffic Demand

Demand Set Details

ID	Scenario name	Time Period name	Traffic profile type	Start time (HH:mm)	Finish time (HH:mm)	Time segment length (min)	Run automatically
D2	2022 Baseline	PM	ONE HOUR	16:45	18:15	15	✓

Vehicle mix varies over turn	Vehicle mix varies over entry	Vehicle mix source	PCU Factor for a HV (PCU)
✓	✓	HV Percentages	2.00

Demand overview (Traffic)

Arm	Linked arm	Profile type	Use O-D data	Average Demand (PCU/hr)	Scaling Factor (%)
A167 South		ONE HOUR	✓	456	100.000
Edward Road		ONE HOUR	✓	81	100.000
A167 North		ONE HOUR	✓	656	100.000

Origin-Destination Data

Demand (PCU/hr)

		To		
		A167 South	Edward Road	A167 North
From	A167 South	0	22	434
	Edward Road	24	0	57
	A167 North	593	63	0

Vehicle Mix

Heavy Vehicle Percentages

		To		
		A167 South	Edward Road	A167 North
From	A167 South	0	18	23
	Edward Road	24	0	13
	A167 North	20	15	0

Results

Results Summary for whole modelled period

Stream	Max RFC	Max Delay (s)	Max Queue (PCU)	Max LOS	Average Demand (PCU/hr)	Total Junction Arrivals (PCU)
B-AC	0.18	10.39	0.3	B	74	111
C-AB	0.22	5.66	0.8	A	151	226
C-A					451	677
A-B					20	30
A-C					398	597

Main Results for each time segment

16:45 - 17:00

Stream	Total Demand (PCU/hr)	Junction Arrivals (PCU)	Capacity (PCU/hr)	RFC	Throughput (PCU/hr)	Start queue (PCU)	End queue (PCU)	Delay (s)	Unsignalised level of service
B-AC	61	15	556	0.110	60	0.0	0.1	8.418	A
C-AB	100	25	852	0.117	98	0.0	0.3	5.618	A
C-A	394	99			394				
A-B	17	4			17				
A-C	327	82			327				

17:00 - 17:15

Stream	Total Demand (PCU/hr)	Junction Arrivals (PCU)	Capacity (PCU/hr)	RFC	Throughput (PCU/hr)	Start queue (PCU)	End queue (PCU)	Delay (s)	Unsignalised level of service
B-AC	73	18	529	0.138	73	0.1	0.2	9.143	A
C-AB	139	35	903	0.154	139	0.3	0.5	5.560	A
C-A	450	113			450				
A-B	20	5			20				
A-C	390	98			390				

17:15 - 17:30

Stream	Total Demand (PCU/hr)	Junction Arrivals (PCU)	Capacity (PCU/hr)	RFC	Throughput (PCU/hr)	Start queue (PCU)	End queue (PCU)	Delay (s)	Unsignalised level of service
B-AC	89	22	491	0.182	89	0.2	0.3	10.377	B
C-AB	212	53	975	0.217	211	0.5	0.7	5.578	A
C-A	510	128			510				
A-B	24	6			24				
A-C	478	119			478				

17:30 - 17:45

Stream	Total Demand (PCU/hr)	Junction Arrivals (PCU)	Capacity (PCU/hr)	RFC	Throughput (PCU/hr)	Start queue (PCU)	End queue (PCU)	Delay (s)	Unsignalised level of service
B-AC	89	22	491	0.182	89	0.3	0.3	10.395	B
C-AB	213	53	976	0.218	212	0.7	0.8	5.604	A
C-A	510	127			510				
A-B	24	6			24				
A-C	478	119			478				

17:45 - 18:00

Stream	Total Demand (PCU/hr)	Junction Arrivals (PCU)	Capacity (PCU/hr)	RFC	Throughput (PCU/hr)	Start queue (PCU)	End queue (PCU)	Delay (s)	Unsignalised level of service
B-AC	73	18	529	0.138	73	0.3	0.2	9.165	A
C-AB	140	35	904	0.155	141	0.8	0.5	5.604	A
C-A	450	112			450				
A-B	20	5			20				
A-C	390	98			390				

18:00 - 18:15

Stream	Total Demand (PCU/hr)	Junction Arrivals (PCU)	Capacity (PCU/hr)	RFC	Throughput (PCU/hr)	Start queue (PCU)	End queue (PCU)	Delay (s)	Unsignalised level of service
B-AC	61	15	556	0.110	61	0.2	0.1	8.448	A
C-AB	101	25	853	0.118	101	0.5	0.3	5.660	A
C-A	393	98			393				
A-B	17	4			17				
A-C	327	82			327				

2028 Baseline, AM

Data Errors and Warnings

No errors or warnings

Junction Network

Junctions

Junction	Name	Junction type	Major road direction	Use circulating lanes	Junction Delay (s)	Junction LOS
1	untitled	T-Junction	Two-way		1.75	A

Junction Network Options

Driving side	Lighting	Network residual capacity (%)	First arm reaching threshold
Left	Normal/unknown	74	Stream C-AB

Traffic Demand

Demand Set Details

ID	Scenario name	Time Period name	Traffic profile type	Start time (HH:mm)	Finish time (HH:mm)	Time segment length (min)	Run automatically
D3	2028 Baseline	AM	ONE HOUR	07:45	09:15	15	✓

Vehicle mix varies over turn	Vehicle mix varies over entry	Vehicle mix source	PCU Factor for a HV (PCU)
✓	✓	HV Percentages	2.00

Demand overview (Traffic)

Arm	Linked arm	Profile type	Use O-D data	Average Demand (PCU/hr)	Scaling Factor (%)
A167 South		ONE HOUR	✓	353	100.000
Edward Road		ONE HOUR	✓	77	100.000
A167 North		ONE HOUR	✓	673	100.000

Origin-Destination Data

Demand (PCU/hr)

		To		
		A167 South	Edward Road	A167 North
From	A167 South	0	44	309
	Edward Road	37	0	40
	A167 North	599	74	0

Vehicle Mix

Heavy Vehicle Percentages

		To		
		A167 South	Edward Road	A167 North
From	A167 South	0	18	23
	Edward Road	24	0	13
	A167 North	20	15	0

Results

Results Summary for whole modelled period

Stream	Max RFC	Max Delay (s)	Max Queue (PCU)	Max LOS	Average Demand (PCU/hr)	Total Junction Arrivals (PCU)
B-AC	0.18	11.05	0.3	B	71	106
C-AB	0.25	5.69	0.8	A	174	261
C-A					444	665
A-B					40	61
A-C					284	425

Main Results for each time segment

07:45 - 08:00

Stream	Total Demand (PCU/hr)	Junction Arrivals (PCU)	Capacity (PCU/hr)	RFC	Throughput (PCU/hr)	Start queue (PCU)	End queue (PCU)	Delay (s)	Unsignalised level of service
B-AC	58	14	532	0.109	57	0.0	0.1	8.948	A
C-AB	116	29	868	0.134	115	0.0	0.4	5.620	A
C-A	391	98			391				
A-B	33	8			33				
A-C	233	58			233				

08:00 - 08:15

Stream	Total Demand (PCU/hr)	Junction Arrivals (PCU)	Capacity (PCU/hr)	RFC	Throughput (PCU/hr)	Start queue (PCU)	End queue (PCU)	Delay (s)	Unsignalised level of service
B-AC	69	17	506	0.137	69	0.1	0.2	9.719	A
C-AB	161	40	921	0.175	161	0.4	0.5	5.585	A
C-A	444	111			444				
A-B	40	10			40				
A-C	278	69			278				

08:15 - 08:30

Stream	Total Demand (PCU/hr)	Junction Arrivals (PCU)	Capacity (PCU/hr)	RFC	Throughput (PCU/hr)	Start queue (PCU)	End queue (PCU)	Delay (s)	Unsignalised level of service
B-AC	85	21	469	0.181	84	0.2	0.3	11.031	B
C-AB	244	61	996	0.245	242	0.5	0.8	5.661	A
C-A	497	124			497				
A-B	48	12			48				
A-C	340	85			340				

08:30 - 08:45

Stream	Total Demand (PCU/hr)	Junction Arrivals (PCU)	Capacity (PCU/hr)	RFC	Throughput (PCU/hr)	Start queue (PCU)	End queue (PCU)	Delay (s)	Unsignalised level of service
B-AC	85	21	469	0.181	85	0.3	0.3	11.052	B
C-AB	244	61	996	0.245	244	0.8	0.8	5.689	A
C-A	497	124			497				
A-B	48	12			48				
A-C	340	85			340				

08:45 - 09:00

Stream	Total Demand (PCU/hr)	Junction Arrivals (PCU)	Capacity (PCU/hr)	RFC	Throughput (PCU/hr)	Start queue (PCU)	End queue (PCU)	Delay (s)	Unsignalised level of service
B-AC	69	17	506	0.137	69	0.3	0.2	9.750	A
C-AB	162	41	922	0.176	163	0.8	0.5	5.635	A
C-A	443	111			443				
A-B	40	10			40				
A-C	278	69			278				

09:00 - 09:15

Stream	Total Demand (PCU/hr)	Junction Arrivals (PCU)	Capacity (PCU/hr)	RFC	Throughput (PCU/hr)	Start queue (PCU)	End queue (PCU)	Delay (s)	Unsignalised level of service
B-AC	58	14	531	0.109	58	0.2	0.1	8.983	A
C-AB	117	29	869	0.135	118	0.5	0.4	5.664	A
C-A	390	97			390				
A-B	33	8			33				
A-C	233	58			233				

2028 Baseline, PM

Data Errors and Warnings

No errors or warnings

Junction Network

Junctions

Junction	Name	Junction type	Major road direction	Use circulating lanes	Junction Delay (s)	Junction LOS
1	untitled	T-Junction	Two-way		1.56	A

Junction Network Options

Driving side	Lighting	Network residual capacity (%)	First arm reaching threshold
Left	Normal/unknown	68	Stream C-AB

Traffic Demand

Demand Set Details

ID	Scenario name	Time Period name	Traffic profile type	Start time (HH:mm)	Finish time (HH:mm)	Time segment length (min)	Run automatically
D4	2028 Baseline	PM	ONE HOUR	16:45	18:15	15	✓

Vehicle mix varies over turn	Vehicle mix varies over entry	Vehicle mix source	PCU Factor for a HV (PCU)
✓	✓	HV Percentages	2.00

Demand overview (Traffic)

Arm	Linked arm	Profile type	Use O-D data	Average Demand (PCU/hr)	Scaling Factor (%)
A167 South		ONE HOUR	✓	479	100.000
Edward Road		ONE HOUR	✓	85	100.000
A167 North		ONE HOUR	✓	690	100.000

Origin-Destination Data

Demand (PCU/hr)

		To		
		A167 South	Edward Road	A167 North
From	A167 South	0	23	456
	Edward Road	25	0	60
	A167 North	623	67	0

Vehicle Mix

Heavy Vehicle Percentages

		To		
		A167 South	Edward Road	A167 North
From	A167 South	0	18	23
	Edward Road	24	0	13
	A167 North	20	15	0

Results

Results Summary for whole modelled period

Stream	Max RFC	Max Delay (s)	Max Queue (PCU)	Max LOS	Average Demand (PCU/hr)	Total Junction Arrivals (PCU)
B-AC	0.19	10.79	0.3	B	78	117
C-AB	0.24	5.67	0.9	A	169	253
C-A					464	696
A-B					21	32
A-C					418	628

Main Results for each time segment

16:45 - 17:00

Stream	Total Demand (PCU/hr)	Junction Arrivals (PCU)	Capacity (PCU/hr)	RFC	Throughput (PCU/hr)	Start queue (PCU)	End queue (PCU)	Delay (s)	Unsignalised level of service
B-AC	64	16	550	0.116	63	0.0	0.2	8.577	A
C-AB	110	28	865	0.127	109	0.0	0.3	5.604	A
C-A	409	102			409				
A-B	17	4			17				
A-C	343	86			343				

17:00 - 17:15

Stream	Total Demand (PCU/hr)	Junction Arrivals (PCU)	Capacity (PCU/hr)	RFC	Throughput (PCU/hr)	Start queue (PCU)	End queue (PCU)	Delay (s)	Unsignalised level of service
B-AC	76	19	521	0.147	76	0.2	0.2	9.377	A
C-AB	155	39	919	0.169	155	0.3	0.5	5.565	A
C-A	465	116			465				
A-B	21	5			21				
A-C	410	102			410				

17:15 - 17:30

Stream	Total Demand (PCU/hr)	Junction Arrivals (PCU)	Capacity (PCU/hr)	RFC	Throughput (PCU/hr)	Start queue (PCU)	End queue (PCU)	Delay (s)	Unsignalised level of service
B-AC	94	23	481	0.195	93	0.2	0.3	10.770	B
C-AB	240	60	996	0.241	238	0.5	0.9	5.639	A
C-A	520	130			520				
A-B	25	6			25				
A-C	502	126			502				

17:30 - 17:45

Stream	Total Demand (PCU/hr)	Junction Arrivals (PCU)	Capacity (PCU/hr)	RFC	Throughput (PCU/hr)	Start queue (PCU)	End queue (PCU)	Delay (s)	Unsignalised level of service
B-AC	94	23	481	0.195	94	0.3	0.3	10.792	B
C-AB	240	60	996	0.241	240	0.9	0.9	5.669	A
C-A	519	130			519				
A-B	25	6			25				
A-C	502	126			502				

17:45 - 18:00

Stream	Total Demand (PCU/hr)	Junction Arrivals (PCU)	Capacity (PCU/hr)	RFC	Throughput (PCU/hr)	Start queue (PCU)	End queue (PCU)	Delay (s)	Unsignalised level of service
B-AC	76	19	521	0.147	77	0.3	0.2	9.402	A
C-AB	156	39	920	0.170	158	0.9	0.5	5.613	A
C-A	464	116			464				
A-B	21	5			21				
A-C	410	102			410				

18:00 - 18:15

Stream	Total Demand (PCU/hr)	Junction Arrivals (PCU)	Capacity (PCU/hr)	RFC	Throughput (PCU/hr)	Start queue (PCU)	End queue (PCU)	Delay (s)	Unsignalised level of service
B-AC	64	16	550	0.116	64	0.2	0.2	8.611	A
C-AB	111	28	866	0.129	112	0.5	0.4	5.649	A
C-A	408	102			408				
A-B	17	4			17				
A-C	343	86			343				

2028 Baseline + CD + Dev, AM

Data Errors and Warnings

No errors or warnings

Junction Network

Junctions

Junction	Name	Junction type	Major road direction	Use circulating lanes	Junction Delay (s)	Junction LOS
1	untitled	T-Junction	Two-way		2.94	A

Junction Network Options

Driving side	Lighting	Network residual capacity (%)	First arm reaching threshold
Left	Normal/unknown	45	Stream B-AC

Traffic Demand

Demand Set Details

ID	Scenario name	Time Period name	Traffic profile type	Start time (HH:mm)	Finish time (HH:mm)	Time segment length (min)	Run automatically
D5	2028 Baseline + CD + Dev	AM	ONE HOUR	07:45	09:15	15	✓

Vehicle mix varies over turn	Vehicle mix varies over entry	Vehicle mix source	PCU Factor for a HV (PCU)
✓	✓	HV Percentages	2.00

Demand overview (Traffic)

Arm	Linked arm	Profile type	Use O-D data	Average Demand (PCU/hr)	Scaling Factor (%)
A167 South		ONE HOUR	✓	378	100.000
Edward Road		ONE HOUR	✓	160	100.000
A167 North		ONE HOUR	✓	723	100.000

Origin-Destination Data

Demand (PCU/hr)

		To		
		A167 South	Edward Road	A167 North
From	A167 South	0	50	328
	Edward Road	61	0	99
	A167 North	633	90	0

Vehicle Mix

Heavy Vehicle Percentages

		To		
		A167 South	Edward Road	A167 North
From	A167 South	0	18	23
	Edward Road	24	0	13
	A167 North	20	15	0

Results

Results Summary for whole modelled period

Stream	Max RFC	Max Delay (s)	Max Queue (PCU)	Max LOS	Average Demand (PCU/hr)	Total Junction Arrivals (PCU)
B-AC	0.37	13.79	0.7	B	147	220
C-AB	0.31	6.12	1.1	A	224	337
C-A					439	659
A-B					46	69
A-C					301	451

Main Results for each time segment

07:45 - 08:00

Stream	Total Demand (PCU/hr)	Junction Arrivals (PCU)	Capacity (PCU/hr)	RFC	Throughput (PCU/hr)	Start queue (PCU)	End queue (PCU)	Delay (s)	Unsignalised level of service
B-AC	120	30	546	0.221	119	0.0	0.3	9.836	A
C-AB	147	37	882	0.167	146	0.0	0.5	5.748	A
C-A	397	99			397				
A-B	38	9			38				
A-C	247	62			247				

08:00 - 08:15

Stream	Total Demand (PCU/hr)	Junction Arrivals (PCU)	Capacity (PCU/hr)	RFC	Throughput (PCU/hr)	Start queue (PCU)	End queue (PCU)	Delay (s)	Unsignalised level of service
B-AC	144	36	520	0.277	143	0.3	0.4	11.180	B
C-AB	207	52	939	0.220	206	0.4	0.7	5.801	A
C-A	443	111			443				
A-B	45	11			45				
A-C	295	74			295				

08:15 - 08:30

Stream	Total Demand (PCU/hr)	Junction Arrivals (PCU)	Capacity (PCU/hr)	RFC	Throughput (PCU/hr)	Start queue (PCU)	End queue (PCU)	Delay (s)	Unsignalised level of service
B-AC	176	44	482	0.366	175	0.4	0.7	13.707	B
C-AB	317	79	1019	0.311	315	0.7	1.1	6.074	A
C-A	479	120			479				
A-B	55	14			55				
A-C	361	90			361				

08:30 - 08:45

Stream	Total Demand (PCU/hr)	Junction Arrivals (PCU)	Capacity (PCU/hr)	RFC	Throughput (PCU/hr)	Start queue (PCU)	End queue (PCU)	Delay (s)	Unsignalised level of service
B-AC	176	44	481	0.366	176	0.7	0.7	13.790	B
C-AB	318	80	1020	0.312	318	1.1	1.1	6.117	A
C-A	478	119			478				
A-B	55	14			55				
A-C	361	90			361				

08:45 - 09:00

Stream	Total Demand (PCU/hr)	Junction Arrivals (PCU)	Capacity (PCU/hr)	RFC	Throughput (PCU/hr)	Start queue (PCU)	End queue (PCU)	Delay (s)	Unsignalised level of service
B-AC	144	36	519	0.277	145	0.7	0.5	11.271	B
C-AB	208	52	940	0.221	210	1.1	0.7	5.869	A
C-A	442	110			442				
A-B	45	11			45				
A-C	295	74			295				

09:00 - 09:15

Stream	Total Demand (PCU/hr)	Junction Arrivals (PCU)	Capacity (PCU/hr)	RFC	Throughput (PCU/hr)	Start queue (PCU)	End queue (PCU)	Delay (s)	Unsignalised level of service
B-AC	120	30	546	0.221	121	0.5	0.3	9.928	A
C-AB	149	37	884	0.168	150	0.7	0.5	5.804	A
C-A	396	99			396				
A-B	38	9			38				
A-C	247	62			247				

2028 Baseline + CD + Dev, PM

Data Errors and Warnings

No errors or warnings

Junction Network

Junctions

Junction	Name	Junction type	Major road direction	Use circulating lanes	Junction Delay (s)	Junction LOS
1	untitled	T-Junction	Two-way		3.14	A

Junction Network Options

Driving side	Lighting	Network residual capacity (%)	First arm reaching threshold
Left	Normal/unknown	33	Stream C-AB

Traffic Demand

Demand Set Details

ID	Scenario name	Time Period name	Traffic profile type	Start time (HH:mm)	Finish time (HH:mm)	Time segment length (min)	Run automatically
D6	2028 Baseline + CD + Dev	PM	ONE HOUR	16:45	18:15	15	✓

Vehicle mix varies over turn	Vehicle mix varies over entry	Vehicle mix source	PCU Factor for a HV (PCU)
✓	✓	HV Percentages	2.00

Demand overview (Traffic)

Arm	Linked arm	Profile type	Use O-D data	Average Demand (PCU/hr)	Scaling Factor (%)
A167 South		ONE HOUR	✓	526	100.000
Edward Road		ONE HOUR	✓	124	100.000
A167 North		ONE HOUR	✓	761	100.000

Origin-Destination Data

Demand (PCU/hr)

		To		
		A167 South	Edward Road	A167 North
From	A167 South	0	46	480
	Edward Road	36	0	88
	A167 North	638	123	0

Vehicle Mix

Heavy Vehicle Percentages

		To		
		A167 South	Edward Road	A167 North
From	A167 South	0	18	23
	Edward Road	24	0	13
	A167 North	20	15	0

Results

Results Summary for whole modelled period

Stream	Max RFC	Max Delay (s)	Max Queue (PCU)	Max LOS	Average Demand (PCU/hr)	Total Junction Arrivals (PCU)
B-AC	0.30	13.13	0.5	B	114	171
C-AB	0.46	8.00	2.1	A	322	483
C-A					376	564
A-B					42	63
A-C					440	661

Main Results for each time segment

16:45 - 17:00

Stream	Total Demand (PCU/hr)	Junction Arrivals (PCU)	Capacity (PCU/hr)	RFC	Throughput (PCU/hr)	Start queue (PCU)	End queue (PCU)	Delay (s)	Unsignalised level of service
B-AC	93	23	535	0.174	92	0.0	0.2	9.412	A
C-AB	208	52	867	0.239	205	0.0	0.7	6.398	A
C-A	365	91			365				
A-B	35	9			35				
A-C	361	90			361				

17:00 - 17:15

Stream	Total Demand (PCU/hr)	Junction Arrivals (PCU)	Capacity (PCU/hr)	RFC	Throughput (PCU/hr)	Start queue (PCU)	End queue (PCU)	Delay (s)	Unsignalised level of service
B-AC	111	28	502	0.222	111	0.2	0.3	10.661	B
C-AB	295	74	923	0.320	294	0.7	1.1	6.773	A
C-A	389	97			389				
A-B	41	10			41				
A-C	432	108			432				

17:15 - 17:30

Stream	Total Demand (PCU/hr)	Junction Arrivals (PCU)	Capacity (PCU/hr)	RFC	Throughput (PCU/hr)	Start queue (PCU)	End queue (PCU)	Delay (s)	Unsignalised level of service
B-AC	137	34	455	0.300	136	0.3	0.5	13.057	B
C-AB	460	115	1002	0.459	456	1.1	2.0	7.862	A
C-A	378	94			378				
A-B	51	13			51				
A-C	528	132			528				

17:30 - 17:45

Stream	Total Demand (PCU/hr)	Junction Arrivals (PCU)	Capacity (PCU/hr)	RFC	Throughput (PCU/hr)	Start queue (PCU)	End queue (PCU)	Delay (s)	Unsignalised level of service
B-AC	137	34	454	0.300	137	0.5	0.5	13.130	B
C-AB	463	116	1004	0.461	463	2.0	2.1	7.998	A
C-A	375	94			375				
A-B	51	13			51				
A-C	528	132			528				

17:45 - 18:00

Stream	Total Demand (PCU/hr)	Junction Arrivals (PCU)	Capacity (PCU/hr)	RFC	Throughput (PCU/hr)	Start queue (PCU)	End queue (PCU)	Delay (s)	Unsignalised level of service
B-AC	111	28	502	0.222	112	0.5	0.3	10.733	B
C-AB	298	74	926	0.322	301	2.1	1.1	6.918	A
C-A	386	97			386				
A-B	41	10			41				
A-C	432	108			432				

18:00 - 18:15

Stream	Total Demand (PCU/hr)	Junction Arrivals (PCU)	Capacity (PCU/hr)	RFC	Throughput (PCU/hr)	Start queue (PCU)	End queue (PCU)	Delay (s)	Unsignalised level of service
B-AC	93	23	534	0.175	94	0.3	0.2	9.481	A
C-AB	210	52	869	0.242	212	1.1	0.7	6.505	A
C-A	363	91			363				
A-B	35	9			35				
A-C	361	90			361				

Junctions 9
PICADY 9 - Priority Intersection Module
Version: 9.5.1.7462 © Copyright TRL Limited, 2019
For sales and distribution information, program advice and maintenance, contact TRL: +44 (0)1344 379777 software@trl.co.uk www.trlsoftware.co.uk
The users of this computer program for the solution of an engineering problem are in no way relieved of their responsibility for the correctness of the solution

Filename: Import of George Street-Station Lane.j9
Path: P:\22 Jobs\024-N Former BAE site, Birtley, Gateshead\Technical Assessments\Junctions9
Report generation date: 17/06/2022 16:14:17

- »2022 Baseline, AM
- »2022 Baseline, PM
- »2028 Baseline, AM
- »2028 Baseline, PM
- »2028 Baseline + CD + Dev, AM
- »2028 Baseline + CD + Dev, PM

Summary of junction performance

	AM						PM					
	Set ID	Queue (PCU)	Delay (s)	RFC	LOS	Network Residual Capacity	Set ID	Queue (PCU)	Delay (s)	RFC	LOS	Network Residual Capacity
2022 Baseline												
Stream B-AC	D1	0.0	8.45	0.03	A	216 %	D2	0.1	9.25	0.04	A	204 %
Stream C-AB		0.0	5.90	0.03	A	[Stream B-AC]		0.0	5.85	0.02	A	[Stream B-AC]
2028 Baseline												
Stream B-AC	D3	0.0	8.58	0.03	A	201 %	D4	0.1	9.47	0.05	A	188 %
Stream C-AB		0.1	5.86	0.03	A	[Stream B-AC]		0.0	5.82	0.03	A	[Stream B-AC]
2028 Baseline + CD + Dev												
Stream B-AC	D5	0.1	10.03	0.11	B	142 %	D6	0.1	9.92	0.08	A	157 %
Stream C-AB		0.1	5.89	0.04	A	[Stream B-AC]		0.1	5.91	0.05	A	[Stream B-AC]

Values shown are the highest values encountered over all time segments. Delay is the maximum value of average delay per arriving vehicle. Network Residual Capacity indicates the amount by which network flow could be increased before a user-definable threshold (see Analysis Options) is met.

File summary

File Description

Title	
Location	
Site number	
Date	27/04/2022
Version	
Status	(new file)
Identifier	
Client	
Jobnumber	
Enumerator	mtp\awreford
Description	

Units

Distance units	Speed units	Traffic units input	Traffic units results	Flow units	Average delay units	Total delay units	Rate of delay units
m	kph	PCU	PCU	perHour	s	-Min	perMin

Analysis Options

Vehicle length (m)	Calculate Queue Percentiles	Calculate detailed queueing delay	Calculate residual capacity	Residual capacity criteria type	RFC Threshold	Average Delay threshold (s)	Queue threshold (PCU)
5.75			✓	Delay	0.85	36.00	20.00

Demand Set Summary

ID	Scenario name	Time Period name	Traffic profile type	Start time (HH:mm)	Finish time (HH:mm)	Time segment length (min)	Run automatically
D1	2022 Baseline	AM	ONE HOUR	07:45	09:15	15	✓
D2	2022 Baseline	PM	ONE HOUR	16:45	18:15	15	✓
D3	2028 Baseline	AM	ONE HOUR	07:45	09:15	15	✓
D4	2028 Baseline	PM	ONE HOUR	16:45	18:15	15	✓
D5	2028 Baseline + CD + Dev	AM	ONE HOUR	07:45	09:15	15	✓
D6	2028 Baseline + CD + Dev	PM	ONE HOUR	16:45	18:15	15	✓

Analysis Set Details

ID	Include in report	Network flow scaling factor (%)	Network capacity scaling factor (%)
A1	✓	100.000	100.000

2022 Baseline, AM

Data Errors and Warnings

No errors or warnings

Junction Network

Junctions

Junction	Name	Junction type	Major road direction	Use circulating lanes	Junction Delay (s)	Junction LOS
1	untitled	T-Junction	Two-way		0.38	A

Junction Network Options

Driving side	Lighting	Network residual capacity (%)	First arm reaching threshold
Left	Normal/unknown	216	Stream B-AC

Arms

Arms

Arm	Name	Description	Arm type
A	Station Lane East		Major
B	George Street		Minor
C	Station Lane West		Major

Major Arm Geometry

Arm	Width of carriageway (m)	Has kerbed central reserve	Has right turn bay	Visibility for right turn (m)	Blocks?	Blocking queue (PCU)
Station Lane West	6.99			104.1	✓	0.00

Geometries for Arm C are measured opposite Arm B. Geometries for Arm A (if relevant) are measured opposite Arm D.

Minor Arm Geometry

Arm	Minor arm type	Lane width (m)	Visibility to left (m)	Visibility to right (m)
George Street	One lane	4.61	20	24

Slope / Intercept / Capacity

Priority Intersection Slopes and Intercepts

Stream	Intercept (PCU/hr)	Slope for A-B	Slope for A-C	Slope for C-A	Slope for C-B
B-A	576	0.100	0.254	0.160	0.363
B-C	742	0.109	0.275	-	-
C-B	634	0.235	0.235	-	-

The slopes and intercepts shown above do NOT include any corrections or adjustments.

Streams may be combined, in which case capacity will be adjusted.

Values are shown for the first time segment only; they may differ for subsequent time segments.

Traffic Demand

Demand Set Details

ID	Scenario name	Time Period name	Traffic profile type	Start time (HH:mm)	Finish time (HH:mm)	Time segment length (min)	Run automatically
D1	2022 Baseline	AM	ONE HOUR	07:45	09:15	15	✓

Vehicle mix varies over turn	Vehicle mix varies over entry	Vehicle mix source	PCU Factor for a HV (PCU)
✓	✓	HV Percentages	2.00

Demand overview (Traffic)

Arm	Linked arm	Profile type	Use O-D data	Average Demand (PCU/hr)	Scaling Factor (%)
Station Lane East		ONE HOUR	✓	315	100.000
George Street		ONE HOUR	✓	16	100.000
Station Lane West		ONE HOUR	✓	332	100.000

Origin-Destination Data

Demand (PCU/hr)

		To		
		Station Lane East	George Street	Station Lane West
From	Station Lane East	0	8	307
	George Street	8	0	8
	Station Lane West	320	12	0

Vehicle Mix

Heavy Vehicle Percentages

		To		
		Station Lane East	George Street	Station Lane West
From	Station Lane East	0	28	26
	George Street	18	0	16
	Station Lane West	22	18	0

Results

Results Summary for whole modelled period

Stream	Max RFC	Max Delay (s)	Max Queue (PCU)	Max LOS	Average Demand (PCU/hr)	Total Junction Arrivals (PCU)
B-AC	0.03	8.45	0.0	A	15	22
C-AB	0.03	5.90	0.0	A	18	27
C-A					286	430
A-B					7	11
A-C					282	423

Main Results for each time segment

07:45 - 08:00

Stream	Total Demand (PCU/hr)	Junction Arrivals (PCU)	Capacity (PCU/hr)	RFC	Throughput (PCU/hr)	Start queue (PCU)	End queue (PCU)	Delay (s)	Unsignalised level of service
B-AC	12	3	559	0.022	12	0.0	0.0	7.703	A
C-AB	13	3	742	0.018	13	0.0	0.0	5.892	A
C-A	237	59			237				
A-B	6	2			6				
A-C	231	58			231				

08:00 - 08:15

Stream	Total Demand (PCU/hr)	Junction Arrivals (PCU)	Capacity (PCU/hr)	RFC	Throughput (PCU/hr)	Start queue (PCU)	End queue (PCU)	Delay (s)	Unsignalised level of service
B-AC	14	4	541	0.027	14	0.0	0.0	7.999	A
C-AB	17	4	765	0.023	17	0.0	0.0	5.750	A
C-A	281	70			281				
A-B	7	2			7				
A-C	276	69			276				

08:15 - 08:30

Stream	Total Demand (PCU/hr)	Junction Arrivals (PCU)	Capacity (PCU/hr)	RFC	Throughput (PCU/hr)	Start queue (PCU)	End queue (PCU)	Delay (s)	Unsignalised level of service
B-AC	18	4	516	0.034	18	0.0	0.0	8.452	A
C-AB	24	6	797	0.030	24	0.0	0.0	5.569	A
C-A	342	85			342				
A-B	9	2			9				
A-C	338	85			338				

08:30 - 08:45

Stream	Total Demand (PCU/hr)	Junction Arrivals (PCU)	Capacity (PCU/hr)	RFC	Throughput (PCU/hr)	Start queue (PCU)	End queue (PCU)	Delay (s)	Unsignalised level of service
B-AC	18	4	516	0.034	18	0.0	0.0	8.452	A
C-AB	24	6	797	0.030	24	0.0	0.0	5.577	A
C-A	342	85			342				
A-B	9	2			9				
A-C	338	85			338				

08:45 - 09:00

Stream	Total Demand (PCU/hr)	Junction Arrivals (PCU)	Capacity (PCU/hr)	RFC	Throughput (PCU/hr)	Start queue (PCU)	End queue (PCU)	Delay (s)	Unsignalised level of service
B-AC	14	4	541	0.027	14	0.0	0.0	8.002	A
C-AB	17	4	765	0.023	17	0.0	0.0	5.763	A
C-A	281	70			281				
A-B	7	2			7				
A-C	276	69			276				

09:00 - 09:15

Stream	Total Demand (PCU/hr)	Junction Arrivals (PCU)	Capacity (PCU/hr)	RFC	Throughput (PCU/hr)	Start queue (PCU)	End queue (PCU)	Delay (s)	Unsignalised level of service
B-AC	12	3	559	0.022	12	0.0	0.0	7.706	A
C-AB	13	3	742	0.018	13	0.0	0.0	5.899	A
C-A	237	59			237				
A-B	6	2			6				
A-C	231	58			231				

2022 Baseline, PM

Data Errors and Warnings

No errors or warnings

Junction Network

Junctions

Junction	Name	Junction type	Major road direction	Use circulating lanes	Junction Delay (s)	Junction LOS
1	untitled	T-Junction	Two-way		0.43	A

Junction Network Options

Driving side	Lighting	Network residual capacity (%)	First arm reaching threshold
Left	Normal/unknown	204	Stream B-AC

Traffic Demand

Demand Set Details

ID	Scenario name	Time Period name	Traffic profile type	Start time (HH:mm)	Finish time (HH:mm)	Time segment length (min)	Run automatically
D2	2022 Baseline	PM	ONE HOUR	16:45	18:15	15	✓

Vehicle mix varies over turn	Vehicle mix varies over entry	Vehicle mix source	PCU Factor for a HV (PCU)
✓	✓	HV Percentages	2.00

Demand overview (Traffic)

Arm	Linked arm	Profile type	Use O-D data	Average Demand (PCU/hr)	Scaling Factor (%)
Station Lane East		ONE HOUR	✓	290	100.000
George Street		ONE HOUR	✓	19	100.000
Station Lane West		ONE HOUR	✓	330	100.000

Origin-Destination Data

Demand (PCU/hr)

		To		
		Station Lane East	George Street	Station Lane West
From	Station Lane East	0	5	285
	George Street	14	0	5
	Station Lane West	320	10	0

Vehicle Mix

Heavy Vehicle Percentages

		To		
		Station Lane East	George Street	Station Lane West
From	Station Lane East	0	28	26
	George Street	18	0	16
	Station Lane West	22	18	0

Results

Results Summary for whole modelled period

Stream	Max RFC	Max Delay (s)	Max Queue (PCU)	Max LOS	Average Demand (PCU/hr)	Total Junction Arrivals (PCU)
B-AC	0.04	9.25	0.1	A	17	26
C-AB	0.02	5.85	0.0	A	15	23
C-A					288	432
A-B					5	7
A-C					262	392

Main Results for each time segment

16:45 - 17:00

Stream	Total Demand (PCU/hr)	Junction Arrivals (PCU)	Capacity (PCU/hr)	RFC	Throughput (PCU/hr)	Start queue (PCU)	End queue (PCU)	Delay (s)	Unsignalised level of service
B-AC	14	4	521	0.027	14	0.0	0.0	8.345	A
C-AB	11	3	746	0.015	11	0.0	0.0	5.843	A
C-A	237	59			237				
A-B	4	0.94			4				
A-C	215	54			215				

17:00 - 17:15

Stream	Total Demand (PCU/hr)	Junction Arrivals (PCU)	Capacity (PCU/hr)	RFC	Throughput (PCU/hr)	Start queue (PCU)	End queue (PCU)	Delay (s)	Unsignalised level of service
B-AC	17	4	503	0.034	17	0.0	0.0	8.705	A
C-AB	14	4	769	0.019	14	0.0	0.0	5.693	A
C-A	282	71			282				
A-B	4	1			4				
A-C	256	64			256				

17:15 - 17:30

Stream	Total Demand (PCU/hr)	Junction Arrivals (PCU)	Capacity (PCU/hr)	RFC	Throughput (PCU/hr)	Start queue (PCU)	End queue (PCU)	Delay (s)	Unsignalised level of service
B-AC	21	5	478	0.044	21	0.0	0.1	9.253	A
C-AB	20	5	802	0.025	20	0.0	0.0	5.503	A
C-A	344	86			344				
A-B	6	1			6				
A-C	314	78			314				

17:30 - 17:45

Stream	Total Demand (PCU/hr)	Junction Arrivals (PCU)	Capacity (PCU/hr)	RFC	Throughput (PCU/hr)	Start queue (PCU)	End queue (PCU)	Delay (s)	Unsignalised level of service
B-AC	21	5	478	0.044	21	0.1	0.1	9.255	A
C-AB	20	5	802	0.025	20	0.0	0.0	5.510	A
C-A	344	86			344				
A-B	6	1			6				
A-C	314	78			314				

17:45 - 18:00

Stream	Total Demand (PCU/hr)	Junction Arrivals (PCU)	Capacity (PCU/hr)	RFC	Throughput (PCU/hr)	Start queue (PCU)	End queue (PCU)	Delay (s)	Unsignalised level of service
B-AC	17	4	503	0.034	17	0.1	0.0	8.707	A
C-AB	14	4	769	0.019	14	0.0	0.0	5.708	A
C-A	282	71			282				
A-B	4	1			4				
A-C	256	64			256				

18:00 - 18:15

Stream	Total Demand (PCU/hr)	Junction Arrivals (PCU)	Capacity (PCU/hr)	RFC	Throughput (PCU/hr)	Start queue (PCU)	End queue (PCU)	Delay (s)	Unsignalised level of service
B-AC	14	4	521	0.027	14	0.0	0.0	8.352	A
C-AB	11	3	746	0.015	11	0.0	0.0	5.852	A
C-A	237	59			237				
A-B	4	0.94			4				
A-C	215	54			215				

2028 Baseline, AM

Data Errors and Warnings

No errors or warnings

Junction Network

Junctions

Junction	Name	Junction type	Major road direction	Use circulating lanes	Junction Delay (s)	Junction LOS
1	untitled	T-Junction	Two-way		0.38	A

Junction Network Options

Driving side	Lighting	Network residual capacity (%)	First arm reaching threshold
Left	Normal/unknown	201	Stream B-AC

Traffic Demand

Demand Set Details

ID	Scenario name	Time Period name	Traffic profile type	Start time (HH:mm)	Finish time (HH:mm)	Time segment length (min)	Run automatically
D3	2028 Baseline	AM	ONE HOUR	07:45	09:15	15	✓

Vehicle mix varies over turn	Vehicle mix varies over entry	Vehicle mix source	PCU Factor for a HV (PCU)
✓	✓	HV Percentages	2.00

Demand overview (Traffic)

Arm	Linked arm	Profile type	Use O-D data	Average Demand (PCU/hr)	Scaling Factor (%)
Station Lane East		ONE HOUR	✓	331	100.000
George Street		ONE HOUR	✓	16	100.000
Station Lane West		ONE HOUR	✓	350	100.000

Origin-Destination Data

Demand (PCU/hr)

		To		
		Station Lane East	George Street	Station Lane West
From	Station Lane East	0	8	323
	George Street	8	0	8
	Station Lane West	337	13	0

Vehicle Mix

Heavy Vehicle Percentages

		To		
		Station Lane East	George Street	Station Lane West
From	Station Lane East	0	28	26
	George Street	18	0	16
	Station Lane West	22	18	0

Results

Results Summary for whole modelled period

Stream	Max RFC	Max Delay (s)	Max Queue (PCU)	Max LOS	Average Demand (PCU/hr)	Total Junction Arrivals (PCU)
B-AC	0.03	8.58	0.0	A	15	22
C-AB	0.03	5.86	0.1	A	20	30
C-A					301	451
A-B					7	11
A-C					296	445

Main Results for each time segment

07:45 - 08:00

Stream	Total Demand (PCU/hr)	Junction Arrivals (PCU)	Capacity (PCU/hr)	RFC	Throughput (PCU/hr)	Start queue (PCU)	End queue (PCU)	Delay (s)	Unsignalised level of service
B-AC	12	3	554	0.022	12	0.0	0.0	7.772	A
C-AB	15	4	748	0.020	15	0.0	0.0	5.856	A
C-A	249	62			249				
A-B	6	2			6				
A-C	243	61			243				

08:00 - 08:15

Stream	Total Demand (PCU/hr)	Junction Arrivals (PCU)	Capacity (PCU/hr)	RFC	Throughput (PCU/hr)	Start queue (PCU)	End queue (PCU)	Delay (s)	Unsignalised level of service
B-AC	14	4	535	0.027	14	0.0	0.0	8.089	A
C-AB	19	5	772	0.025	19	0.0	0.0	5.709	A
C-A	295	74			295				
A-B	7	2			7				
A-C	290	73			290				

08:15 - 08:30

Stream	Total Demand (PCU/hr)	Junction Arrivals (PCU)	Capacity (PCU/hr)	RFC	Throughput (PCU/hr)	Start queue (PCU)	End queue (PCU)	Delay (s)	Unsignalised level of service
B-AC	18	4	509	0.035	18	0.0	0.0	8.577	A
C-AB	27	7	807	0.033	27	0.0	0.1	5.523	A
C-A	359	90			359				
A-B	9	2			9				
A-C	356	89			356				

08:30 - 08:45

Stream	Total Demand (PCU/hr)	Junction Arrivals (PCU)	Capacity (PCU/hr)	RFC	Throughput (PCU/hr)	Start queue (PCU)	End queue (PCU)	Delay (s)	Unsignalised level of service
B-AC	18	4	509	0.035	18	0.0	0.0	8.577	A
C-AB	27	7	807	0.033	27	0.1	0.1	5.532	A
C-A	359	90			359				
A-B	9	2			9				
A-C	356	89			356				

08:45 - 09:00

Stream	Total Demand (PCU/hr)	Junction Arrivals (PCU)	Capacity (PCU/hr)	RFC	Throughput (PCU/hr)	Start queue (PCU)	End queue (PCU)	Delay (s)	Unsignalised level of service
B-AC	14	4	535	0.027	14	0.0	0.0	8.092	A
C-AB	19	5	772	0.025	19	0.1	0.0	5.725	A
C-A	295	74			295				
A-B	7	2			7				
A-C	290	73			290				

09:00 - 09:15

Stream	Total Demand (PCU/hr)	Junction Arrivals (PCU)	Capacity (PCU/hr)	RFC	Throughput (PCU/hr)	Start queue (PCU)	End queue (PCU)	Delay (s)	Unsignalised level of service
B-AC	12	3	554	0.022	12	0.0	0.0	7.773	A
C-AB	15	4	748	0.020	15	0.0	0.0	5.863	A
C-A	249	62			249				
A-B	6	2			6				
A-C	243	61			243				

2028 Baseline, PM

Data Errors and Warnings

No errors or warnings

Junction Network

Junctions

Junction	Name	Junction type	Major road direction	Use circulating lanes	Junction Delay (s)	Junction LOS
1	untitled	T-Junction	Two-way		0.44	A

Junction Network Options

Driving side	Lighting	Network residual capacity (%)	First arm reaching threshold
Left	Normal/unknown	188	Stream B-AC

Traffic Demand

Demand Set Details

ID	Scenario name	Time Period name	Traffic profile type	Start time (HH:mm)	Finish time (HH:mm)	Time segment length (min)	Run automatically
D4	2028 Baseline	PM	ONE HOUR	16:45	18:15	15	✓

Vehicle mix varies over turn	Vehicle mix varies over entry	Vehicle mix source	PCU Factor for a HV (PCU)
✓	✓	HV Percentages	2.00

Demand overview (Traffic)

Arm	Linked arm	Profile type	Use O-D data	Average Demand (PCU/hr)	Scaling Factor (%)
Station Lane East		ONE HOUR	✓	304	100.000
George Street		ONE HOUR	✓	20	100.000
Station Lane West		ONE HOUR	✓	347	100.000

Origin-Destination Data

Demand (PCU/hr)

		To		
		Station Lane East	George Street	Station Lane West
From	Station Lane East	0	5	299
	George Street	15	0	5
	Station Lane West	336	11	0

Vehicle Mix

Heavy Vehicle Percentages

		To		
		Station Lane East	George Street	Station Lane West
From	Station Lane East	0	28	26
	George Street	18	0	16
	Station Lane West	22	18	0

Results

Results Summary for whole modelled period

Stream	Max RFC	Max Delay (s)	Max Queue (PCU)	Max LOS	Average Demand (PCU/hr)	Total Junction Arrivals (PCU)
B-AC	0.05	9.47	0.1	A	18	28
C-AB	0.03	5.82	0.0	A	17	26
C-A					301	452
A-B					5	7
A-C					274	412

Main Results for each time segment

16:45 - 17:00

Stream	Total Demand (PCU/hr)	Junction Arrivals (PCU)	Capacity (PCU/hr)	RFC	Throughput (PCU/hr)	Start queue (PCU)	End queue (PCU)	Delay (s)	Unsignalised level of service
B-AC	15	4	514	0.029	15	0.0	0.0	8.475	A
C-AB	12	3	752	0.017	12	0.0	0.0	5.808	A
C-A	249	62			249				
A-B	4	0.94			4				
A-C	225	56			225				

17:00 - 17:15

Stream	Total Demand (PCU/hr)	Junction Arrivals (PCU)	Capacity (PCU/hr)	RFC	Throughput (PCU/hr)	Start queue (PCU)	End queue (PCU)	Delay (s)	Unsignalised level of service
B-AC	18	4	495	0.036	18	0.0	0.0	8.867	A
C-AB	16	4	776	0.021	16	0.0	0.0	5.655	A
C-A	296	74			296				
A-B	4	1			4				
A-C	269	67			269				

17:15 - 17:30

Stream	Total Demand (PCU/hr)	Junction Arrivals (PCU)	Capacity (PCU/hr)	RFC	Throughput (PCU/hr)	Start queue (PCU)	End queue (PCU)	Delay (s)	Unsignalised level of service
B-AC	22	6	469	0.047	22	0.0	0.1	9.469	A
C-AB	22	6	811	0.028	22	0.0	0.0	5.459	A
C-A	360	90			360				
A-B	6	1			6				
A-C	329	82			329				

17:30 - 17:45

Stream	Total Demand (PCU/hr)	Junction Arrivals (PCU)	Capacity (PCU/hr)	RFC	Throughput (PCU/hr)	Start queue (PCU)	End queue (PCU)	Delay (s)	Unsignalised level of service
B-AC	22	6	469	0.047	22	0.1	0.1	9.471	A
C-AB	22	6	811	0.028	22	0.0	0.0	5.465	A
C-A	360	90			360				
A-B	6	1			6				
A-C	329	82			329				

17:45 - 18:00

Stream	Total Demand (PCU/hr)	Junction Arrivals (PCU)	Capacity (PCU/hr)	RFC	Throughput (PCU/hr)	Start queue (PCU)	End queue (PCU)	Delay (s)	Unsignalised level of service
B-AC	18	4	495	0.036	18	0.1	0.0	8.869	A
C-AB	16	4	776	0.021	16	0.0	0.0	5.670	A
C-A	296	74			296				
A-B	4	1			4				
A-C	269	67			269				

18:00 - 18:15

Stream	Total Demand (PCU/hr)	Junction Arrivals (PCU)	Capacity (PCU/hr)	RFC	Throughput (PCU/hr)	Start queue (PCU)	End queue (PCU)	Delay (s)	Unsignalised level of service
B-AC	15	4	514	0.029	15	0.0	0.0	8.481	A
C-AB	13	3	752	0.017	13	0.0	0.0	5.818	A
C-A	249	62			249				
A-B	4	0.94			4				
A-C	225	56			225				

2028 Baseline + CD + Dev, AM

Data Errors and Warnings

No errors or warnings

Junction Network

Junctions

Junction	Name	Junction type	Major road direction	Use circulating lanes	Junction Delay (s)	Junction LOS
1	untitled	T-Junction	Two-way		0.86	A

Junction Network Options

Driving side	Lighting	Network residual capacity (%)	First arm reaching threshold
Left	Normal/unknown	142	Stream B-AC

Traffic Demand

Demand Set Details

ID	Scenario name	Time Period name	Traffic profile type	Start time (HH:mm)	Finish time (HH:mm)	Time segment length (min)	Run automatically
D5	2028 Baseline + CD + Dev	AM	ONE HOUR	07:45	09:15	15	✓

Vehicle mix varies over turn	Vehicle mix varies over entry	Vehicle mix source	PCU Factor for a HV (PCU)
✓	✓	HV Percentages	2.00

Demand overview (Traffic)

Arm	Linked arm	Profile type	Use O-D data	Average Demand (PCU/hr)	Scaling Factor (%)
Station Lane East		ONE HOUR	✓	338	100.000
George Street		ONE HOUR	✓	48	100.000
Station Lane West		ONE HOUR	✓	352	100.000

Origin-Destination Data

Demand (PCU/hr)

	To			
		Station Lane East	George Street	Station Lane West
From	Station Lane East	0	15	323
	George Street	32	0	16
	Station Lane West	337	15	0

Vehicle Mix

Heavy Vehicle Percentages

	To			
		Station Lane East	George Street	Station Lane West
From	Station Lane East	0	28	26
	George Street	18	0	16
	Station Lane West	22	18	0

Results

Results Summary for whole modelled period

Stream	Max RFC	Max Delay (s)	Max Queue (PCU)	Max LOS	Average Demand (PCU/hr)	Total Junction Arrivals (PCU)
B-AC	0.11	10.03	0.1	B	44	66
C-AB	0.04	5.89	0.1	A	23	35
C-A					300	449
A-B					14	21
A-C					296	445

Main Results for each time segment

07:45 - 08:00

Stream	Total Demand (PCU/hr)	Junction Arrivals (PCU)	Capacity (PCU/hr)	RFC	Throughput (PCU/hr)	Start queue (PCU)	End queue (PCU)	Delay (s)	Unsignalised level of service
B-AC	36	9	522	0.069	36	0.0	0.1	8.686	A
C-AB	17	4	747	0.023	17	0.0	0.0	5.883	A
C-A	248	62			248				
A-B	11	3			11				
A-C	243	61			243				

08:00 - 08:15

Stream	Total Demand (PCU/hr)	Junction Arrivals (PCU)	Capacity (PCU/hr)	RFC	Throughput (PCU/hr)	Start queue (PCU)	End queue (PCU)	Delay (s)	Unsignalised level of service
B-AC	43	11	502	0.086	43	0.1	0.1	9.206	A
C-AB	22	6	771	0.029	22	0.0	0.0	5.741	A
C-A	294	74			294				
A-B	13	3			13				
A-C	290	73			290				

08:15 - 08:30

Stream	Total Demand (PCU/hr)	Junction Arrivals (PCU)	Capacity (PCU/hr)	RFC	Throughput (PCU/hr)	Start queue (PCU)	End queue (PCU)	Delay (s)	Unsignalised level of service
B-AC	53	13	474	0.112	53	0.1	0.1	10.024	B
C-AB	31	8	805	0.038	31	0.0	0.1	5.563	A
C-A	357	89			357				
A-B	17	4			17				
A-C	356	89			356				

08:30 - 08:45

Stream	Total Demand (PCU/hr)	Junction Arrivals (PCU)	Capacity (PCU/hr)	RFC	Throughput (PCU/hr)	Start queue (PCU)	End queue (PCU)	Delay (s)	Unsignalised level of service
B-AC	53	13	474	0.112	53	0.1	0.1	10.030	B
C-AB	31	8	805	0.038	31	0.1	0.1	5.572	A
C-A	357	89			357				
A-B	17	4			17				
A-C	356	89			356				

08:45 - 09:00

Stream	Total Demand (PCU/hr)	Junction Arrivals (PCU)	Capacity (PCU/hr)	RFC	Throughput (PCU/hr)	Start queue (PCU)	End queue (PCU)	Delay (s)	Unsignalised level of service
B-AC	43	11	502	0.086	43	0.1	0.1	9.218	A
C-AB	22	6	771	0.029	22	0.1	0.0	5.758	A
C-A	294	74			294				
A-B	13	3			13				
A-C	290	73			290				

09:00 - 09:15

Stream	Total Demand (PCU/hr)	Junction Arrivals (PCU)	Capacity (PCU/hr)	RFC	Throughput (PCU/hr)	Start queue (PCU)	End queue (PCU)	Delay (s)	Unsignalised level of service
B-AC	36	9	522	0.069	36	0.1	0.1	8.702	A
C-AB	17	4	747	0.023	17	0.0	0.0	5.893	A
C-A	248	62			248				
A-B	11	3			11				
A-C	243	61			243				

2028 Baseline + CD + Dev, PM

Data Errors and Warnings

No errors or warnings

Junction Network

Junctions

Junction	Name	Junction type	Major road direction	Use circulating lanes	Junction Delay (s)	Junction LOS
1	untitled	T-Junction	Two-way		0.74	A

Junction Network Options

Driving side	Lighting	Network residual capacity (%)	First arm reaching threshold
Left	Normal/unknown	157	Stream B-AC

Traffic Demand

Demand Set Details

ID	Scenario name	Time Period name	Traffic profile type	Start time (HH:mm)	Finish time (HH:mm)	Time segment length (min)	Run automatically
D6	2028 Baseline + CD + Dev	PM	ONE HOUR	16:45	18:15	15	✓

Vehicle mix varies over turn	Vehicle mix varies over entry	Vehicle mix source	PCU Factor for a HV (PCU)
✓	✓	HV Percentages	2.00

Demand overview (Traffic)

Arm	Linked arm	Profile type	Use O-D data	Average Demand (PCU/hr)	Scaling Factor (%)
Station Lane East		ONE HOUR	✓	327	100.000
George Street		ONE HOUR	✓	35	100.000
Station Lane West		ONE HOUR	✓	354	100.000

Origin-Destination Data

Demand (PCU/hr)

	To			
	Station Lane East	George Street	Station Lane West	
From	Station Lane East	0	28	299
	George Street	26	0	9
	Station Lane West	336	18	0

Vehicle Mix

Heavy Vehicle Percentages

	To			
	Station Lane East	George Street	Station Lane West	
From	Station Lane East	0	28	26
	George Street	18	0	16
	Station Lane West	22	18	0

Results

Results Summary for whole modelled period

Stream	Max RFC	Max Delay (s)	Max Queue (PCU)	Max LOS	Average Demand (PCU/hr)	Total Junction Arrivals (PCU)
B-AC	0.08	9.92	0.1	A	32	48
C-AB	0.05	5.91	0.1	A	28	42
C-A					297	445
A-B					26	39
A-C					274	412

Main Results for each time segment

16:45 - 17:00

Stream	Total Demand (PCU/hr)	Junction Arrivals (PCU)	Capacity (PCU/hr)	RFC	Throughput (PCU/hr)	Start queue (PCU)	End queue (PCU)	Delay (s)	Unsignalised level of service
B-AC	26	7	512	0.052	26	0.0	0.1	8.705	A
C-AB	20	5	748	0.027	20	0.0	0.0	5.900	A
C-A	246	62			246				
A-B	21	5			21				
A-C	225	56			225				

17:00 - 17:15

Stream	Total Demand (PCU/hr)	Junction Arrivals (PCU)	Capacity (PCU/hr)	RFC	Throughput (PCU/hr)	Start queue (PCU)	End queue (PCU)	Delay (s)	Unsignalised level of service
B-AC	31	8	492	0.064	31	0.1	0.1	9.181	A
C-AB	27	7	772	0.035	27	0.0	0.1	5.765	A
C-A	292	73			292				
A-B	25	6			25				
A-C	269	67			269				

17:15 - 17:30

Stream	Total Demand (PCU/hr)	Junction Arrivals (PCU)	Capacity (PCU/hr)	RFC	Throughput (PCU/hr)	Start queue (PCU)	End queue (PCU)	Delay (s)	Unsignalised level of service
B-AC	39	10	465	0.083	38	0.1	0.1	9.920	A
C-AB	37	9	807	0.046	37	0.1	0.1	5.595	A
C-A	353	88			353				
A-B	31	8			31				
A-C	329	82			329				

17:30 - 17:45

Stream	Total Demand (PCU/hr)	Junction Arrivals (PCU)	Capacity (PCU/hr)	RFC	Throughput (PCU/hr)	Start queue (PCU)	End queue (PCU)	Delay (s)	Unsignalised level of service
B-AC	39	10	465	0.083	39	0.1	0.1	9.924	A
C-AB	37	9	807	0.046	37	0.1	0.1	5.602	A
C-A	353	88			353				
A-B	31	8			31				
A-C	329	82			329				

17:45 - 18:00

Stream	Total Demand (PCU/hr)	Junction Arrivals (PCU)	Capacity (PCU/hr)	RFC	Throughput (PCU/hr)	Start queue (PCU)	End queue (PCU)	Delay (s)	Unsignalised level of service
B-AC	31	8	492	0.064	32	0.1	0.1	9.189	A
C-AB	27	7	772	0.035	27	0.1	0.1	5.779	A
C-A	292	73			292				
A-B	25	6			25				
A-C	269	67			269				

18:00 - 18:15

Stream	Total Demand (PCU/hr)	Junction Arrivals (PCU)	Capacity (PCU/hr)	RFC	Throughput (PCU/hr)	Start queue (PCU)	End queue (PCU)	Delay (s)	Unsignalised level of service
B-AC	26	7	512	0.052	26	0.1	0.1	8.719	A
C-AB	21	5	748	0.027	21	0.1	0.0	5.908	A
C-A	246	61			246				
A-B	21	5			21				
A-C	225	56			225				

Appendix 13

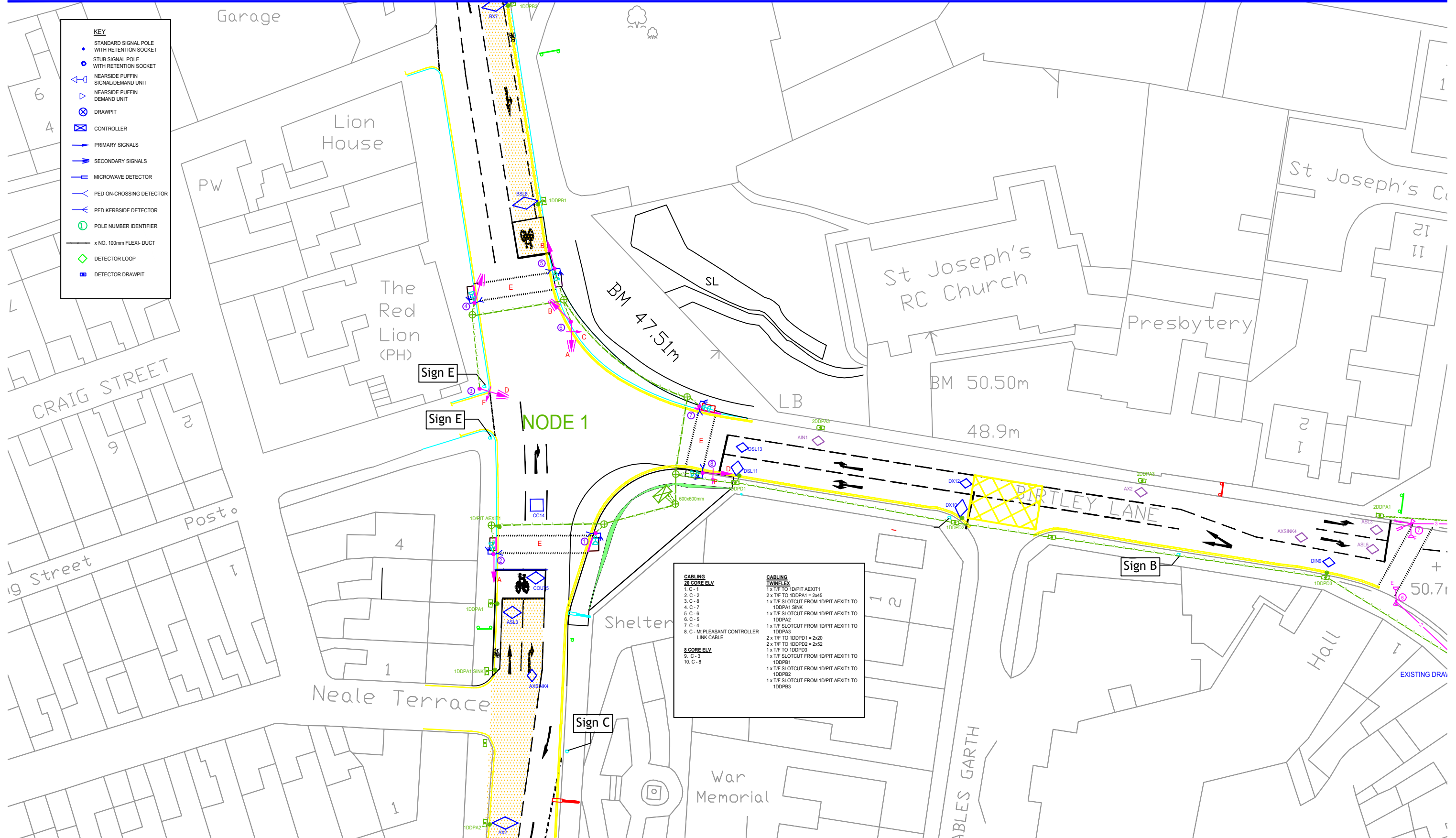

TECHNICAL SERVICES
 COMMUNITIES DIRECTORATE
 STRATFORD HOUSE
 NEWINGTON ROAD EAST
 NEWCASTLE UPON TYNE, NE2 1PX
 Tel.0191 2783832
 Fax.0191 2783805



DURHAM ROAD/BIRTLEY LANE
 TRAFFIC SIGNALS

MICK MURPHY B.Sc.(Hons) C.Eng. M.I.C.E.
 DIRECTOR OF COMMUNITIES

Rev	Amendments	Date	By	Scale	Date
A	D/PIT AND LOOP LABELS ADDED AND SOME DUCTS REMOVED	03/14	DBO	1:500	NOV-13
					Drawn DBO
					Prepared DBO
				Original Size A4	Checked TS
				Drawing No.	Revised
				TSG/4029/TS10065/1	A

Works Order :
EM Number : 4029
Engineer : D B Oliver
Intersection : Durham Road/Birtley Lane UTC - MOVA

Administration

General Specifications

Customer Name	<input type="text" value="Gateshead"/>	Customer Order No.	<input type="text"/>
Intersection/ General Description	<input type="text" value="Durham Road/Birtley Lane
UTC - MOVA"/>	Controller/ Serial Number	<input type="text"/>
Controller	<input checked="" type="radio"/> New <input type="radio"/> Modification	S.T.S. /EM Number	<input type="text" value="4029"/> Issue <input type="text" value="1"/>
Area Specifications/ Customer Drawings	<input type="text"/>	Equipment Installation by	<input type="text" value="TSG"/>
Specification Section	<input type="text"/>	Slot Cutting by	<input type="text" value="TSG"/>
Contract/Tender Ref.	<input type="text"/>	Civil Works by	<input type="text" value="Gateshead"/>
Quotation No.	<input type="text"/>	Customer's Engineer	<input type="text" value="ALow"/>
Works Order No.	<input type="text"/>	Telephone Number	<input type="text" value="01914333063"/>

Signal Company Use Only

Signal Engineer	<input type="text" value="DB Oliver"/>	(IF PROM Label as >) PROM Number	<input type="text" value="16260"/>	PROM Variant	<input type="text" value="0"/>
		Configuration Check Value	<input type="text" value="D6 31 F0 3A"/>		

Controller Options

Hardware Firmware Type and Issue Other Options

ST950/ST900/ST750 Series Cabinet Options

Cabinet/Rack Kit Type Options UK-Std Non-UK
Cabinet/Rack Variant Cuckoo Options Gemini Unit Fitted

Mains Supply	<input type="text" value="230"/> Volts	<input type="text" value="50"/> Hz					
Peak Lamp Current	<input type="text" value="2"/> Amps	Dimming Voltage	<input type="text" value="27.5"/>	Answer Issue	<input type="text" value="6"/>	Date Created	<input type="text" value="03/03/2014"/>
Average Lamp Power	<input type="text" value="273"/> Watts	Low Inrush Transformer	<input type="checkbox"/>	Edit Issue	<input type="text" value="3"/>		
Total Average Power	<input type="text" value="388"/> Watts						

Power feed fuse rating: requires 30 Amp minimum for controller, 15 Amp minimum for pelican/lightly loaded controller

Phases, Stages and Streams

Phases, Stages and Streams

Add/Delete/Insert Streams:

Streams	
<input checked="" type="radio"/>	Current Number of Streams <input type="text" value="1"/>

Phases	
<input type="radio"/>	Current Total Number of Phases <input type="text" value="6"/>
<input checked="" type="radio"/>	Number of Real Phases <input type="text" value="6"/>
<input type="radio"/>	Number of Dummy Phases <input type="text" value="0"/>

Stages	
<input type="radio"/>	Current Number of stages (inc.ALL-RED stages) <input type="text" value="5"/>

Switched Signs	
<input type="radio"/>	Number of Switched Signs <input type="text" value="0"/>

Action

<input type="button" value="AddAt"/>	<input type="button" value="DeleteAt"/>
--------------------------------------	---

Works Order :
 EM Number : 4029
 Engineer : D B Oliver
 Intersection : Durham Road/Birtley Lane UTC - MOVA

Facilities/Modes Enabled and Mode Priority Levels

Facilities

UTC

Serial/Internal UTMC OTU
 Free-standing OTU

Master Time Clock
 Holiday Clock
 FT To Current MAX
 Linked Fixed Time

Lamp Monitoring
 RED Lamp Monitoring
 Pelican/Puffin/Toucan
 Standalone Manual

ExtendAll Red
 Speed Measurement
 Ripple Change

Non-UK
 Fail to Part Time
 Fail To Hardware Flashing

Download To Level 3

Starting Intergreen

Mode Priority

	1	2	3	4	5	6	7	8	9	10	11	12	13
<input type="checkbox"/> Part Time	<input type="radio"/>	<input type="radio"/>	<input type="radio"/>	<input type="radio"/>	<input type="radio"/>	<input type="radio"/>	<input type="radio"/>	<input type="radio"/>	<input type="radio"/>	<input type="radio"/>	<input type="radio"/>	<input type="radio"/>	<input type="radio"/>
<input type="checkbox"/> Emergency Vehicles	<input type="radio"/>	<input type="radio"/>	<input type="radio"/>	<input type="radio"/>	<input type="radio"/>	<input type="radio"/>	<input type="radio"/>	<input type="radio"/>	<input type="radio"/>	<input type="radio"/>	<input type="radio"/>	<input type="radio"/>	<input type="radio"/>
<input checked="" type="checkbox"/> Hurry Call	<input type="radio"/>	<input type="radio"/>	<input type="radio"/>	<input checked="" type="radio"/>	<input type="radio"/>	<input type="radio"/>	<input type="radio"/>	<input type="radio"/>	<input type="radio"/>	<input type="radio"/>	<input type="radio"/>	<input type="radio"/>	<input type="radio"/>
<input type="checkbox"/> LRT	<input type="radio"/>	<input type="radio"/>	<input type="radio"/>	<input type="radio"/>	<input type="radio"/>	<input type="radio"/>	<input type="radio"/>	<input type="radio"/>	<input type="radio"/>	<input type="radio"/>	<input type="radio"/>	<input type="radio"/>	<input type="radio"/>
<input type="checkbox"/> Priority Vehicle	<input type="radio"/>	<input type="radio"/>	<input type="radio"/>	<input type="radio"/>	<input type="radio"/>	<input type="radio"/>	<input type="radio"/>	<input type="radio"/>	<input type="radio"/>	<input type="radio"/>	<input type="radio"/>	<input type="radio"/>	<input type="radio"/>
<input checked="" type="checkbox"/> Manual Control	<input checked="" type="radio"/>	<input type="radio"/>	<input type="radio"/>	<input type="radio"/>	<input type="radio"/>	<input type="radio"/>	<input type="radio"/>	<input type="radio"/>	<input type="radio"/>	<input type="radio"/>	<input type="radio"/>	<input type="radio"/>	<input type="radio"/>
<input type="checkbox"/> Manual Step On	<input type="radio"/>	<input type="radio"/>	<input type="radio"/>	<input type="radio"/>	<input type="radio"/>	<input type="radio"/>	<input type="radio"/>	<input type="radio"/>	<input type="radio"/>	<input type="radio"/>	<input type="radio"/>	<input type="radio"/>	<input type="radio"/>
<input checked="" type="checkbox"/> Selected FT or VA or CLF	<input type="radio"/>	<input type="radio"/>	<input type="radio"/>	<input type="radio"/>	<input checked="" type="radio"/>	<input type="radio"/>	<input type="radio"/>	<input type="radio"/>	<input type="radio"/>	<input type="radio"/>	<input type="radio"/>	<input type="radio"/>	<input type="radio"/>
<input checked="" type="checkbox"/> UTC	<input type="radio"/>	<input checked="" type="radio"/>	<input type="radio"/>	<input type="radio"/>	<input type="radio"/>	<input type="radio"/>	<input type="radio"/>	<input type="radio"/>	<input type="radio"/>	<input type="radio"/>	<input type="radio"/>	<input type="radio"/>	<input type="radio"/>
<input checked="" type="checkbox"/> MOVA Mode	<input type="radio"/>	<input type="radio"/>	<input checked="" type="radio"/>	<input type="radio"/>	<input type="radio"/>	<input type="radio"/>	<input type="radio"/>	<input type="radio"/>	<input type="radio"/>	<input type="radio"/>	<input type="radio"/>	<input type="radio"/>	<input type="radio"/>
<input type="checkbox"/> CLF (Non-Base Time)	<input type="radio"/>	<input type="radio"/>	<input type="radio"/>	<input type="radio"/>	<input type="radio"/>	<input type="radio"/>	<input type="radio"/>	<input type="radio"/>	<input type="radio"/>	<input type="radio"/>	<input type="radio"/>	<input type="radio"/>	<input type="radio"/>
<input checked="" type="checkbox"/> CLF (Base Time)	<input type="radio"/>	<input type="radio"/>	<input type="radio"/>	<input type="radio"/>	<input type="radio"/>	<input checked="" type="radio"/>	<input type="radio"/>	<input type="radio"/>	<input type="radio"/>	<input type="radio"/>	<input type="radio"/>	<input type="radio"/>	<input type="radio"/>
<input checked="" type="checkbox"/> Vehicle Actuated	<input type="radio"/>	<input type="radio"/>	<input type="radio"/>	<input type="radio"/>	<input type="radio"/>	<input type="radio"/>	<input checked="" type="radio"/>	<input type="radio"/>	<input type="radio"/>	<input type="radio"/>	<input type="radio"/>	<input type="radio"/>	<input type="radio"/>
<input checked="" type="checkbox"/> Fixed Time	<input type="radio"/>	<input type="radio"/>	<input type="radio"/>	<input type="radio"/>	<input type="radio"/>	<input type="radio"/>	<input type="radio"/>	<input checked="" type="radio"/>	<input type="radio"/>	<input type="radio"/>	<input type="radio"/>	<input type="radio"/>	<input type="radio"/>

Configuration Complexity

Low
 Medium
 High
 Maximum

Default PROM data file

Correspondence Monitoring to inc.

Reds
 Ambers
 Switched Signs
 Ignore Reds and Ambers during Fail

Flash Rate (ms)

Off
 On

Works Order :
EM Number : 4029
Engineer : D B Oliver
Intersection : Durham Road/Birtley Lane UTC - MOVA

Phases in Stages

Phases

	A	B	C	D	E	F
0						
1	■	■				
2	■		■			■
3				■		
4					■	

Works Order :
 EM Number : 4029
 Engineer : D B Oliver
 Intersection : Durham Road/Birtley Lane UTC - MOVA

Stages in Streams

Stages in Streams

	0	1	2	3	4	5	6	7
Phase or Stage to revert to in absence of demands/extensions	<input type="text" value="1"/>							
Startup Stage	<input type="text" value="1"/>							
Switch Off Stage	<input type="text" value="1"/>							
Standalone Pedestrian	<input type="checkbox"/>	<input type="checkbox"/>	<input type="checkbox"/>	<input type="checkbox"/>	<input type="checkbox"/>	<input type="checkbox"/>	<input type="checkbox"/>	<input type="checkbox"/>

Note: For a Stand-Alone Stream, the reversion must be to All Red stage or Traffic stage/phase to meet the relevant standard or specification.

Stages

	0	1	2	3	4
In Stream	<input checked="" type="checkbox"/>	<input checked="" type="checkbox"/>	<input checked="" type="checkbox"/>	<input checked="" type="checkbox"/>	<input checked="" type="checkbox"/>

Works Order :
 EM Number : 4029
 Engineer : D B Oliver
 Intersection : Durham Road/Birtley Lane UTC - MOVA

Phase Type and Conditions

Phase Type and Conditions

Phases A to P Manual Output Allocation Improved GA Appearance

Phase	Title	Type	App. Type	Term. Type	Assoc. Phase	No. of Drive Outputs		
						"R"	"A"	"G"
A	Durham Road Northbound	0 - UK Traffic	0	0 - E		1	1	1
B	Durham Road Southbound	0 - UK Traffic	0	0 - E		1	1	1
C	Durham Road Northbound Right Turn	2 - UK GreenArrow	0	2 - P	A	0	0	1
D	Birtley Lane	0 - UK Traffic	0	0 - E		1	1	1
E	Pedestrians	3 - UK Near Side Pedestrian	0	0 - E		2	2	4
F	Birtley Lane Left Turn Filter	2 - UK GreenArrow	0	1 - P	D	0	0	1

1) App Types: 0=Always Appears, 1=Appears if dem'd prior to interstage, 2= If dem'd, 3= If dem'd before end of window time
 2) Term Types: 0= Term's at end of stage, 1= Term's when Assoc phase gains R.O.W, 2= Term's when Assoc phase loses R.O.W.
 3) The H/W Fail Flash fields are for information only on all but ST900ELV Controllers. For other controllers, physical switches or links (etc.) select which aspects flash and these need to be set up manually.

Works Order :
 EM Number : 4029
 Engineer : D B Oliver
 Intersection : Durham Road/Birtley Lane UTC - MOVA

Opposing and Conflicting Phases

Select Stream(s) To Configure

All
 0

Initialise

Amber Conflict Monitoring

To Phase

	A	B	C	D	E	F
A		o	o	Co	Co	o
B	o		Co	Co	Co	Co
C	o	Co		Co	Co	o
D	Co	Co	Co		Co	o
E	Co	Co	Co	Co		Co
F	o	Co	o	o	Co	

From Phase

Works Order :
 EM Number : 4029
 Engineer : D B Oliver
 Intersection : Durham Road/Birtley Lane UTC - MOVA

Phase Minimums, Maximums, Extensions, Ped Leaving Periods

Phase Minimums, Maximums, Extensions, Ped Leaving Periods

Phases A to P

Phase	Min Green	Min Ped Clr	Extensions	Maximums								Pre-timed	
				A	B	C	D	E	F	G	H		
A	7	0	0.6	54	45	40	20	20	20	20	20	20	<input type="checkbox"/>
B	7	0	0.6	45	36	40	20	20	20	20	20	20	<input type="checkbox"/>
C	4	0	0.6	8	8	8	8	8	8	8	8	8	<input type="checkbox"/>
D	7	0	0.6	37	21	20	12	12	12	12	12	12	<input type="checkbox"/>
E	7	3	0.0	0	0	0	0	0	0	0	0	0	<input type="checkbox"/>
F	3	0	0.0	0	0	0	0	0	0	0	0	0	<input type="checkbox"/>
													<input type="checkbox"/>
													<input type="checkbox"/>
													<input type="checkbox"/>
													<input type="checkbox"/>
													<input type="checkbox"/>
													<input type="checkbox"/>
													<input type="checkbox"/>
													<input type="checkbox"/>
													<input type="checkbox"/>
													<input type="checkbox"/>
													<input type="checkbox"/>

Note: For Standalone Streams see Help for use of Max Sets.

Works Order :
 EM Number : 4029
 Engineer : D B Oliver
 Intersection : Durham Road/Birtley Lane UTC - MOVA

Phase Intergreen Times

Select Stream(s) To Configure

All
 0

Note: On a Stand Alone Pelican/Toucan/Puffin Stream the Intergreens between Pedestrian and Traffic Phases are controlled by the timings (PBT, PIT, CMX, CDY, CRD and PAR), therefore 0 should be entered for the appropriate intergreen times in grid below.

To Phase

		A	B	C	D	E	F
From Phase	A				6	11	
	B			8	6	11	6
	C		7		6	11	
	D	6	6	7		11	
	E	5	5	5	5		5
	F		6			11	

Works Order :
EM Number : 4029
Engineer : D B Oliver
Intersection : Durham Road/Birtley Lane UTC - MOVA

Intergreen Handset Limits

HIGH 199

Copy Intergreen Values

To Phase

	A	B	C	D	E	F
A				5	9	
B			5	6	8	
C		5		5	9	
D	5	5	5		8	
E	5	5	5	5		5
F					8	

Phase Timing Handset Ranges

Phase Timing Handset Ranges			
Initialise Min Green Limits			
Phase	Min. Green		Phase
	Min.	Max.	
A	<input type="text" value="3"/>	<input type="text" value="255"/>	Q
B	<input type="text" value="3"/>	<input type="text" value="255"/>	R
C	<input type="text" value="3"/>	<input type="text" value="255"/>	S
D	<input type="text" value="3"/>	<input type="text" value="255"/>	T
E	<input type="text" value="3"/>	<input type="text" value="255"/>	U
F	<input type="text" value="3"/>	<input type="text" value="255"/>	V
G			W
H			X
I			Y
J			Z
K			A2
L			B2
M			C2
N			D2
O			E2
P			F2

<table style="width: 100%;"> <tr> <th colspan="2" style="text-align: left; padding: 5px;">Max. Green</th> </tr> <tr> <td style="width: 50%; padding: 5px;">Min. <input type="text" value="0"/></td> <td style="width: 50%; padding: 5px;">Max. <input type="text" value="255"/></td> </tr> </table>	Max. Green		Min. <input type="text" value="0"/>	Max. <input type="text" value="255"/>	
Max. Green					
Min. <input type="text" value="0"/>	Max. <input type="text" value="255"/>				
<table style="width: 100%;"> <tr> <th colspan="2" style="text-align: left; padding: 5px;">Vehicle Extension</th> </tr> <tr> <td style="width: 50%; padding: 5px;">Min. <input type="text" value="0.0"/></td> <td style="width: 50%; padding: 5px;">Max. <input type="text" value="10.0"/></td> </tr> </table>	Vehicle Extension		Min. <input type="text" value="0.0"/>	Max. <input type="text" value="10.0"/>	
Vehicle Extension					
Min. <input type="text" value="0.0"/>	Max. <input type="text" value="10.0"/>				
<table style="width: 100%;"> <tr> <th colspan="2" style="text-align: left; padding: 5px;">Phase Delay</th> </tr> <tr> <td style="width: 50%; padding: 5px;">Min. <input type="text" value="2"/></td> <td style="width: 50%; padding: 5px;">Max. <input type="text" value="10"/></td> </tr> </table>	Phase Delay		Min. <input type="text" value="2"/>	Max. <input type="text" value="10"/>	
Phase Delay					
Min. <input type="text" value="2"/>	Max. <input type="text" value="10"/>				
<table style="width: 100%;"> <tr> <th colspan="2" style="text-align: left; padding: 5px;">Starting I/G</th> </tr> <tr> <td style="width: 50%; padding: 5px;">Min. <input type="text" value="4"/></td> <td style="width: 50%; padding: 5px;">Max. <input type="text" value="12"/></td> </tr> </table>	Starting I/G		Min. <input type="text" value="4"/>	Max. <input type="text" value="12"/>	
Starting I/G					
Min. <input type="text" value="4"/>	Max. <input type="text" value="12"/>				
<table style="width: 100%;"> <tr> <th colspan="2" style="text-align: left; padding: 5px;">Min Pedestrian Clearance (PBT)</th> </tr> <tr> <td style="width: 50%; padding: 5px;">Min. <input type="text" value="0"/></td> <td style="width: 50%; padding: 5px;">Max. <input type="text" value="12"/></td> </tr> </table>	Min Pedestrian Clearance (PBT)		Min. <input type="text" value="0"/>	Max. <input type="text" value="12"/>	
Min Pedestrian Clearance (PBT)					
Min. <input type="text" value="0"/>	Max. <input type="text" value="12"/>				
<table style="width: 100%;"> <tr> <th colspan="2" style="text-align: left; padding: 5px;">Traffic Phase Leaving</th> </tr> <tr> <td style="width: 50%; padding: 5px;">Min. <input type="text" value="3.0"/></td> <td style="width: 50%; padding: 5px;">Max. <input type="text" value="3.0"/></td> </tr> </table>	Traffic Phase Leaving		Min. <input type="text" value="3.0"/>	Max. <input type="text" value="3.0"/>	
Traffic Phase Leaving					
Min. <input type="text" value="3.0"/>	Max. <input type="text" value="3.0"/>				
<table style="width: 100%;"> <tr> <th colspan="2" style="text-align: left; padding: 5px;">Traffic Phase Red/Amber</th> </tr> <tr> <td style="width: 50%; padding: 5px;">Min. <input type="text" value="2"/></td> <td style="width: 50%; padding: 5px;">Max. <input type="text" value="2"/></td> </tr> </table>	Traffic Phase Red/Amber		Min. <input type="text" value="2"/>	Max. <input type="text" value="2"/>	
Traffic Phase Red/Amber					
Min. <input type="text" value="2"/>	Max. <input type="text" value="2"/>				

Works Order :
 EM Number : 4029
 Engineer : D B Oliver
 Intersection : Durham Road/Birtley Lane UTC - MOVA

VA Demand and Extend Definitions

VA Demand and Extend Definitions

Demands

For Unlatched demands precede the name with a #.
 Conditioning MUST be used to specify unlatched demands.

Phase	Demand 1	Demand 2	Demand 3	Demand 4
A	AX2	ASL3		
B	BX7	BSL8		
C				
D	DX10	DSL11	DX12	DSL13
E	1PBE	2PBE	4PBE	5PBE
F				

Phases A to P

Extensions

AX2	ASL3		
BX7	BSL8		
COU5	CC14		
DX10	DSL11	DX12	DSL13

Works Order :
 EM Number : 4029
 Engineer : D B Oliver
 Intersection : Durham Road/Birtley Lane UTC - MOVA

Phase Internal/Revertive Demands

Phase Internal/Revertive Demands

Start-up Vehicle Responsive Demands

A	<input checked="" type="checkbox"/>	B	<input checked="" type="checkbox"/>	C	<input checked="" type="checkbox"/>	D	<input checked="" type="checkbox"/>	E	<input checked="" type="checkbox"/>	F	<input checked="" type="checkbox"/>	<input type="checkbox"/>	<input type="checkbox"/>	<input type="checkbox"/>	<input type="checkbox"/>	<input type="checkbox"/>	<input type="checkbox"/>	<input type="checkbox"/>	<input type="checkbox"/>	<input type="checkbox"/>	<input type="checkbox"/>
<input type="checkbox"/>	<input type="checkbox"/>	<input type="checkbox"/>	<input type="checkbox"/>	<input type="checkbox"/>	<input type="checkbox"/>	<input type="checkbox"/>	<input type="checkbox"/>	<input type="checkbox"/>	<input type="checkbox"/>	<input type="checkbox"/>	<input type="checkbox"/>	<input type="checkbox"/>	<input type="checkbox"/>	<input type="checkbox"/>	<input type="checkbox"/>	<input type="checkbox"/>	<input type="checkbox"/>	<input type="checkbox"/>	<input type="checkbox"/>	<input type="checkbox"/>	<input type="checkbox"/>

Demands Inserted When Leaving Manual and Fixed Time Modes

A	<input checked="" type="checkbox"/>	B	<input checked="" type="checkbox"/>	C	<input checked="" type="checkbox"/>	D	<input checked="" type="checkbox"/>	E	<input checked="" type="checkbox"/>	F	<input checked="" type="checkbox"/>	<input type="checkbox"/>	<input type="checkbox"/>	<input type="checkbox"/>	<input type="checkbox"/>	<input type="checkbox"/>	<input type="checkbox"/>	<input type="checkbox"/>	<input type="checkbox"/>	<input type="checkbox"/>	<input type="checkbox"/>
<input type="checkbox"/>	<input type="checkbox"/>	<input type="checkbox"/>	<input type="checkbox"/>	<input type="checkbox"/>	<input type="checkbox"/>	<input type="checkbox"/>	<input type="checkbox"/>	<input type="checkbox"/>	<input type="checkbox"/>	<input type="checkbox"/>	<input type="checkbox"/>	<input type="checkbox"/>	<input type="checkbox"/>	<input type="checkbox"/>	<input type="checkbox"/>	<input type="checkbox"/>	<input type="checkbox"/>	<input type="checkbox"/>	<input type="checkbox"/>	<input type="checkbox"/>	<input type="checkbox"/>

Unlatched Demands that Start Max Timers

A	<input checked="" type="checkbox"/>	B	<input checked="" type="checkbox"/>	C	<input checked="" type="checkbox"/>	D	<input checked="" type="checkbox"/>	E	<input checked="" type="checkbox"/>	F	<input checked="" type="checkbox"/>	<input type="checkbox"/>	<input type="checkbox"/>	<input type="checkbox"/>	<input type="checkbox"/>	<input type="checkbox"/>	<input type="checkbox"/>	<input type="checkbox"/>	<input type="checkbox"/>	<input type="checkbox"/>	<input type="checkbox"/>
<input type="checkbox"/>	<input type="checkbox"/>	<input type="checkbox"/>	<input type="checkbox"/>	<input type="checkbox"/>	<input type="checkbox"/>	<input type="checkbox"/>	<input type="checkbox"/>	<input type="checkbox"/>	<input type="checkbox"/>	<input type="checkbox"/>	<input type="checkbox"/>	<input type="checkbox"/>	<input type="checkbox"/>	<input type="checkbox"/>	<input type="checkbox"/>	<input type="checkbox"/>	<input type="checkbox"/>	<input type="checkbox"/>	<input type="checkbox"/>	<input type="checkbox"/>	<input type="checkbox"/>

Revertive Phase Demands

A	B	C	D	E	F	G	H	I	J	K	L	M	N	O	P
<input type="text" value="A"/>	<input type="text" value="B"/>	<input type="text" value="A"/>	<input type="text" value="D"/>	<input type="text"/>	<input type="text"/>										
Q	R	S	T	U	V	W	X	Y	Z	A2	B2	C2	D2	E2	F2

Works Order :
EM Number : 4029
Engineer : D B Oliver
Intersection : Durham Road/Birtley Lane UTC - MOVA

Phase - On Crossing and Kerbside Detector Definitions

On Crossing and Kerbside Input Definitions

Phases AtoP

Phase	On Crossing				Kerbside			
A								
B								
C								
D								
E	1PCE	2PCE	4PCE	5PCE	1PKE	2PKE	4PKE	5PKE
F								

Works Order :
 EM Number : 4029
 Engineer : D B Oliver
 Intersection : Durham Road/Birtley Lane UTC - MOVA

Stream - Pelican/Puffin/Toucan Times

Stream - Pelican/Puffin/Toucan Times									
Pedestrian Enable VA Mode (PEV)									
	0	1	2	3	4	5	6	7	
Streams	0	1	2	3	4	5	6	7	
Pedestrian All Red Times (Vehicle to Pedestrian)									
(PAR n0) VA Gap Change									
(PAR n1) VA Max Change									
(PAR n2) FVP Change									
(PAR n3) UTC Change									
(PAR n4) Local Link Change									
Handset Range Limits									
									Min Max
									<input style="width: 40px; height: 20px;" type="text" value="0"/> <input style="width: 40px; height: 20px;" type="text" value="0"/>
Pelican Intergreen times									
(PIT n0) Veh Red/Ped Flash Green									<input style="width: 40px; height: 20px;" type="text" value="0"/> <input style="width: 40px; height: 20px;" type="text" value="0"/>
(PIT n1) Veh Flash Amber/Ped Flash Green									<input style="width: 40px; height: 20px;" type="text" value="0"/> <input style="width: 40px; height: 20px;" type="text" value="0"/>
(PIT n2) Veh Flash Amber/Ped red									<input style="width: 40px; height: 20px;" type="text" value="0"/> <input style="width: 40px; height: 20px;" type="text" value="0"/>
(PIT n3) Veh Flash Amber/Ped Red Quiescent									<input style="width: 40px; height: 20px;" type="text" value="0"/> <input style="width: 40px; height: 20px;" type="text" value="0"/>

Works Order :
 EM Number : 4029
 Engineer : D B Oliver
 Intersection : Durham Road/Birtley Lane UTC - MOVA

Phase - Pelican, Puffin and Toucan Times

Phase - Pelican, Puffin and Toucan Times

Phase	PDD Ped Demand Delay	PDX Ped Demand Hold	CMX Clearance Maximum	CDY0 Clearance Delay Gap Change	CDY1 Clearance Delay Max Change	CRD Clearance Minimum Red
A	<input type="text" value="0"/>	<input type="text" value="0.0"/>	<input type="text" value="0"/>	<input type="text" value="0"/>	<input type="text" value="0"/>	<input type="text" value="0"/>
B	<input type="text" value="0"/>	<input type="text" value="0.0"/>	<input type="text" value="0"/>	<input type="text" value="0"/>	<input type="text" value="0"/>	<input type="text" value="0"/>
C	<input type="text" value="0"/>	<input type="text" value="0.0"/>	<input type="text" value="0"/>	<input type="text" value="0"/>	<input type="text" value="0"/>	<input type="text" value="0"/>
D	<input type="text" value="0"/>	<input type="text" value="0.0"/>	<input type="text" value="0"/>	<input type="text" value="0"/>	<input type="text" value="0"/>	<input type="text" value="0"/>
E	<input type="text" value="0"/>	<input type="text" value="3.0"/>	<input type="text" value="11"/>	<input type="text" value="0"/>	<input type="text" value="0"/>	<input type="text" value="0"/>
F	<input type="text" value="0"/>	<input type="text" value="0.0"/>	<input type="text" value="0"/>	<input type="text" value="0"/>	<input type="text" value="0"/>	<input type="text" value="0"/>

Phases A to P

Pedestrian Handset Range Limits

	MIN	MAX
Demand Delay PDD	<input type="text" value="0"/>	<input type="text" value="6"/>
Demand Hold PDX	<input type="text" value="0.0"/>	<input type="text" value="6.0"/>
Clearance Maximum CMX	<input type="text" value="0"/>	<input type="text" value="20"/>
Clearance Delays CDY 0 and CDY1	<input type="text" value="0"/>	<input type="text" value="3"/>
Clearance Minimum Red CRD	<input type="text" value="0"/>	<input type="text" value="3"/>

Works Order :
EM Number : 4029
Engineer : D B Oliver
Intersection : Durham Road/Birtley Lane UTC - MOVA

IO and Link - Pelican/Puffin/Toucan Times

IO and Link - Pelican/Puffin/Toucan Times								
Streams	0	1	2	3	4	5	6	7
Computer Control								
PV								
Window Time UIE								
Local Link								
PV1								
Link Delay Time LKD								
Link Window Time LKW								
Link Override Time LKO								
Kerbside Mat Test <input type="checkbox"/>								
Output								

Works Order :
 EM Number : 4029
 Engineer : D B Oliver
 Intersection : Durham Road/Birtley Lane UTC - MOVA

Pelican, Puffin, Toucan Pushbutton/Kerbside Associations

Pelican, Puffin, Toucan Pushbutton/Kerbside Associations

	Phase	Demand	KBS		Phase	Demand	KBS		Phase	Demand	KBS		Phase	Demand	KBS
0	E	1PBE	1PKE	16				32				48			
1	E	2PBE	2PKE	17				33				49			
2	E	4PBE	4PKE	18				34				50			
3	E	5PBE	5PKE	19				35				51			
4				20				36				52			
5				21				37				53			
6				22				38				54			
7				23				39				55			
8				24				40				56			
9				25				41				57			
10				26				42				58			
11				27				43				59			
12				28				44				60			
13				29				45				61			
14				30				46				62			
15				31				47				63			

Note: Any association pushed off the screen will have any previous association blanked.

Works Order :
 EM Number : 4029
 Engineer : D B Oliver
 Intersection : Durham Road/Birtley Lane UTC - MOVA

Stages - Prohibited, Alternative, Ignored Moves

Stages - Prohibited, Alternative, Ignored Moves

Sets	Modes	Restrictions Apply To:	No Restrictions	Modes	Restrictions Apply To:	No Restrictions
<input checked="" type="radio"/> 1	Urban Traffic Control	<input checked="" type="radio"/>	<input type="radio"/>	Manual	<input checked="" type="radio"/>	<input type="radio"/>
<input type="radio"/> 2	Cableless Linking	<input checked="" type="radio"/>	<input type="radio"/>		<input type="radio"/>	<input type="radio"/>
<input type="radio"/> 3	Vehicle Actuated	<input checked="" type="radio"/>	<input type="radio"/>		<input type="radio"/>	<input type="radio"/>
<input type="radio"/> 4	Hurry Call	<input checked="" type="radio"/>	<input type="radio"/>		<input type="radio"/>	<input type="radio"/>
	Fixed Time	<input checked="" type="radio"/>	<input type="radio"/>	MOVA	<input checked="" type="radio"/>	<input type="radio"/>
		<input type="radio"/>	<input type="radio"/>			<input type="radio"/>

To Stage

	0	1	2	3	4
From Stage	0				
1					
2	3	3			3
3			1		
4			1		

Works Order :
EM Number : 4029
Engineer : D B Oliver
Intersection : Durham Road/Birtley Lane UTC - MOVA

Stage Internal Demands/Pedestrian Window Times

Stage Internal Demands/Pedestrian Window Times

Start-up Vehicle Responsive Demands

0	<input type="checkbox"/>	1	<input type="checkbox"/>	2	<input type="checkbox"/>	3	<input type="checkbox"/>	4	<input type="checkbox"/>	<input type="checkbox"/>	<input type="checkbox"/>	<input type="checkbox"/>	<input type="checkbox"/>	<input type="checkbox"/>	<input type="checkbox"/>	<input type="checkbox"/>	<input type="checkbox"/>	<input type="checkbox"/>	
	<input type="checkbox"/>		<input type="checkbox"/>		<input type="checkbox"/>		<input type="checkbox"/>		<input type="checkbox"/>		<input type="checkbox"/>		<input type="checkbox"/>		<input type="checkbox"/>		<input type="checkbox"/>		<input type="checkbox"/>

Demands Inserted When Leaving Manual and Fixed Time Modes

0	<input type="checkbox"/>	1	<input type="checkbox"/>	2	<input type="checkbox"/>	3	<input type="checkbox"/>	4	<input type="checkbox"/>	<input type="checkbox"/>	<input type="checkbox"/>	<input type="checkbox"/>	<input type="checkbox"/>	<input type="checkbox"/>	<input type="checkbox"/>	<input type="checkbox"/>	<input type="checkbox"/>	<input type="checkbox"/>	<input type="checkbox"/>
	<input type="checkbox"/>		<input type="checkbox"/>		<input type="checkbox"/>		<input type="checkbox"/>		<input type="checkbox"/>		<input type="checkbox"/>		<input type="checkbox"/>		<input type="checkbox"/>		<input type="checkbox"/>		<input type="checkbox"/>

Unlatched Demands that Start Maximum Timers

0	<input checked="" type="checkbox"/>	1	<input checked="" type="checkbox"/>	2	<input checked="" type="checkbox"/>	3	<input checked="" type="checkbox"/>	4	<input checked="" type="checkbox"/>	<input type="checkbox"/>	<input type="checkbox"/>	<input type="checkbox"/>	<input type="checkbox"/>	<input type="checkbox"/>	<input type="checkbox"/>	<input type="checkbox"/>	<input type="checkbox"/>	<input type="checkbox"/>	<input type="checkbox"/>
	<input type="checkbox"/>		<input type="checkbox"/>		<input type="checkbox"/>		<input type="checkbox"/>		<input type="checkbox"/>		<input type="checkbox"/>		<input type="checkbox"/>		<input type="checkbox"/>		<input type="checkbox"/>		<input type="checkbox"/>

Window Times

0	1	2	3	4	5	6	7	8	9	10	11	12	13	14	15
<input type="text" value="0"/>	<input type="text" value="0"/>	<input type="text" value="0"/>	<input type="text" value="0"/>	<input type="text" value="0"/>											
16	17	18	19	20	21	22	23	24	25	26	27	28	29	30	31

Exceptional Stages

0	<input type="checkbox"/>	1	<input type="checkbox"/>	2	<input type="checkbox"/>	3	<input type="checkbox"/>	4	<input type="checkbox"/>	<input type="checkbox"/>	<input type="checkbox"/>	<input type="checkbox"/>	<input type="checkbox"/>	<input type="checkbox"/>	<input type="checkbox"/>	<input type="checkbox"/>	<input type="checkbox"/>	<input type="checkbox"/>	<input type="checkbox"/>
	<input type="checkbox"/>		<input type="checkbox"/>		<input type="checkbox"/>		<input type="checkbox"/>		<input type="checkbox"/>		<input type="checkbox"/>		<input type="checkbox"/>		<input type="checkbox"/>		<input type="checkbox"/>		<input type="checkbox"/>

Works Order :
 EM Number : 4029
 Engineer : D B Oliver
 Intersection : Durham Road/Birtley Lane UTC - MOVA

Phase Delays

Phase Delays

Phase Delays 0-29

Phase Delays 30-59

Phase Delays 60-89

Phase Delays 90-119

No.	Delay Phase	On Change from Stage	To Stage	By (X) Seconds		No.	Delay Phase	On Change from Stage	To Stage	By (X) Seconds
0	A	1	3	1		15				0
1				0		16				0
2				0		17				0
3				0		18				0
4				0		19				0
5				0		20				0
6				0		21				0
7				0		22				0
8				0		23				0
9				0		24				0
10				0		25				0
11				0		26				0
12				0		27				0
13				0		28				0
14				0		29				0

Works Order :
 EM Number : 4029
 Engineer : D B Oliver
 Intersection : Durham Road/Birtley Lane UTC - MOVA

Fixed Time

Fixed Time

Stage Moves & Times (Not Fixed Time to Current Max)

Current Stage	0	1	2	3	4	5	6	7
Next Stage	<input type="text" value="1"/>	<input type="text" value="2"/>	<input type="text" value="3"/>	<input type="text" value="4"/>	<input type="text" value="1"/>			
Time	<input type="text" value="0"/>	<input type="text" value="40"/>	<input type="text" value="10"/>	<input type="text" value="20"/>	<input type="text" value="7"/>			
Current Stage	8	9	10	11	12	13	14	15
Next Stage								
Time								
Current Stage	16	17	18	19	20	21	22	23
Next Stage								
Time								
Current Stage	24	25	26	27	28	29	30	31
Next Stage								
Time								

Note:

Fixed Time mode may be used by the Reserve State, therefore, the Stage Moves and Times section should always be configured (unless Linked Fixed Time is selected instead).

Phases Demanded and Extended under Fixed Time to Current Max.

	A	B	C	D	E	F	G	H	I	J	K	L	M	N	O	P
Demand	<input checked="" type="checkbox"/>	<input checked="" type="checkbox"/>	<input checked="" type="checkbox"/>	<input checked="" type="checkbox"/>	<input type="checkbox"/>	<input type="checkbox"/>	<input type="checkbox"/>	<input type="checkbox"/>	<input type="checkbox"/>	<input type="checkbox"/>	<input type="checkbox"/>	<input type="checkbox"/>	<input type="checkbox"/>	<input type="checkbox"/>	<input type="checkbox"/>	<input type="checkbox"/>
Extend	<input checked="" type="checkbox"/>	<input checked="" type="checkbox"/>	<input checked="" type="checkbox"/>	<input checked="" type="checkbox"/>	<input type="checkbox"/>	<input type="checkbox"/>	<input type="checkbox"/>	<input type="checkbox"/>	<input type="checkbox"/>	<input type="checkbox"/>	<input type="checkbox"/>	<input type="checkbox"/>	<input type="checkbox"/>	<input type="checkbox"/>	<input type="checkbox"/>	<input type="checkbox"/>
	Q	R	S	T	U	V	W	X	Y	Z	A2	B2	C2	D2	E2	F2
Demand	<input type="checkbox"/>	<input type="checkbox"/>	<input type="checkbox"/>	<input type="checkbox"/>	<input type="checkbox"/>	<input type="checkbox"/>	<input type="checkbox"/>	<input type="checkbox"/>	<input type="checkbox"/>	<input type="checkbox"/>	<input type="checkbox"/>	<input type="checkbox"/>	<input type="checkbox"/>	<input type="checkbox"/>	<input type="checkbox"/>	<input type="checkbox"/>
Extend	<input type="checkbox"/>	<input type="checkbox"/>	<input type="checkbox"/>	<input type="checkbox"/>	<input type="checkbox"/>	<input type="checkbox"/>	<input type="checkbox"/>	<input type="checkbox"/>	<input type="checkbox"/>	<input type="checkbox"/>	<input type="checkbox"/>	<input type="checkbox"/>	<input type="checkbox"/>	<input type="checkbox"/>	<input type="checkbox"/>	<input type="checkbox"/>

Works Order :
 EM Number : 4029
 Engineer : D B Oliver
 Intersection : Durham Road/Birtley Lane UTC - MOVA

CLF - Plan(s)

CLF - Plan(s)

Plan No.

Copy From

Plan Specifics

Influence Set

Copy From

Entry Point (secs)

Exit Point (secs)

Cycle Time (secs)

Smooth CLF

Slow

Fast

Group Offset Handset Range

Min.

Max.

Group/Influence				CLF Influences			
Group No.	Group Offset	Group Influence	Related Stage	Group No.	Group Offset	Group Influence	Related Stage
0	70	2	2	16			
1	72	4	3	17			
2	81	1	3	18			
3	126	2	4	19			
4	128	1	1	20			
5				21			
6				22			
7				23			
8				24			
9				25			
10				26			
11				27			
12				28			
13				29			
14				30			
15				31			

CLF Influences

0- Go To VA

1- Immediate Move

2- Demand Dependent Move

3- Hold

4- Prevent Except To

5- Add Immediate Move

6- Add Demand Dependent Move

7- Ignore

8- Stand Alone Inhibited

9- Stand Alone Ped Allowed

Works Order :
 EM Number : 4029
 Engineer : D B Oliver
 Intersection : Durham Road/Birtley Lane UTC - MOVA

CLF - Plan(s)

CLF - Plan(s)		Group/Influence								CLF Influences
<input type="text" value="1"/>	Plan No.	Group No.	Group Offset	Group Influence	Related Stage	Group No.	Group Offset	Group Influence	Related Stage	
<input type="button" value="Copy From"/>		0	<input type="text" value="43"/>	<input type="text" value="2"/>	<input type="text" value="2"/>	16	<input type="text"/>	<input type="text"/>	<input type="text"/>	0- Go To VA
Plan Specifics		1	<input type="text" value="45"/>	<input type="text" value="4"/>	<input type="text" value="3"/>	17	<input type="text"/>	<input type="text"/>	<input type="text"/>	1- Immediate Move
<input type="text" value="1"/>	Influence Set	2	<input type="text" value="56"/>	<input type="text" value="1"/>	<input type="text" value="3"/>	18	<input type="text"/>	<input type="text"/>	<input type="text"/>	2- Demand Dependent Move
<input type="button" value="Copy From"/>		3	<input type="text" value="78"/>	<input type="text" value="2"/>	<input type="text" value="4"/>	19	<input type="text"/>	<input type="text"/>	<input type="text"/>	3- Hold
Entry Point (secs) <input type="text" value="255"/>		4	<input type="text" value="80"/>	<input type="text" value="1"/>	<input type="text" value="1"/>	20	<input type="text"/>	<input type="text"/>	<input type="text"/>	4- Prevent Except To
Exit Point (secs) <input type="text" value="255"/>		5	<input type="text"/>	<input type="text"/>	<input type="text"/>	21	<input type="text"/>	<input type="text"/>	<input type="text"/>	5- Add Immediate Move
Cycle Time (secs) <input type="text" value="88"/>		6	<input type="text"/>	<input type="text"/>	<input type="text"/>	22	<input type="text"/>	<input type="text"/>	<input type="text"/>	6- Add Demand Dependent Move
Smooth CLF		7	<input type="text"/>	<input type="text"/>	<input type="text"/>	23	<input type="text"/>	<input type="text"/>	<input type="text"/>	7- Ignore
Slow <input type="text" value="0"/>		8	<input type="text"/>	<input type="text"/>	<input type="text"/>	24	<input type="text"/>	<input type="text"/>	<input type="text"/>	8- Stand Alone Inhibited
Fast <input type="text" value="0"/>		9	<input type="text"/>	<input type="text"/>	<input type="text"/>	25	<input type="text"/>	<input type="text"/>	<input type="text"/>	9- Stand Alone Ped Allowed
Group Offset Handset Range		10	<input type="text"/>	<input type="text"/>	<input type="text"/>	26	<input type="text"/>	<input type="text"/>	<input type="text"/>	
Min. <input type="text" value="0"/>		11	<input type="text"/>	<input type="text"/>	<input type="text"/>	27	<input type="text"/>	<input type="text"/>	<input type="text"/>	
Max. <input type="text" value="255"/>		12	<input type="text"/>	<input type="text"/>	<input type="text"/>	28	<input type="text"/>	<input type="text"/>	<input type="text"/>	
		13	<input type="text"/>	<input type="text"/>	<input type="text"/>	29	<input type="text"/>	<input type="text"/>	<input type="text"/>	
		14	<input type="text"/>	<input type="text"/>	<input type="text"/>	30	<input type="text"/>	<input type="text"/>	<input type="text"/>	
		15	<input type="text"/>	<input type="text"/>	<input type="text"/>	31	<input type="text"/>	<input type="text"/>	<input type="text"/>	

Works Order :
 EM Number : 4029
 Engineer : D B Oliver
 Intersection : Durham Road/Birtley Lane UTC - MOVA

CLF - Plan(s)

CLF - Plan(s)		Group/Influence								CLF Influences
<input type="text" value="2"/>	Plan No.	Group No.	Group Offset	Group Influence	Related Stage	Group No.	Group Offset	Group Influence	Related Stage	
<input type="button" value="Copy From"/>		0	<input type="text" value="40"/>	<input type="text" value="2"/>	<input type="text" value="2"/>	16	<input type="text"/>	<input type="text"/>	<input type="text"/>	0- Go To VA
Plan Specifics		1	<input type="text" value="42"/>	<input type="text" value="4"/>	<input type="text" value="3"/>	17	<input type="text"/>	<input type="text"/>	<input type="text"/>	1- Immediate Move
<input type="text" value="2"/>	Influence Set	2	<input type="text" value="51"/>	<input type="text" value="1"/>	<input type="text" value="3"/>	18	<input type="text"/>	<input type="text"/>	<input type="text"/>	2- Demand Dependent Move
<input type="button" value="Copy From"/>		3	<input type="text" value="63"/>	<input type="text" value="2"/>	<input type="text" value="4"/>	19	<input type="text"/>	<input type="text"/>	<input type="text"/>	3- Hold
Entry Point (secs) <input type="text" value="255"/>		4	<input type="text" value="65"/>	<input type="text" value="1"/>	<input type="text" value="1"/>	20	<input type="text"/>	<input type="text"/>	<input type="text"/>	4- Prevent Except To
Exit Point (secs) <input type="text" value="255"/>		5	<input type="text"/>	<input type="text"/>	<input type="text"/>	21	<input type="text"/>	<input type="text"/>	<input type="text"/>	5- Add Immediate Move
Cycle Time (secs) <input type="text" value="70"/>		6	<input type="text"/>	<input type="text"/>	<input type="text"/>	22	<input type="text"/>	<input type="text"/>	<input type="text"/>	6- Add Demand Dependent Move
Smooth CLF		7	<input type="text"/>	<input type="text"/>	<input type="text"/>	23	<input type="text"/>	<input type="text"/>	<input type="text"/>	7- Ignore
Slow <input type="text" value="0"/>		8	<input type="text"/>	<input type="text"/>	<input type="text"/>	24	<input type="text"/>	<input type="text"/>	<input type="text"/>	8- Stand Alone Inhibited
Fast <input type="text" value="0"/>		9	<input type="text"/>	<input type="text"/>	<input type="text"/>	25	<input type="text"/>	<input type="text"/>	<input type="text"/>	9- Stand Alone Ped Allowed
Group Offset Handset Range		10	<input type="text"/>	<input type="text"/>	<input type="text"/>	26	<input type="text"/>	<input type="text"/>	<input type="text"/>	
Min. <input type="text" value="0"/>		11	<input type="text"/>	<input type="text"/>	<input type="text"/>	27	<input type="text"/>	<input type="text"/>	<input type="text"/>	
Max. <input type="text" value="255"/>		12	<input type="text"/>	<input type="text"/>	<input type="text"/>	28	<input type="text"/>	<input type="text"/>	<input type="text"/>	
		13	<input type="text"/>	<input type="text"/>	<input type="text"/>	29	<input type="text"/>	<input type="text"/>	<input type="text"/>	
		14	<input type="text"/>	<input type="text"/>	<input type="text"/>	30	<input type="text"/>	<input type="text"/>	<input type="text"/>	
		15	<input type="text"/>	<input type="text"/>	<input type="text"/>	31	<input type="text"/>	<input type="text"/>	<input type="text"/>	

Works Order :
EM Number : 4029
Engineer : D B Oliver
Intersection : Durham Road/Birtley Lane UTC - MOVA

CLF - Base Time

CLF - Base Time					
Controller Base Date		<input type="text" value="XX/XX/XX"/>			
Controller Base Time		<input type="text" value="00:00:00"/>			
Plan Offset					
	Minutes	Seconds		Minutes	Seconds
Plan 0	<input type="text" value="0"/>	<input type="text" value="0"/>	Plan 8	<input type="text" value="0"/>	<input type="text" value="0"/>
Plan 1	<input type="text" value="0"/>	<input type="text" value="0"/>	Plan 9	<input type="text" value="0"/>	<input type="text" value="0"/>
Plan 2	<input type="text" value="0"/>	<input type="text" value="0"/>	Plan 10	<input type="text" value="0"/>	<input type="text" value="0"/>
Plan 3	<input type="text" value="0"/>	<input type="text" value="0"/>	Plan 11	<input type="text" value="0"/>	<input type="text" value="0"/>
Plan 4	<input type="text" value="0"/>	<input type="text" value="0"/>	Plan 12	<input type="text" value="0"/>	<input type="text" value="0"/>
Plan 5	<input type="text" value="0"/>	<input type="text" value="0"/>	Plan 13	<input type="text" value="0"/>	<input type="text" value="0"/>
Plan 6	<input type="text" value="0"/>	<input type="text" value="0"/>	Plan 14	<input type="text" value="0"/>	<input type="text" value="0"/>
Plan 7	<input type="text" value="0"/>	<input type="text" value="0"/>	Plan 15	<input type="text" value="0"/>	<input type="text" value="0"/>
Handset Range Limits					
	Minutes	Seconds			
Min	<input type="text" value="0"/>	<input type="text" value="0"/>			
Max	<input type="text" value="255"/>	<input type="text" value="59"/>			

Works Order :
EM Number : 4029
Engineer : D B Oliver
Intersection : Durham Road/Birtley Lane UTC - MOVA

CLF - Demand Dependent Moves

Clear Grid Data

Notes:

If no data is entered for a stage then a demand for any phases in that stage will be considered. The data specified on this screen will also change the screen CLF - Demands to Consider with Demand Dependent Stage Moves.

Phases

	A	B	C	D	E	F
0						
1						
2						
3						
4						

Works Order :
EM Number : 4029
Engineer : D B Oliver
Intersection : Durham Road/Birtley Lane UTC - MOVA

UTC General Data

UTC General Data

Type of UTC

106

316

Integral OTU Address

Number of Control Words

Number of Reply Words

Controller to respond to TC bit.

Introduction of UTC to be disabled by Priority and LRT M

Non UTC RTC synchronisation input name

RTC Synchronisation Times

Clock Synchronise Time (UTC TS input)

Day

Time

Clock Confirm Time (UTC RT output)

Day

Time

Works Order :
 EM Number : 4029
 Engineer : D B Oliver
 Intersection : Durham Road/Birtley Lane UTC - MOVA

UTC Control and Reply Data Format

UTC Control and Reply Data Format

	Bit 1	Bit 2	Bit 3	Bit 4	Bit 5	Bit 6	Bit 7	Bit 8
Control Words								
Word 1	F1	#F2	#F3	#F4	D2	D3	D4	DX
Word 2	TS	GO						
Word 3								
Word 4								
Reply Words								
Word 1	G1	G2	G3	G4	SD2	SD3	SD4	DF
Word 2	CC	LO	LF1	LF2	LF3	MC	CF	MF0
Word 3	MLO							
Word 4								
Word 5								
Word 6								
Word 7								
Word 8								
Word 9								
Word 10								
Word 11								
Word 12								
Word 13								
Word 14								

Works Order :
 EM Number : 4029
 Engineer : D B Oliver
 Intersection : Durham Road/Birtley Lane UTC - MOVA

UTC Phase Demand and Extend Definitions

UTC Demand and Extend Definitions

Demands

For Unlatched demands, precede the name with a #.
 Conditioning MUST be used to specify unlatched demands.

Phase	Demand 1	Demand 2	Demand 3	Demand 4
A				
B				
C	D2	DX		
D	D3	DX		
E	D4			
F	D2			

Phases AtoP

Extensions

UTC Stage and Mode Data Definitions

UTC Stage and Mode Data Definitions

Stage	Force Bit	Green Confirm Bit	Demand Confirm Bit	Stage	Force Bit	Green Confirm Bit	Demand Confirm Bit
0				16			
1	F1	G1		17			
2	#F2	G2	SD2	18			
3	#F3	G3	SD3	19			
4	#F4	G4	SD4	20			
5				21			
6				22			
7				23			
8				24			
9				25			
10				26			
11				27			
12				28			
13				29			
14				30			
15				31			

Mode Data Definitions

Manual Mode Operative:
 G1/G2 RR

Manual Mode Selected:
 G1/G2 RR

No Lamp Power, or Lamps Off due to RLM or Part Time:
 G1/G2

Detector Fault:
 DF

Normal NOT selected on the Manual Panel:
 G1/G2 RR

RR Button Selected:
 G1/G2 RR

If UTC Reply Confirms are required for a Controller Fault (CF) OR for separate MC and RR replies, Conditioning must be used.

Works Order :
EM Number : 4029
Engineer : D B Oliver
Intersection : Durham Road/Birtley Lane UTC - MOVA

UTC Demand Dependent Forces

Clear Grid Data

Notes:

If no data is entered for a stage then a demand for any phases in that stage will be considered. The data specified on this screen will also change the screen CLF - Demands to Consider with Demand Dependent Stage Moves.

Phases

	A	B	C	D	E	F
0						
1						
2						
3						
4						

MOVA Stages

MOVA Stages

Stage	Force Bit	Green Confirm Bit	Stage	Force Bit	Green Confirm Bit
0			16		
1	MOVA0F1	MOVA0CON1	17		
2	MOVA0F2	MOVA0CON2	18		
3	MOVA0F3	MOVA0CON3	19		
4	MOVA0F4	MOVA0CON4	20		
5			21		
6			22		
7			23		
8			24		
9			25		
10			26		
11			27		
12			28		
13			29		
14			30		
15			31		

Mode Data Definitions

Manual Mode Operative:

G1/G2 RR/CRB

Manual Mode Selected:

G1/G2 RR/CRB

No Lamp Power, or Lamps Off due to RLM or Part Time:

G1/G2 RR/CRB

Normal NOT selected on the Manual Panel:

G1/G2 RR/CRB

RR Button Selected:

G1/G2 RR/CRB

Report as UTC Mode

MOVA Control Timer (x10)

MOVA Deactivate Timer

MOVA Release Timer

NOTE: If a MOVA Kernel does not map to the same numbered stream (0-3), refer to the help.

Works Order :
EM Number : 4029
Engineer : D B Oliver
Intersection : Durham Road/Birtley Lane UTC - MOVA

UTC and MOVA Detectors

UTC and MOVA Detectors

Detector Mapping
 Combined

Set Selection

1	AIN1	2	AX2	3	ASL3	4	AXSINK4	5	COUT5	6	BIN6	7	BX7	8	BSL8
9	DIN9	10	DX10	11	DSL11	12	DX12	13	DSL13	14	CC14	15		16	
17		18		19		20		21		22		23		24	
25		26		27		28		29		30		31		32	
33		34		35		36		37		38		39		40	
41		42		43		44		45		46		47		48	
49		50		51		52		53		54		55		56	
57		58		59		60		61		62		63		64	

Works Order :
 EM Number : 4029
 Engineer : D B Oliver
 Intersection : Durham Road/Birtley Lane UTC - MOVA

MTC - Time Switch Parameters

MTC - Time Switch Parameters

	Type	Event		Type	Event
0	Alternate Max	MAXSETB	16	No Action	
1	Alternate Max	MAXSETC	17	No Action	
2	Alternate Max	MAXSETD	18	No Action	
3	Alternate Max	MAXSETE	19	No Action	
4	Alternate Max	MAXSETF	20	No Action	
5	Alternate Max	MAXSETG	21	No Action	
6	Alternate Max	MAXSETH	22	No Action	
7	Conditioning	MTCF0	23	No Action	
8	Conditioning	MTCF1	24	No Action	
9	No Action		25	No Action	
10	No Action		26	No Action	
11	No Action		27	No Action	
12	No Action		28	No Action	
13	No Action		29	No Action	
14	No Action		30	No Action	
15	No Action		31	No Action	

Works Order :
 EM Number : 4029
 Engineer : D B Oliver
 Intersection : Durham Road/Birtley Lane UTC - MOVA

MTC - Timetable

MTC - Timetable

View Timetable Settings

0 - 15
 16 - 31
 32 - 47
 48 - 63

No.	Day Type	Time	Description	Function Code	Plan/Parameter
0	7	06:30:00	MAXSETA	2	0
1	7	09:30:00	MAXSETC	2	2
2	7	15:30:00	MAXSETB	2	1
3	7	19:00:00	MAXSETC	2	2
4	7	23:30:00	MAXSETD	2	3
5	7	07:00:00	MTCF0 SET	3	7
6	7	09:30:00	MTCF0 RESET	4	7
7	7	15:30:00	MTCF1 SET	3	8
8	7	19:00:00	MTCF1 RESET	4	8
9	7	07:00:00	CLF PLAN 0 (AMPEAK)	1	0
10	7	09:30:00	ISOLATE TO VA	0	0
11	7	15:30:00	CLF PLAN 1 (PMPEAK)	1	1
12	7	18:00:00	ISOLATE TO VA	0	0
13	0			0	0
14	0			0	0
15	0			0	0

Function Codes:

- 0 = Isolate From CLF
- 1 = Introduce a CLF Plan
- 2 = Introduce a Parameter (Combination of event switches)
- 3 = Selects an Individual event switch to be set
- 4 = Selects an Individual event switch to be cleared.

Works Order :
 EM Number : 4029
 Engineer : D B Oliver
 Intersection : Durham Road/Birtley Lane UTC - MOVA

Holiday Clock - Special Days

Holiday Clock - Special Days

0 - 15		
No.	Date	Day Type
0	<input type="text"/>	255
1	<input type="text"/>	255
2	<input type="text"/>	255
3	<input type="text"/>	255
4	<input type="text"/>	255
5	<input type="text"/>	255
6	<input type="text"/>	255
7	<input type="text"/>	255
8	<input type="text"/>	255
9	<input type="text"/>	255
10	<input type="text"/>	255
11	<input type="text"/>	255
12	<input type="text"/>	255
13	<input type="text"/>	255
14	<input type="text"/>	255
15	<input type="text"/>	255

16 - 31		
No.	Date	Day Type
16	<input type="text"/>	255
17	<input type="text"/>	255
18	<input type="text"/>	255
19	<input type="text"/>	255
20	<input type="text"/>	255
21	<input type="text"/>	255
22	<input type="text"/>	255
23	<input type="text"/>	255
24	<input type="text"/>	255
25	<input type="text"/>	255
26	<input type="text"/>	255
27	<input type="text"/>	255
28	<input type="text"/>	255
29	<input type="text"/>	255
30	<input type="text"/>	255
31	<input type="text"/>	255

32 - 47		
No.	Date	Day Type
32	<input type="text"/>	255
33	<input type="text"/>	255
34	<input type="text"/>	255
35	<input type="text"/>	255
36	<input type="text"/>	255
37	<input type="text"/>	255
38	<input type="text"/>	255
39	<input type="text"/>	255
40	<input type="text"/>	255
41	<input type="text"/>	255
42	<input type="text"/>	255
43	<input type="text"/>	255
44	<input type="text"/>	255
45	<input type="text"/>	255
46	<input type="text"/>	255
47	<input type="text"/>	255

48 - 63		
No.	Date	Day Type
48	<input type="text"/>	255
49	<input type="text"/>	255
50	<input type="text"/>	255
51	<input type="text"/>	255
52	<input type="text"/>	255
53	<input type="text"/>	255
54	<input type="text"/>	255
55	<input type="text"/>	255
56	<input type="text"/>	255
57	<input type="text"/>	255
58	<input type="text"/>	255
59	<input type="text"/>	255
60	<input type="text"/>	255
61	<input type="text"/>	255
62	<input type="text"/>	255
63	<input type="text"/>	255

Note 1 - Date format = dd/mm/yyyy

Note 2 - As 0 is a valid day type, 255 has been used as the day type default.

Works Order :
EM Number : 4029
Engineer : D B Oliver
Intersection : Durham Road/Birtley Lane UTC - MOVA

Holiday Clock - Special Holiday Periods

Holiday Clock - Special Holiday Periods

0 - 15			16 - 31		
No.	Start Date	End Date	No.	Start Date	End Date
0	<input type="text"/>	<input type="text"/>	16	<input type="text"/>	<input type="text"/>
1	<input type="text"/>	<input type="text"/>	17	<input type="text"/>	<input type="text"/>
2	<input type="text"/>	<input type="text"/>	18	<input type="text"/>	<input type="text"/>
3	<input type="text"/>	<input type="text"/>	19	<input type="text"/>	<input type="text"/>
4	<input type="text"/>	<input type="text"/>	20	<input type="text"/>	<input type="text"/>
5	<input type="text"/>	<input type="text"/>	21	<input type="text"/>	<input type="text"/>
6	<input type="text"/>	<input type="text"/>	22	<input type="text"/>	<input type="text"/>
7	<input type="text"/>	<input type="text"/>	23	<input type="text"/>	<input type="text"/>
8	<input type="text"/>	<input type="text"/>	24	<input type="text"/>	<input type="text"/>
9	<input type="text"/>	<input type="text"/>	25	<input type="text"/>	<input type="text"/>
10	<input type="text"/>	<input type="text"/>	26	<input type="text"/>	<input type="text"/>
11	<input type="text"/>	<input type="text"/>	27	<input type="text"/>	<input type="text"/>
12	<input type="text"/>	<input type="text"/>	28	<input type="text"/>	<input type="text"/>
13	<input type="text"/>	<input type="text"/>	29	<input type="text"/>	<input type="text"/>
14	<input type="text"/>	<input type="text"/>	30	<input type="text"/>	<input type="text"/>
15	<input type="text"/>	<input type="text"/>	31	<input type="text"/>	<input type="text"/>

Note - Date format = dd/mm/yyyy

Works Order :
EM Number : 4029
Engineer : D B Oliver
Intersection : Durham Road/Birtley Lane UTC - MOVA

LMU - General

LMU - General

Lamp Monitoring - LMU Voltage

48

Red Lamp Monitoring

Max Red Bulb Wattage RLF2 Cancels RLM additional Intergreens

First Red Lamp Fault Speed

RLF2 Only Cleared by RFL = 1

RLF1 Only Cleared by RFL = 1

RLM Additional Intergreen Handset Limits

Minimum	Maximum
<input type="text" value="2"/>	<input type="text" value="10"/>

Streams with Phase BlackOut on RLF2

0

Works Order :
 EM Number : 4029
 Engineer : D B Oliver
 Intersection : Durham Road/Birtley Lane UTC - MOVA

Integral LMU Onboard Sensors

Integral LMU Onboard Sensors

No. of LSLS cards fitted : 1
 HPU Connection : 1

Sensor Configuration For LSLS 1 (Cabinet 1)

Phase	Aspect	Sensor #	Sensor Type	Phase	Aspect	Sensor #	Sensor Type
A	Red	1	As Seq.	E	Green	N/A	
A	Amber	1	As Seq.	E	Green	N/A	
A	Green	1	As Seq.	F	Green	8	As Seq.
B	Red	2	As Seq.	N/A	N/A		
B	Amber	2	As Seq.	N/A	N/A		
B	Green	2	As Seq.	N/A	N/A		
C	Green	3	As Seq.	N/A	N/A		
D	Red	4	As Seq.	N/A	N/A		
D	Amber	4	As Seq.	N/A	N/A		
D	Green	4	As Seq.	N/A	N/A		
E	Red	5	R,G	N/A	N/A		
E	Red	6	R,G	N/A	N/A		
E	Amber	7	Wait	N/A	N/A		
E	Amber	7	Wait	N/A	N/A		
E	Green	5	R,G	N/A	N/A		
E	Green	6	R,G	N/A	N/A		

Note: A (*) character next to a sensor number indicates that the sensor would also be available on the External sensors screen. Please be sure you wish to use these sensors here, as they will then become unavailable for Regulatory Signs.

Works Order :
EM Number : 4029
Engineer : D B Oliver
Intersection : Durham Road/Birtley Lane UTC - MOVA

Integral LMU External Sensors for Regulatory Signs

Integral LMU External Sensors for Regulatory Signs

External Sensors (1)

Sensor	Sensor Type
96	Regulatory Sign
95	Regulatory Sign
94	Regulatory Sign
93	Regulatory Sign

External Sensors (4)

Sensor	Sensor Type
--------	-------------

External Sensors (2)

Sensor	Sensor Type
--------	-------------

External Sensors (5)

Sensor	Sensor Type
--------	-------------

External Sensors (3)

Sensor	Sensor Type
--------	-------------

External Sensors (6)

Sensor	Sensor Type
--------	-------------

Note: Sensors which have been used as Onboard sensors will not be available here.

Works Order :
 EM Number : 4029
 Engineer : D B Oliver
 Intersection : Durham Road/Birtley Lane UTC - MOVA

LMU Sensor Load Types

LMU Sensor Load Types

Screen Select: of 1

Sensor	Phase	Sensor Type	LED R+W	Load Type	LLF Profile
1	A	As Seq.	Auto	1: Siemens Helios ELV	
2	B	As Seq.	Auto	1: Siemens Helios ELV	
3	C	As Seq.	Auto	1: Siemens Helios ELV	
4	D	As Seq.	Auto	1: Siemens Helios ELV	
5	E	R,G	Auto	6: AGD LED Near Side Indicator	
6	E	R,G	Auto	7: AGD PED Demand Indicator	
7	E	Wait	Auto	1: Siemens Helios ELV	
8	F	As Seq.	Auto	1: Siemens Helios ELV	
93	N/A	Regulatory Sign	Auto	4: Siemens ELV Regulatory Sign	
94	N/A	Regulatory Sign	Auto	4: Siemens ELV Regulatory Sign	
95	N/A	Regulatory Sign	Auto	4: Siemens ELV Regulatory Sign	
96	N/A	Regulatory Sign	Auto	4: Siemens ELV Regulatory Sign	

Works Order :
EM Number : 4029
Engineer : D B Oliver
Intersection : Durham Road/Birtley Lane UTC - MOVA

RLM Additional Intergreens

Phases Delayed

	A	B	C	D	E	F
A					2	
B					2	
C						
D					2	
E						
F						

Works Order :
EM Number : 4029
Engineer : D B Oliver
Intersection : Durham Road/Birtley Lane UTC - MOVA

RLM Phase Inhibits

Phases Inhibited/Blacked-Out

	A	B	C	D	E	F
A					■	
B					■	
C						
D					■	
E						
F						

Works Order :
 EM Number : 4029
 Engineer : D B Oliver
 Intersection : Durham Road/Birtley Lane UTC - MOVA

Hurry Call

Hurry Call

Hurry Call	Stage Called	Call Input Name	Cancel Input Name	Confirm Output Name	Delay Time	Hold Time	Prevent Time
0	<input type="text" value="1"/>	<input type="text" value="*SCRT0"/>	<input type="text"/>	<input type="text"/>	<input type="text" value="0"/>	<input type="text" value="30"/>	<input type="text" value="150"/>
1	<input type="text" value="3"/>	<input type="text" value="*SCRT1"/>	<input type="text"/>	<input type="text"/>	<input type="text" value="0"/>	<input type="text" value="30"/>	<input type="text" value="150"/>
2	<input type="text"/>	<input type="text"/>	<input type="text"/>	<input type="text"/>	<input type="text" value="0"/>	<input type="text" value="0"/>	<input type="text" value="0"/>
3	<input type="text"/>	<input type="text"/>	<input type="text"/>	<input type="text"/>	<input type="text" value="0"/>	<input type="text" value="0"/>	<input type="text" value="0"/>
4	<input type="text"/>	<input type="text"/>	<input type="text"/>	<input type="text"/>	<input type="text" value="0"/>	<input type="text" value="0"/>	<input type="text" value="0"/>
5	<input type="text"/>	<input type="text"/>	<input type="text"/>	<input type="text"/>	<input type="text" value="0"/>	<input type="text" value="0"/>	<input type="text" value="0"/>
6	<input type="text"/>	<input type="text"/>	<input type="text"/>	<input type="text"/>	<input type="text" value="0"/>	<input type="text" value="0"/>	<input type="text" value="0"/>
7	<input type="text"/>	<input type="text"/>	<input type="text"/>	<input type="text"/>	<input type="text" value="0"/>	<input type="text" value="0"/>	<input type="text" value="0"/>

Hurry Call Limit Values		
	Min.	Max.
Call Delay	<input type="text" value="0"/>	<input type="text" value="255"/>
Call Hold	<input type="text" value="0"/>	<input type="text" value="255"/>
Call Prevent	<input type="text" value="0"/>	<input type="text" value="255"/>

Works Order :
 EM Number : 4029
 Engineer : D B Oliver
 Intersection : Durham Road/Birtley Lane UTC - MOVA

Manual Panel

Manual Panel

Stage Buttons and LEDs

Button No.	Title	Called Stage for Stream							
		0	1	2	3	4	5	6	7
0	ALL RED	0							
1	DURHAM ROAD	1							
2	DURHAM ROAD RIGHT TURN	2							
3	BIRTLEY LANE	3							
4	PEDESTRIANS	4							
5									
6									
7									

General LEDs

	AUX1	AUX2	AUX3	AUX4 (Hurry Call)	AUX5 (Higher Priority)
Conditioned	<input checked="" type="checkbox"/>	<input checked="" type="checkbox"/>	<input checked="" type="checkbox"/>	<input checked="" type="checkbox"/>	<input checked="" type="checkbox"/>

General Buttons

	None	SW1	SW2	SW3
Momentary		<input checked="" type="checkbox"/>	<input checked="" type="checkbox"/>	<input checked="" type="checkbox"/>
Dim Override	<input type="radio"/>	<input type="radio"/>	<input type="radio"/>	<input type="radio"/>
RR	<input type="radio"/>	<input type="radio"/>	<input type="radio"/>	<input type="radio"/>

Manual Signals On

- Immediate Signals On
 As Start-Up

Manual Mode Enable

- Always
 When Handset Plugged in (Note 1)
 When 'MND' Command Entered

NOTE:
 For this to operate Special
 Conditioning is required.

Mode Select Switches Disabled

- VA Fixed Time CLF

Works Order :
 EM Number : 4029
 Engineer : D B Oliver
 Intersection : Durham Road/Birtley Lane UTC - MOVA

Reserve State

Reserve State		Stream	0	1	2	3	4	5	6	7
Entry		Go to Switch Off Stage	<input type="checkbox"/>	<input type="checkbox"/>	<input type="checkbox"/>	<input type="checkbox"/>	<input type="checkbox"/>	<input type="checkbox"/>	<input type="checkbox"/>	<input type="checkbox"/>
Timeout (seconds)	Part Time on App Failure or Timeout		<input type="checkbox"/>	<input type="checkbox"/>	<input type="checkbox"/>	<input type="checkbox"/>	<input type="checkbox"/>	<input type="checkbox"/>	<input type="checkbox"/>	<input type="checkbox"/>
Limited Time		Fixed Time	<input checked="" type="radio"/>	<input checked="" type="radio"/>	<input checked="" type="radio"/>	<input checked="" type="radio"/>	<input checked="" type="radio"/>	<input checked="" type="radio"/>	<input checked="" type="radio"/>	<input checked="" type="radio"/>
Timeout (seconds)	Part Time		<input type="radio"/>	<input type="radio"/>	<input type="radio"/>	<input type="radio"/>	<input type="radio"/>	<input type="radio"/>	<input type="radio"/>	<input type="radio"/>
	Hold Stage		<input type="radio"/>	<input type="radio"/>	<input type="radio"/>	<input type="radio"/>	<input type="radio"/>	<input type="radio"/>	<input type="radio"/>	<input type="radio"/>
After Timeout		Fixed Time	<input checked="" type="radio"/>	<input checked="" type="radio"/>	<input checked="" type="radio"/>	<input checked="" type="radio"/>	<input checked="" type="radio"/>	<input checked="" type="radio"/>	<input checked="" type="radio"/>	<input checked="" type="radio"/>
	Part Time		<input type="radio"/>	<input type="radio"/>	<input type="radio"/>	<input type="radio"/>	<input type="radio"/>	<input type="radio"/>	<input type="radio"/>	<input type="radio"/>
	Hold Stage		<input type="radio"/>	<input type="radio"/>	<input type="radio"/>	<input type="radio"/>	<input type="radio"/>	<input type="radio"/>	<input type="radio"/>	<input type="radio"/>

Global Settings

Use Defaults

Timeouts

0 = Use Firmware default

Works Order :
EM Number : 4029
Engineer : D B Oliver
Intersection : Durham Road/Birtley Lane UTC - MOVA

Special Conditioning

```
;MOVA GENERAL CONDITIONING
;=====
;
;RUN MIN GREENS FOR 60s (COND TIMER 90) AFTER START-UP TO QUICK START MOVA .
;ALSO WHEN MAN PANEL PB AUX1 IS PRESSED TO ALLOW MOVA TO RE-LEARN STAGES IF NECESSARY
;=====
;
IFT ((PRVMOD0 EQL<8>) .NOT (MODE0 EQL<8>)) + (MAUXSW1) THN
RUN<90>
TRUE::: =+2SCRT0
    * =+LCST1
    * =+LCST2
    * =+LCST3
    * =+LCST4
END
NOT (CNDTER90+MOVATO) = .2SCRT0
2SCRT0::: =+LCPHA
    * =+LCPHB
    * =+LCPHC
    * =+LCPHD
    * =+LCPHE
2SCRT0 =+CLCONT
;
NOT (2SCRT0)::: =.EXOA
    * =.EXCA
    * =.EXOB
    * =.EXCB
    * =.EXOC
    * =.EXCC
    * =.EXOD
    * =.EXCD
;
2SCRT0 =.CLCONT
;
;1.4sec DUTY CYCLE ASTABLE TO ALLOW X DETECTOR PULSING
;=====
;
;SET CND TIMERS 91 to 1sec AND 92 TO 0.4sec
;-----
;
IFT (MODE0 EQL<8>) +CNDTER92 THN
RUN<91>
END
;
IFT CNDTER91 THN
RUN<92>
END
;-----
;
;PEDESTRIAN DEMANDS TO MOVADET INPUT TRANSLATION
;=====
;
PRSLMPAE .NOT (LMUINHE) =+MOVADET32
;
;-----
;
; MANUAL PANEL LED CONDITIONING
;=====
;
MODE0 EQL<6> + (MODE0 EQL<16> .CNDTMA91) =MIL17 ;HIGHER PRIORITY LED ON STEADY FOR UTC, FLASHING FOR MOVA
;
;-----
```

Works Order :
EM Number : 4029
Engineer : D B Oliver
Intersection : Durham Road/Birtley Lane UTC - MOVA

Special Conditioning

```
; PUFFIN/TOUCAN CONDITIONING FOR 6 ON CROSSING DETECTORS TO ACCOMODATE EXTRA TO FIRMWARE (2 No.)  
; ALTHOUGH ALL 6 ARE PROGRAMMED HERE, INCLUDING THE 4 ON CROSSING DETECTORS ALREADY ENTERED ON  
; APPROPRIATE SCREENS.  
; =====  
;  
;  
; Remember that it is still necessary to enter the names of at least one of the On Crossing  
; Detectors on the On Crossing and Kerbside Inputs Definition screen of IC4, otherwise  
; the Clearance will not be extendable. The name(s) entered on the On Crossing and Kerbside  
; Inputs Definition screen can be repeated in the Conditioning below, but do not need to be  
; as they are OR Stored.  
  
; ON CROSSING DETECTOR FAULT MONITORING  
; -----  
  
1PCE+=1SCRT32 ; ON CROSSING DETECTORS SET FLAGS TO  
2PCE+=1SCRT33 ; INDICATE THEY ARE WORKING.  
4PCE+=1SCRT34  
5PCE+=1SCRT35  
7PCE+=1SCRT36  
8PCE+=1SCRT37  
  
IFT (NOT(PBTTMAH+CMXTMAH).2SCRT1) THN ; HAS PED CLEARANCE (PBT) AND CMX TIME JUST TERMINATED?  
  
TRUE=1SCRT47 ; SET 'DETECTORS NOT ALL OPERATED' FLAG  
  
FALSE::::=1SCRT32 ; CLEAR 'ON CROSSING DETECTORS HAVE OPERATED' FLAGS  
 *=1SCRT33  
 *=1SCRT34  
 *=1SCRT35  
 *=1SCRT36  
 *=1SCRT37  
  
END  
  
; HAVE ALL ON CROSSING DETECTORS OPERATED DURING CONTROLLER CYCLE?  
; -----  
  
IFT (1SCRT32.1SCRT33.1SCRT34.1SCRT35.1SCRT36.1SCRT37) THN  
  
FALSE=1SCRT47 ; CLEAR 'DETECTORS NOT ALL OPERATED' FLAG  
  
END  
  
(PBTTMAH+CMXTMAH)=2SCRT1 ; PEDESTRIAN CLEARANCE TIME OR CMX TIME ACTIVE 200ms AGO  
  
; SET ON CROSSING ACTIVE FLAG TO EXTEND PED CLEARANCE TIME IF EITHER ONE OF THE ON CROSSING  
; DETECTORS IS ACTIVE OR ONE OF THE ON CROSSING DETECTOR INPUT EXTENSION TIMERS IS ACTIVE OR  
; THE FAULT FLAG IS SET INDICATING THAT ONE OF THE ON CROSSING DETECTORS DID NOT OPERATE DURING  
; THE PREVIOUS CONTROLLER CYCLE.  
; -----  
;  
;  
1PCE_ext+2PCE_ext+4PCE_ext+5PCE_ext+7PCE_ext+8PCE_ext+1SCRT47+=ONCACTE  
;  
; -----  
;  
; PUFFIN/TOUCAN CONDITIONING FOR 2 KERBSIDE DETECTORS ACCOMODATE EXTRA TO FIRMWARE  
; =====
```

Works Order :
EM Number : 4029
Engineer : D B Oliver
Intersection : Durham Road/Birtley Lane UTC - MOVA

Special Conditioning

```
; FOR AN ST900 CONTROLLER
; =====
;
; The following lines can be used in special conditioning to add pedestrian phase demand and kerbside
; inputs in addition to those provided by the firmware
;-----
;
7PBE_ext.7PKE_ext+=PBNACTE      ;Pushbutton and Kerbside both active

7PBE.NOT(7PKE_ext)=+PBNLATE     ;Pushbutton active while kerbside inactive
7PKE_ext+=KBSACTE              ;Kerbside extension active

8PBE_ext.8PKE_ext+=PBNACTE     ;Pushbutton and Kerbside both active

8PBE.NOT(8PKE_ext)=+PBNLATE     ;Pushbutton active while kerbside inactive
8PKE_ext+=KBSACTE              ;Kerbside extension active
;-----
;
;CLOCK SYNC BIT
;=====
(RTCTOD EQL<11>.RTCMIN EQL<59>.RTCSEC EQL<57>)+(RTCTOD EQL<11>.RTCMIN EQL<59>.RTCSEC EQL<59>)=CLCKSYNC
;
;-----
;
;QUEUE DETCTION LOGIC
;=====
;
;Queue on AIN1 or BIN6 approach priority calls stage 1
;Disabled by timetable flags MTCF0/MTCF1 or CFE0
;AIN1 disabled by DFM or CFE1
;BIN6 disabled by DFM or CFE2
;=====
;
(CCTO1.NOT(CFE1+AIN1_DFM))+ (CCTO2.NOT(CFE2+BIN6_DFM)).(MTCF0+MTCF1).NOT(STAGE1+NXTSTG0 EQL<1>+CFE0$
+1SCRT51+1SCRT54)=+1SCRT48
IFT 1SCRT48.NOT(1SCRT49) THN
RUN<0>
TRUE+=1SCRT50
TRUE+=1SCRT49
END
NOT(STAGE1):=.1SCRT48
          *=.1SCRT49
NOT(CNDTER0)=.1SCRT50
;
;
;Queue on phase D (DIN9) approach priority calls stage 3
;Disabled by timetable flags MTCF0/MTCF1 or CFE3
;=====
;
CCTO3.(MTCF0+MTCF1).NOT(DIN9_DFM+STAGE3+NXTSTG0 EQL<3>+CFE3+1SCRT48+1SCRT54)=+1SCRT51
IFT 1SCRT51.NOT(1SCRT52) THN
RUN<1>
TRUE+=1SCRT53
TRUE+=1SCRT52
END
NOT(STAGE3):=.1SCRT51
          *=.1SCRT52
NOT(CNDTER1)=.1SCRT53
;
;
;PRIORITY LOGIC
```

Works Order :
EM Number : 4029
Engineer : D B Oliver
Intersection : Durham Road/Birtley Lane UTC - MOVA

Special Conditioning

```
=====
1SCRT50.MODE0 EQL<6>=MOVADET21          ;PRIORITY MOVE TO STAGE 1
1SCRT50.MODE0 EQL<2>=SCRT0              ;DUE TO QUEUE ON AIN1 OR BIN6

;
1SCRT53.MODE0 EQL<6>=MOVADET22          ;PRIORITY MOVE TO STAGE 3
1SCRT53.MODE0 EQL<2>=SCRT1              ;DUE TO QUEUE ON DIN9
;
-----
;
;LINKING SIGNALS BETWEEN DURHAM RD/BIRTLEY LANE AND MOUNT PLEASANT CONTROLLERS
=====
;
;Confirm going to stage 1 forward link to Mount Pleasant
=====
NXTSTG0 EQL<1>.NOT(STAGE1)=TOST1
;
;Confirm going to stage 2 forward link to Mount Pleasant
=====
NXTSTG0 EQL<2>.NOT(STAGE2)=TOST2
;
;Confirm going to stage 3 forward link to Mount Pleasant
=====
NXTSTG0 EQL<3>.NOT(STAGE3)=TOST3
;
;Confirm going to stage 4 forward link to Mount Pleasant
=====
NXTSTG0 EQL<4>.NOT(STAGE4)=TOST4
-----
;
```

Works Order :
EM Number : 4029
Engineer : D B Oliver
Intersection : Durham Road/Birtley Lane UTC - MOVA

Special Conditioning

```
=====
;
;                               UTC REPLY BITS
;-----
; ;
NOT (MOVA0MF)=MF0 ;SET UP MF0 ( MOVA FAULT) UTC REPLY BIT FOR MOVA STREAM ZERO
;
NOT (MOVA0TO)=ML0 ; SET UP ML0 ( MOVA ON LINE) UTC REPLY BIT STREAM ZERO
;
NOT (FLF55)=LF1 ;SET UP 'LF1' (ANY LAMP FAILURE) UTC REPLY FOR ANY LAMP FAILURE
;
NOT (FLFCOM)=CF ;SET UP 'CF' (FAULT LOG ENTRY) UTC REPLY FOR FAULT LOG ENTRY
;
NOT (LMP1RED0+LMP1RED1+LMP1RED2+LMP1RED3)=LF2;SET UP 'LF2' (1ST RED FAILURE) UTC REPLY FOR 1ST RED LAMP FAILURE
;
NOT (LMP2RED0+LMP2RED1+LMP2RED2+LMP2RED3)=LF3;SET UP 'LF3' (2ND RED FAILURE) UTC REPLY FOR 2ND RED LAMP FAILURE
;
NOT (NTNORM)=MC ;SET UP 'MC' (NORMAL NOT SELECTED) UTC REPLY FOR NOT IN NORMAL
;
LMPON.NOT (FLF17)=LO ;SET UP 'LO' (SIGS OFF AT MANUAL PANEL OR NO LAMP SUPPLY) UTC REPLY FOR LAMPS OFF

MANSIGSW=.:G1 ;G1 AND G2 REPLY WITH SIGNALS OFF AT MANUAL PANEL
          *=.G2

=====
;
;                               GAP OUT LOGIC
;-----
IFT MODE0 EQL<6> THN
;
;GAP OUT FROM STAGE 1 TO STAGE 2
;-----
IFT F1.F2.GO.NOT (EXTAA+EXTAB) THN
FALSE=.F1
ELS
TRUE=.F1
END
;
;GAP OUT FROM STAGE 2 TO STAGE 3
;-----
IFT F2.F3.GO.NOT (EXTAC) THN
FALSE=.F2
ELS
TRUE=.F2
END
;
;GAP OUT FROM STAGE 3 TO STAGE 4
;-----
IFT F3.F4.GO.NOT (EXTAD) THN
FALSE=.F3
ELS
TRUE=.F3
END
;
;
;GAP OUT FROM STAGE 4 TO STAGE 1
;-----
IFT F1.F4.GO.NOT (EXTAE) THN
FALSE=.F4
ELS
TRUE=.F4
END
END
```

Works Order :
EM Number : 4029
Engineer : D B Oliver
Intersection : Durham Road/Birtley Lane UTC - MOVA

Special Conditioning

;

Works Order :
 EM Number : 4029
 Engineer : D B Oliver
 Intersection : Durham Road/Birtley Lane UTC - MOVA

Special Conditioning Timers

Special Conditioning Timers

Timers

0-31

No	Value	Min	Max	200ms	Description	No	Value	Min	Max	200ms	Description
0	3	2	6	<input checked="" type="checkbox"/>	MOVADET21 PULSE PR TO ST1	16		0	255	<input type="checkbox"/>	
1	3	2	6	<input checked="" type="checkbox"/>	MOVADET22 PULSE PR TO ST3	17		0	255	<input type="checkbox"/>	
2		0	255	<input type="checkbox"/>		18		0	255	<input type="checkbox"/>	
3		0	255	<input type="checkbox"/>		19		0	255	<input type="checkbox"/>	
4		0	255	<input type="checkbox"/>		20		0	255	<input type="checkbox"/>	
5		0	255	<input type="checkbox"/>		21		0	255	<input type="checkbox"/>	
6		0	255	<input type="checkbox"/>		22		0	255	<input type="checkbox"/>	
7		0	255	<input type="checkbox"/>		23		0	255	<input type="checkbox"/>	
8		0	255	<input type="checkbox"/>		24		0	255	<input type="checkbox"/>	
9		0	255	<input type="checkbox"/>		25		0	255	<input type="checkbox"/>	
10		0	255	<input type="checkbox"/>		26		0	255	<input type="checkbox"/>	
11		0	255	<input type="checkbox"/>		27		0	255	<input type="checkbox"/>	
12		0	255	<input type="checkbox"/>		28		0	255	<input type="checkbox"/>	
13		0	255	<input type="checkbox"/>		29		0	255	<input type="checkbox"/>	
14		0	255	<input type="checkbox"/>		30		0	255	<input type="checkbox"/>	
15		0	255	<input type="checkbox"/>		31		0	255	<input type="checkbox"/>	

Works Order :
 EM Number : 4029
 Engineer : D B Oliver
 Intersection : Durham Road/Birtley Lane UTC - MOVA

Special Conditioning Timers

Special Conditioning Timers

Timers

64-95

No	Value	Min	Max	200ms	Description	No	Value	Min	Max	200ms	Description
64		0	255	<input type="checkbox"/>		80		0	255	<input type="checkbox"/>	
65		0	255	<input type="checkbox"/>		81		0	255	<input type="checkbox"/>	
66		0	255	<input type="checkbox"/>		82		0	255	<input type="checkbox"/>	
67		0	255	<input type="checkbox"/>		83		0	255	<input type="checkbox"/>	
68		0	255	<input type="checkbox"/>		84		0	255	<input type="checkbox"/>	
69		0	255	<input type="checkbox"/>		85		0	255	<input type="checkbox"/>	
70		0	255	<input type="checkbox"/>		86		0	255	<input type="checkbox"/>	
71		0	255	<input type="checkbox"/>		87		0	255	<input type="checkbox"/>	
72		0	255	<input type="checkbox"/>		88		0	255	<input type="checkbox"/>	
73		0	255	<input type="checkbox"/>		89		0	255	<input type="checkbox"/>	
74		0	255	<input type="checkbox"/>		90	60	0	255	<input type="checkbox"/>	MOVA QUICK START
75		0	255	<input type="checkbox"/>		91	1	1	1	<input checked="" type="checkbox"/>	ASTABLE A
76		0	255	<input type="checkbox"/>		92	0.4	0	1	<input checked="" type="checkbox"/>	ASTABLE B
77		0	255	<input type="checkbox"/>		93		0	255	<input type="checkbox"/>	
78		0	255	<input type="checkbox"/>		94		0	255	<input type="checkbox"/>	
79		0	255	<input type="checkbox"/>		95		0	255	<input type="checkbox"/>	

Fault Log Flags

Fault Log Flags

Fault No	Cond Flag	Act Flag	Fault No	Cond Flag	Act Flag	Fault No	Cond Flag	Act Flag	Fault No	Cond Flag	Act Flag
0	<input checked="" type="checkbox"/>	<input type="checkbox"/>	16	<input checked="" type="checkbox"/>	<input type="checkbox"/>	32	<input checked="" type="checkbox"/>	<input type="checkbox"/>	48	<input checked="" type="checkbox"/>	<input type="checkbox"/>
1	<input checked="" type="checkbox"/>	<input type="checkbox"/>	17	<input type="checkbox"/>	<input type="checkbox"/>	33	<input checked="" type="checkbox"/>	<input type="checkbox"/>	49	<input checked="" type="checkbox"/>	<input type="checkbox"/>
2	<input checked="" type="checkbox"/>	<input type="checkbox"/>	18	<input checked="" type="checkbox"/>	<input type="checkbox"/>	34	<input checked="" type="checkbox"/>	<input type="checkbox"/>	50	<input checked="" type="checkbox"/>	<input type="checkbox"/>
3	<input checked="" type="checkbox"/>	<input type="checkbox"/>	19	<input checked="" type="checkbox"/>	<input type="checkbox"/>	35	<input checked="" type="checkbox"/>	<input type="checkbox"/>	51	<input checked="" type="checkbox"/>	<input type="checkbox"/>
4	<input checked="" type="checkbox"/>	<input type="checkbox"/>	20	<input checked="" type="checkbox"/>	<input type="checkbox"/>	36	<input checked="" type="checkbox"/>	<input type="checkbox"/>	52	<input checked="" type="checkbox"/>	<input type="checkbox"/>
5	<input checked="" type="checkbox"/>	<input type="checkbox"/>	21	<input checked="" type="checkbox"/>	<input type="checkbox"/>	37	<input checked="" type="checkbox"/>	<input type="checkbox"/>	53	<input checked="" type="checkbox"/>	<input type="checkbox"/>
6	<input checked="" type="checkbox"/>	<input type="checkbox"/>	22	<input type="checkbox"/>	<input type="checkbox"/>	38	<input checked="" type="checkbox"/>	<input type="checkbox"/>	54	<input checked="" type="checkbox"/>	<input type="checkbox"/>
7	<input checked="" type="checkbox"/>	<input type="checkbox"/>	23	<input checked="" type="checkbox"/>	<input type="checkbox"/>	39	<input checked="" type="checkbox"/>	<input type="checkbox"/>	55	<input type="checkbox"/>	<input type="checkbox"/>
8	<input checked="" type="checkbox"/>	<input type="checkbox"/>	24	<input checked="" type="checkbox"/>	<input type="checkbox"/>	40	<input checked="" type="checkbox"/>	<input type="checkbox"/>	56	<input checked="" type="checkbox"/>	<input type="checkbox"/>
9	<input checked="" type="checkbox"/>	<input type="checkbox"/>	25	<input checked="" type="checkbox"/>	<input type="checkbox"/>	41	<input checked="" type="checkbox"/>	<input type="checkbox"/>	57	<input checked="" type="checkbox"/>	<input type="checkbox"/>
10	<input checked="" type="checkbox"/>	<input type="checkbox"/>	26	<input checked="" type="checkbox"/>	<input type="checkbox"/>	42	<input checked="" type="checkbox"/>	<input type="checkbox"/>	58	<input checked="" type="checkbox"/>	<input type="checkbox"/>
11	<input checked="" type="checkbox"/>	<input type="checkbox"/>	27	<input checked="" type="checkbox"/>	<input type="checkbox"/>	43	<input checked="" type="checkbox"/>	<input type="checkbox"/>	59	<input checked="" type="checkbox"/>	<input type="checkbox"/>
12	<input type="checkbox"/>	<input type="checkbox"/>	28	<input checked="" type="checkbox"/>	<input type="checkbox"/>	44	<input checked="" type="checkbox"/>	<input type="checkbox"/>	60	<input checked="" type="checkbox"/>	<input type="checkbox"/>
13	<input checked="" type="checkbox"/>	<input type="checkbox"/>	29	<input checked="" type="checkbox"/>	<input type="checkbox"/>	45	<input checked="" type="checkbox"/>	<input type="checkbox"/>	61	<input checked="" type="checkbox"/>	<input type="checkbox"/>
14	<input checked="" type="checkbox"/>	<input type="checkbox"/>	30	<input checked="" type="checkbox"/>	<input type="checkbox"/>	46	<input checked="" type="checkbox"/>	<input type="checkbox"/>	62	<input checked="" type="checkbox"/>	<input type="checkbox"/>
15	<input checked="" type="checkbox"/>	<input type="checkbox"/>	31	<input checked="" type="checkbox"/>	<input type="checkbox"/>	47	<input checked="" type="checkbox"/>	<input type="checkbox"/>	63	<input checked="" type="checkbox"/>	<input type="checkbox"/>

Note:

Cond Flag -
 If a fault occurs which sets a fault log flag that has been checked for this Cond flag option then a flag will be set that can be read in Conditioning.

Act Flag -
 If a fault occurs which sets a fault log flag that has been checked for this Act flag option then firstly the lamps will be switched OFF and secondly a flag will be set that can be read in conditioning, to allow any further actions required to be performed by conditioning.

Clearance of Special Condition

Works Order :
EM Number : 4029
Engineer : D B Oliver
Intersection : Durham Road/Birtley Lane UTC - MOVA

Special Instructions

4029

Card Type	Rack Posn	Addr.	Port	Type	Line	Term Posn
Intelligent Backplane 16/0	Rack	01	0	I	000 - 007	2 LT1
Intelligent Backplane 16/0	Rack	01	1	I	008 - 015	2 LT1
Serial IO 24/16	1 I/O1	02	2	I	016 - 023	1 I/O1
Serial IO 24/16	1 I/O1	02	3	I	024 - 031	1 I/O1
Serial IO 24/16	1 I/O1	02	4	I	032 - 039	1 I/O1
Serial IO 24/16	1 I/O1	02	5	O	040 - 047	1 I/O1
Serial IO 24/16	1 I/O1	02	6	O	048 - 055	1 I/O1
CPU	A					

Works Order :
 EM Number : 4029
 Engineer : D B Oliver
 Intersection : Durham Road/Birtley Lane UTC - MOVA

Special Instructions

ST900 ELV CONTROLLER ITEMS LIST SHEET 1 (*I*L*)

ITEM	DRAWING NUMBER	DESCRIPTION	QTY	TOT	REMARKS
1					
2	667/1/32900/020	ST900 ELV Cabinet UK 20A 1 LSLS - Grey			
3	667/1/32900/040	ST900 ELV Cabinet UK 40A 1 LSLS - Grey			
4	667/1/32900/021	ST900 ELV Cabinet UK 20A 1 LSLS - Black	1		
5	667/1/32900/041	ST900 ELV Cabinet UK 40A 1 LSLS - Black			
6	667/1/32900/520	ST900ELV 20A SGL LSLS LOW INRUSH - Grey			
7	667/1/32900/521	ST900ELV 20A SGL LSLS LOW INRUSH - Black			
8					
9	667/1/32943/001	ELV Lamp switch (LSLS) kit			
10	667/1/32960/001	ELV Lamp switch (LSLS) backplane kit			
11	667/1/32995/002	ST900 I/O card kit (4 outputs)			
12	667/1/32995/001	ST900 I/O card kit (16 outputs)	1		
13					
14					
15					
16	667/1/27004/000	Integral TC12 OTU kit			
17	667/1/27005/000	SDE Facility kit			
18	667/1/32910/000	ST900 Intelligent detector backplane kit	1		
19	667/1/33002/000	ELV detector 6U rack expansion kit			
20	667/1/33074/000	ST900 ELV 24 V detector supply Kit (6A)			
21	667/1/20690/001	19" Detector Rack			
22					
23	667/1/32980/040	ELV 20A to 40A upgrade kit			
24					
25					
26	667/1/33070/000	ELV Regulatory Sign expansion kit			
27	667/1/32955/000	ELV Audible supply kit			
28	667/1/27117/000	ST900 300mA RCD kit			
29					
30	667/1/32900/001	Expansion cabinet kit - Black			
31	667/1/32900/000	Expansion cabinet kit - Grey			
32	667/1/33072/000	Cabinet mounted cut-out connection kit			
33	667/1/33007/000	LSLS Expansion cabinet kit			
34					
35					
36	667/1/27056/001	Manual Panel Full kit			
37	667/1/27110/000	Manual Panel RS232 kit			
38					
39					
40	667/1/16260/000	Configuration Eprom (Issue 1. 0)	1		

Note 1:
 Please refer to special instruction pages for additional information on items marked with an '*'.

Works Order :
 EM Number : 4029
 Engineer : D B Oliver
 Intersection : Durham Road/Birtley Lane UTC - MOVA

Special Instructions

ST900 ELV CONTROLLER ITEMS LIST SHEET 2 (*I*L*)

ITEM	DRAWING NUMBER	DESCRIPTION	QTY	TOT	REMARKS
41					
42	667/1/32900/920	ST900 ELV cuckoo Kit - T200			
43	667/1/32900/921	ST900 ELV cuckoo Kit - T400			
44	667/1/32900/922	ST900 ELV cuckoo Kit - T800			
45	667/1/32900/923	ST900 ELV cuckoo Kit - Microsense			
46	667/1/32900/925	ST900 ELV cuckoo Kit - Peek			
47					
48					
49					
50					
51					
52	667/1/33073/000	ST900 Isolator locking kit			
53	667/2/20234/000	Screw Lock Key			
54					
55					
56	667/1/27104/000	ST800 / ST900 DFM Lens Kit			
57	667/1/21150/002	ST800 / ST900 Gas Plinth			
58	667/2/27096/000	ST800 / ST900 Mounting Stool			
59					
60					
61					
62	667/1/26271/000	Telephone Kit (Lightning protection)			
63	667/1/27118/000	Surge Arrester (Lightning protection)			
64					
65					
66					
67	667/1/32900/120	ST900 ELV Cabinet Export 20A 1 LSLS - Grey			
68	667/1/32900/140	ST900 ELV Cabinet Export 40A 1 LSLS - Grey			
69					
70					
71					
72					
73	667/1/32900/900	ST900 ELV export rack Kit			
74	667/1/32945/000	ST900 ELV additional LSLS rack wiring kit			
75					
76	667/1/27007/000	IRM Facility			
77					
78					
79					
80					

Works Order :
EM Number : 4029
Engineer : D B Oliver
Intersection : Durham Road/Birtley Lane UTC - MOVA

Special Instructions

Works Order :
EM Number : 4029
Engineer : D B Oliver
Intersection : Durham Road/Birtley Lane UTC - MOVA

Call Cancel

Call Cancel

Unit No.	Input Name	Call Delay	Cancel Delay	Phase Demanded (Unlatched Demand)
0	CC14	3	3	C
1	AIN1	10	1	
2	BIN6	10	1	
3	DIN9	10	1	
4	AXSINK4	6	1	
5		0	0	
6		0	0	
7		0	0	

Works Order :
 EM Number : 4029
 Engineer : D B Oliver
 Intersection : Durham Road/Birtley Lane UTC - MOVA

Inputs and Outputs

Inputs and Outputs

<input type="checkbox"/> Enable Signal Required Check boxes <input type="checkbox"/> Manual Allocation	<div style="border: 1px solid black; padding: 5px;"> Port Number & Type Port: <input style="width: 50px;" type="text" value="0"/> </div> <div style="margin-top: 5px;"> <input type="radio"/> Inputs <input type="radio"/> Outputs <input checked="" type="radio"/> Inputs & Outputs </div>	<div style="border: 1px solid black; padding: 5px;"> Card Type & Address Intelligent Backplane 16/0 Card Address: 1 </div>
--	--	--

DET No	Bit No	Type I or O	Name	Req'd	BP	Inv	U/D	Misc	DFM	DFM Group	Ext time	Phs	UTC	Used By					Term Block	Terminal No			
													SDE	Pri	HC	CC	IG	UD	LRT				
<input type="radio"/>	0	0	I	AIN1	<input checked="" type="checkbox"/>	<input checked="" type="checkbox"/>	<input type="checkbox"/>	<input type="checkbox"/>	<input type="checkbox"/>	Y	0	0.0	<input checked="" type="checkbox"/>	<input type="checkbox"/>	<input type="checkbox"/>	<input type="checkbox"/>	<input type="checkbox"/>	<input checked="" type="checkbox"/>	<input type="checkbox"/>	<input type="checkbox"/>	<input type="checkbox"/>	2LT1	A1
<input type="radio"/>	1	1	I	AX2	<input checked="" type="checkbox"/>	<input checked="" type="checkbox"/>	<input type="checkbox"/>	<input type="checkbox"/>	<input type="checkbox"/>	Y	0	4.0	<input checked="" type="checkbox"/>	<input type="checkbox"/>	<input type="checkbox"/>	<input type="checkbox"/>	<input type="checkbox"/>	<input type="checkbox"/>	<input type="checkbox"/>	<input type="checkbox"/>	<input type="checkbox"/>	2LT1	A2
<input type="radio"/>	2	2	I	ASL3	<input checked="" type="checkbox"/>	<input checked="" type="checkbox"/>	<input type="checkbox"/>	<input type="checkbox"/>	<input type="checkbox"/>	A	0	0.0	<input checked="" type="checkbox"/>	<input type="checkbox"/>	<input type="checkbox"/>	<input type="checkbox"/>	<input type="checkbox"/>	<input type="checkbox"/>	<input type="checkbox"/>	<input type="checkbox"/>	<input type="checkbox"/>	2LT1	A3
<input type="radio"/>	3	3	I	AXSINK4	<input checked="" type="checkbox"/>	<input checked="" type="checkbox"/>	<input type="checkbox"/>	<input type="checkbox"/>	<input type="checkbox"/>	Y	0	0.0	<input checked="" type="checkbox"/>	<input type="checkbox"/>	<input type="checkbox"/>	<input type="checkbox"/>	<input type="checkbox"/>	<input checked="" type="checkbox"/>	<input type="checkbox"/>	<input type="checkbox"/>	<input type="checkbox"/>	2LT1	A4
<input type="radio"/>	4	4	I	COU5	<input checked="" type="checkbox"/>	<input checked="" type="checkbox"/>	<input type="checkbox"/>	<input type="checkbox"/>	<input type="checkbox"/>	Y	0	0.0	<input checked="" type="checkbox"/>	<input type="checkbox"/>	<input type="checkbox"/>	<input type="checkbox"/>	<input type="checkbox"/>	<input type="checkbox"/>	<input type="checkbox"/>	<input type="checkbox"/>	<input type="checkbox"/>	2LT1	B1
<input type="radio"/>	5	5	I	BIN6	<input checked="" type="checkbox"/>	<input checked="" type="checkbox"/>	<input type="checkbox"/>	<input type="checkbox"/>	<input type="checkbox"/>	Y	0	0.0	<input checked="" type="checkbox"/>	<input type="checkbox"/>	<input type="checkbox"/>	<input type="checkbox"/>	<input type="checkbox"/>	<input checked="" type="checkbox"/>	<input type="checkbox"/>	<input type="checkbox"/>	<input type="checkbox"/>	2LT1	B2
<input type="radio"/>	6	6	I	BX7	<input checked="" type="checkbox"/>	<input checked="" type="checkbox"/>	<input type="checkbox"/>	<input type="checkbox"/>	<input type="checkbox"/>	Y	0	4.0	<input checked="" type="checkbox"/>	<input type="checkbox"/>	<input type="checkbox"/>	<input type="checkbox"/>	<input type="checkbox"/>	<input type="checkbox"/>	<input type="checkbox"/>	<input type="checkbox"/>	<input type="checkbox"/>	2LT1	B3
<input type="radio"/>	7	7	I	BSL8	<input checked="" type="checkbox"/>	<input checked="" type="checkbox"/>	<input type="checkbox"/>	<input type="checkbox"/>	<input type="checkbox"/>	A	0	0.0	<input checked="" type="checkbox"/>	<input type="checkbox"/>	<input type="checkbox"/>	<input type="checkbox"/>	<input type="checkbox"/>	<input type="checkbox"/>	<input type="checkbox"/>	<input type="checkbox"/>	<input type="checkbox"/>	2LT1	B4

Add	Delete	Move	Clear Used By	Move to/from backplane
Manual Map Optimisation				

Works Order :
 EM Number : 4029
 Engineer : D B Oliver
 Intersection : Durham Road/Birtley Lane UTC - MOVA

Inputs and Outputs

Inputs and Outputs

<input type="checkbox"/> Enable Signal Required Check boxes <input type="checkbox"/> Manual Allocation	<div style="border: 1px solid black; padding: 5px;"> Port Number & Type Port: <input style="width: 50px;" type="text" value="1"/> </div> <div style="margin-top: 5px;"> <input type="radio"/> Inputs <input type="radio"/> Outputs <input checked="" type="radio"/> Inputs & Outputs </div>	<div style="border: 1px solid black; padding: 5px;"> Card Type & Address Intelligent Backplane 16/0 Card Address: 1 </div>
--	--	--

DET No	Bit No	Type I or O	Name	Req'd	BP	Inv	U/D	Misc	DFM	DFM Group	Ext time	Phs	UTC	Used By					Term Block	Terminal No			
													SDE	Pri	HC	CC	IG	UD	LRT				
<input type="radio"/>	8	0	I	DIN9	<input checked="" type="checkbox"/>	<input checked="" type="checkbox"/>	<input type="checkbox"/>	<input type="checkbox"/>	<input type="checkbox"/>	Y	0	0.0	<input checked="" type="checkbox"/>	<input type="checkbox"/>	<input type="checkbox"/>	<input type="checkbox"/>	<input type="checkbox"/>	<input checked="" type="checkbox"/>	<input type="checkbox"/>	<input type="checkbox"/>	<input type="checkbox"/>	2LT1	C1
<input type="radio"/>	9	1	I	DX10	<input checked="" type="checkbox"/>	<input checked="" type="checkbox"/>	<input type="checkbox"/>	<input type="checkbox"/>	<input type="checkbox"/>	Y	0	3.0	<input checked="" type="checkbox"/>	<input type="checkbox"/>	<input type="checkbox"/>	<input type="checkbox"/>	<input type="checkbox"/>	<input type="checkbox"/>	<input type="checkbox"/>	<input type="checkbox"/>	<input type="checkbox"/>	2LT1	C2
<input type="radio"/>	10	2	I	DSL11	<input checked="" type="checkbox"/>	<input checked="" type="checkbox"/>	<input type="checkbox"/>	<input type="checkbox"/>	<input type="checkbox"/>	A	0	0.0	<input checked="" type="checkbox"/>	<input type="checkbox"/>	<input type="checkbox"/>	<input type="checkbox"/>	<input type="checkbox"/>	<input type="checkbox"/>	<input type="checkbox"/>	<input type="checkbox"/>	<input type="checkbox"/>	2LT1	C3
<input type="radio"/>	11	3	I	DX12	<input checked="" type="checkbox"/>	<input checked="" type="checkbox"/>	<input type="checkbox"/>	<input type="checkbox"/>	<input type="checkbox"/>	Y	0	3.0	<input checked="" type="checkbox"/>	<input type="checkbox"/>	<input type="checkbox"/>	<input type="checkbox"/>	<input type="checkbox"/>	<input type="checkbox"/>	<input type="checkbox"/>	<input type="checkbox"/>	<input type="checkbox"/>	2LT1	C4
<input type="radio"/>	12	4	I	DSL13	<input checked="" type="checkbox"/>	<input checked="" type="checkbox"/>	<input type="checkbox"/>	<input type="checkbox"/>	<input type="checkbox"/>	A	0	0.0	<input checked="" type="checkbox"/>	<input type="checkbox"/>	<input type="checkbox"/>	<input type="checkbox"/>	<input type="checkbox"/>	<input type="checkbox"/>	<input type="checkbox"/>	<input type="checkbox"/>	<input type="checkbox"/>	2LT1	D1
<input type="radio"/>	13	5	I	CC14	<input checked="" type="checkbox"/>	<input checked="" type="checkbox"/>	<input type="checkbox"/>	<input type="checkbox"/>	<input type="checkbox"/>	Y	0	2.0	<input checked="" type="checkbox"/>	<input type="checkbox"/>	<input type="checkbox"/>	<input type="checkbox"/>	<input type="checkbox"/>	<input checked="" type="checkbox"/>	<input type="checkbox"/>	<input type="checkbox"/>	<input type="checkbox"/>	2LT1	D2
<input type="radio"/>	14	6	I		<input type="checkbox"/>	<input type="checkbox"/>	<input type="checkbox"/>	<input type="checkbox"/>	<input type="checkbox"/>				<input type="checkbox"/>	<input type="checkbox"/>	<input type="checkbox"/>	<input type="checkbox"/>	<input type="checkbox"/>	<input type="checkbox"/>	<input type="checkbox"/>	<input type="checkbox"/>	<input type="checkbox"/>	2LT1	D3
<input type="radio"/>	15	7	I		<input type="checkbox"/>	<input type="checkbox"/>	<input type="checkbox"/>	<input type="checkbox"/>	<input type="checkbox"/>				<input type="checkbox"/>	<input type="checkbox"/>	<input type="checkbox"/>	<input type="checkbox"/>	<input type="checkbox"/>	<input type="checkbox"/>	<input type="checkbox"/>	<input type="checkbox"/>	<input type="checkbox"/>	2LT1	D4

Add	Delete	Move	Clear Used By	Move to/from backplane
Manual Map Optimisation				

Works Order :
 EM Number : 4029
 Engineer : D B Oliver
 Intersection : Durham Road/Birtley Lane UTC - MOVA

Inputs and Outputs

Inputs and Outputs

<input type="checkbox"/> Enable Signal Required Check boxes <input type="checkbox"/> Manual Allocation	<p style="text-align: center;">Port Number & Type</p> Port: <input style="width: 50px;" type="text" value="2"/> <div style="display: flex; justify-content: space-around; margin-top: 5px;"> <input type="radio"/> Inputs <input type="radio"/> Outputs <input checked="" type="radio"/> Inputs & Outputs </div>	<p style="text-align: center;">Card Type & Address</p> Serial IO 24/16 Card Address: 2
--	--	---

	DET No	Bit No	Type I or O	Name	Req'd	BP	Inv	U/D	Misc	DFM	DFM Group	Ext time	Used By								Term Block	Line No			
													Phs	UTC	SDE	Pri	HC	CC	IG	UD			LRT		
<input type="radio"/>	16	0	I	1PBE	<input checked="" type="checkbox"/>	<input type="checkbox"/>	<input type="checkbox"/>	<input type="checkbox"/>	<input type="checkbox"/>	N		0.0	<input checked="" type="checkbox"/>	<input type="checkbox"/>	<input type="checkbox"/>	<input type="checkbox"/>	<input type="checkbox"/>	<input type="checkbox"/>	<input type="checkbox"/>	<input type="checkbox"/>	<input type="checkbox"/>	<input type="checkbox"/>	11/O1	I-0	
<input type="radio"/>	17	1	I	1PKE	<input checked="" type="checkbox"/>	<input type="checkbox"/>	<input checked="" type="checkbox"/>	<input type="checkbox"/>	<input type="checkbox"/>	N		0.0	<input checked="" type="checkbox"/>	<input type="checkbox"/>	<input type="checkbox"/>	<input type="checkbox"/>	<input type="checkbox"/>	<input type="checkbox"/>	<input type="checkbox"/>	<input type="checkbox"/>	<input type="checkbox"/>	<input type="checkbox"/>	<input type="checkbox"/>	11/O1	I-1
<input type="radio"/>	18	2	I	2PBE	<input checked="" type="checkbox"/>	<input type="checkbox"/>	<input type="checkbox"/>	<input type="checkbox"/>	<input type="checkbox"/>	N		0.0	<input checked="" type="checkbox"/>	<input type="checkbox"/>	<input type="checkbox"/>	<input type="checkbox"/>	<input type="checkbox"/>	<input type="checkbox"/>	<input type="checkbox"/>	<input type="checkbox"/>	<input type="checkbox"/>	<input type="checkbox"/>	11/O1	I-2	
<input type="radio"/>	19	3	I	2PKE	<input checked="" type="checkbox"/>	<input type="checkbox"/>	<input checked="" type="checkbox"/>	<input type="checkbox"/>	<input type="checkbox"/>	N		0.0	<input checked="" type="checkbox"/>	<input type="checkbox"/>	<input type="checkbox"/>	<input type="checkbox"/>	<input type="checkbox"/>	<input type="checkbox"/>	<input type="checkbox"/>	<input type="checkbox"/>	<input type="checkbox"/>	<input type="checkbox"/>	11/O1	I-3	
<input type="radio"/>	20	4	I	4PBE	<input checked="" type="checkbox"/>	<input type="checkbox"/>	<input type="checkbox"/>	<input type="checkbox"/>	<input type="checkbox"/>	N		0.0	<input checked="" type="checkbox"/>	<input type="checkbox"/>	<input type="checkbox"/>	<input type="checkbox"/>	<input type="checkbox"/>	<input type="checkbox"/>	<input type="checkbox"/>	<input type="checkbox"/>	<input type="checkbox"/>	<input type="checkbox"/>	11/O1	I-4	
<input type="radio"/>	21	5	I	4PKE	<input checked="" type="checkbox"/>	<input type="checkbox"/>	<input checked="" type="checkbox"/>	<input type="checkbox"/>	<input type="checkbox"/>	N		0.0	<input checked="" type="checkbox"/>	<input type="checkbox"/>	<input type="checkbox"/>	<input type="checkbox"/>	<input type="checkbox"/>	<input type="checkbox"/>	<input type="checkbox"/>	<input type="checkbox"/>	<input type="checkbox"/>	<input type="checkbox"/>	11/O1	I-5	
<input type="radio"/>	22	6	I	5PBE	<input checked="" type="checkbox"/>	<input type="checkbox"/>	<input type="checkbox"/>	<input type="checkbox"/>	<input type="checkbox"/>	N		0.0	<input checked="" type="checkbox"/>	<input type="checkbox"/>	<input type="checkbox"/>	<input type="checkbox"/>	<input type="checkbox"/>	<input type="checkbox"/>	<input type="checkbox"/>	<input type="checkbox"/>	<input type="checkbox"/>	<input type="checkbox"/>	11/O1	I-6	
<input type="radio"/>	23	7	I	5PKE	<input checked="" type="checkbox"/>	<input type="checkbox"/>	<input checked="" type="checkbox"/>	<input type="checkbox"/>	<input type="checkbox"/>	N		0.0	<input checked="" type="checkbox"/>	<input type="checkbox"/>	<input type="checkbox"/>	<input type="checkbox"/>	<input type="checkbox"/>	<input type="checkbox"/>	<input type="checkbox"/>	<input type="checkbox"/>	<input type="checkbox"/>	<input type="checkbox"/>	11/O1	I-7	

Add	Delete	Move	Clear Used By	Move to/from backplane
Manual Map Optimisation				

Works Order :
 EM Number : 4029
 Engineer : D B Oliver
 Intersection : Durham Road/Birtley Lane UTC - MOVA

Inputs and Outputs

Inputs and Outputs

<input type="checkbox"/> Enable Signal Required Check boxes <input type="checkbox"/> Manual Allocation	<p style="text-align: center;">Port Number & Type</p> Port: <input style="width: 50px;" type="text" value="3"/> <div style="display: flex; justify-content: space-around; margin-top: 5px;"> <input type="radio"/> Inputs <input type="radio"/> Outputs <input checked="" type="radio"/> Inputs & Outputs </div>	<p style="text-align: center;">Card Type & Address</p> Serial IO 24/16 Card Address: 2
--	--	---

	DET No	Bit No	Type I or O	Name	Req'd	BP	Inv	U/D	Misc	DFM	DFM Group	Ext time	Used By								Term Block	Line No
													Phs	UTC	SDE	Pri	HC	CC	IG	UD		
<input type="radio"/>	24	0	I	7PBE	<input checked="" type="checkbox"/>	<input type="checkbox"/>	<input type="checkbox"/>	<input type="checkbox"/>	<input type="checkbox"/>	N		0.0	<input type="checkbox"/>	<input type="checkbox"/>	<input type="checkbox"/>	<input type="checkbox"/>	<input type="checkbox"/>	<input type="checkbox"/>	<input type="checkbox"/>	<input type="checkbox"/>	11/O1	I-8
<input type="radio"/>	25	1	I	7PKE	<input checked="" type="checkbox"/>	<input type="checkbox"/>	<input checked="" type="checkbox"/>	<input type="checkbox"/>	<input type="checkbox"/>	N		0.0	<input type="checkbox"/>	<input type="checkbox"/>	<input type="checkbox"/>	<input type="checkbox"/>	<input type="checkbox"/>	<input type="checkbox"/>	<input type="checkbox"/>	<input type="checkbox"/>	11/O1	I-9
<input type="radio"/>	26	2	I	8PBE	<input checked="" type="checkbox"/>	<input type="checkbox"/>	<input type="checkbox"/>	<input type="checkbox"/>	<input type="checkbox"/>	N		0.0	<input type="checkbox"/>	<input type="checkbox"/>	<input type="checkbox"/>	<input type="checkbox"/>	<input type="checkbox"/>	<input type="checkbox"/>	<input type="checkbox"/>	<input type="checkbox"/>	11/O1	I-10
<input type="radio"/>	27	3	I	8PKE	<input checked="" type="checkbox"/>	<input type="checkbox"/>	<input checked="" type="checkbox"/>	<input type="checkbox"/>	<input type="checkbox"/>	N		0.0	<input type="checkbox"/>	<input type="checkbox"/>	<input type="checkbox"/>	<input type="checkbox"/>	<input type="checkbox"/>	<input type="checkbox"/>	<input type="checkbox"/>	<input type="checkbox"/>	11/O1	I-11
<input type="radio"/>	28	4	I		<input type="checkbox"/>	<input type="checkbox"/>	<input type="checkbox"/>	<input type="checkbox"/>	<input type="checkbox"/>				<input type="checkbox"/>	<input type="checkbox"/>	<input type="checkbox"/>	<input type="checkbox"/>	<input type="checkbox"/>	<input type="checkbox"/>	<input type="checkbox"/>	<input type="checkbox"/>	11/O1	I-12
<input type="radio"/>	29	5	I		<input type="checkbox"/>	<input type="checkbox"/>	<input type="checkbox"/>	<input type="checkbox"/>	<input type="checkbox"/>				<input type="checkbox"/>	<input type="checkbox"/>	<input type="checkbox"/>	<input type="checkbox"/>	<input type="checkbox"/>	<input type="checkbox"/>	<input type="checkbox"/>	<input type="checkbox"/>	11/O1	I-13
<input type="radio"/>	30	6	I		<input type="checkbox"/>	<input type="checkbox"/>	<input type="checkbox"/>	<input type="checkbox"/>	<input type="checkbox"/>				<input type="checkbox"/>	<input type="checkbox"/>	<input type="checkbox"/>	<input type="checkbox"/>	<input type="checkbox"/>	<input type="checkbox"/>	<input type="checkbox"/>	<input type="checkbox"/>	11/O1	I-14
<input type="radio"/>	31	7	I		<input type="checkbox"/>	<input type="checkbox"/>	<input type="checkbox"/>	<input type="checkbox"/>	<input type="checkbox"/>				<input type="checkbox"/>	<input type="checkbox"/>	<input type="checkbox"/>	<input type="checkbox"/>	<input type="checkbox"/>	<input type="checkbox"/>	<input type="checkbox"/>	<input type="checkbox"/>	11/O1	I-15

Add	Delete	Move	Clear Used By	Move to/from backplane
Manual Map Optimisation				

Works Order :
 EM Number : 4029
 Engineer : D B Oliver
 Intersection : Durham Road/Birtley Lane UTC - MOVA

Inputs and Outputs

Inputs and Outputs

<input type="checkbox"/> Enable Signal Required Check boxes <input type="checkbox"/> Manual Allocation	<p style="text-align: center;">Port Number & Type</p> Port: <input style="width: 50px;" type="text" value="4"/> <div style="display: flex; justify-content: space-around; margin-top: 5px;"> <input type="radio"/> Inputs <input type="radio"/> Outputs <input checked="" type="radio"/> Inputs & Outputs </div>	<p style="text-align: center;">Card Type & Address</p> Serial IO 24/16 Card Address: 2
--	--	---

	DET No	Bit No	Type I or O	Name	Req'd	BP	Inv	U/D	Misc	DFM	DFM Group	Ext time	Used By								Term Block	Line No			
													Phs	UTC	SDE	Pri	HC	CC	IG	UD			LRT		
<input type="radio"/>	32	0	I	1PCE	<input checked="" type="checkbox"/>	<input type="checkbox"/>	<input checked="" type="checkbox"/>	<input type="checkbox"/>	<input type="checkbox"/>	N		0.6	<input checked="" type="checkbox"/>	<input type="checkbox"/>	<input type="checkbox"/>	<input type="checkbox"/>	<input type="checkbox"/>	<input type="checkbox"/>	<input type="checkbox"/>	<input type="checkbox"/>	<input type="checkbox"/>	<input type="checkbox"/>	<input type="checkbox"/>	11/O1	I-16
<input type="radio"/>	33	1	I	2PCE	<input checked="" type="checkbox"/>	<input type="checkbox"/>	<input checked="" type="checkbox"/>	<input type="checkbox"/>	<input type="checkbox"/>	N		0.6	<input checked="" type="checkbox"/>	<input type="checkbox"/>	<input type="checkbox"/>	<input type="checkbox"/>	<input type="checkbox"/>	<input type="checkbox"/>	<input type="checkbox"/>	<input type="checkbox"/>	<input type="checkbox"/>	<input type="checkbox"/>	<input type="checkbox"/>	11/O1	I-17
<input type="radio"/>	34	2	I	4PCE	<input checked="" type="checkbox"/>	<input type="checkbox"/>	<input checked="" type="checkbox"/>	<input type="checkbox"/>	<input type="checkbox"/>	N		0.6	<input checked="" type="checkbox"/>	<input type="checkbox"/>	<input type="checkbox"/>	<input type="checkbox"/>	<input type="checkbox"/>	<input type="checkbox"/>	<input type="checkbox"/>	<input type="checkbox"/>	<input type="checkbox"/>	<input type="checkbox"/>	<input type="checkbox"/>	11/O1	I-18
<input type="radio"/>	35	3	I	5PCE	<input checked="" type="checkbox"/>	<input type="checkbox"/>	<input checked="" type="checkbox"/>	<input type="checkbox"/>	<input type="checkbox"/>	N		0.6	<input checked="" type="checkbox"/>	<input type="checkbox"/>	<input type="checkbox"/>	<input type="checkbox"/>	<input type="checkbox"/>	<input type="checkbox"/>	<input type="checkbox"/>	<input type="checkbox"/>	<input type="checkbox"/>	<input type="checkbox"/>	<input type="checkbox"/>	11/O1	I-19
<input type="radio"/>	36	4	I	7PCE	<input checked="" type="checkbox"/>	<input type="checkbox"/>	<input checked="" type="checkbox"/>	<input type="checkbox"/>	<input type="checkbox"/>	N		0.6	<input type="checkbox"/>	<input type="checkbox"/>	<input type="checkbox"/>	<input type="checkbox"/>	<input type="checkbox"/>	<input type="checkbox"/>	<input type="checkbox"/>	<input type="checkbox"/>	<input type="checkbox"/>	<input type="checkbox"/>	<input type="checkbox"/>	11/O1	I-20
<input type="radio"/>	37	5	I	8PCE	<input checked="" type="checkbox"/>	<input type="checkbox"/>	<input checked="" type="checkbox"/>	<input type="checkbox"/>	<input type="checkbox"/>	N		0.6	<input type="checkbox"/>	<input type="checkbox"/>	<input type="checkbox"/>	<input type="checkbox"/>	<input type="checkbox"/>	<input type="checkbox"/>	<input type="checkbox"/>	<input type="checkbox"/>	<input type="checkbox"/>	<input type="checkbox"/>	<input type="checkbox"/>	11/O1	I-21
<input type="radio"/>	38	6	I		<input type="checkbox"/>	<input type="checkbox"/>	<input type="checkbox"/>	<input type="checkbox"/>	<input type="checkbox"/>				<input type="checkbox"/>	<input type="checkbox"/>	<input type="checkbox"/>	<input type="checkbox"/>	<input type="checkbox"/>	<input type="checkbox"/>	<input type="checkbox"/>	<input type="checkbox"/>	<input type="checkbox"/>	<input type="checkbox"/>	<input type="checkbox"/>	11/O1	I-22
<input type="radio"/>	39	7	I		<input type="checkbox"/>	<input type="checkbox"/>	<input type="checkbox"/>	<input type="checkbox"/>	<input type="checkbox"/>				<input type="checkbox"/>	<input type="checkbox"/>	<input type="checkbox"/>	<input type="checkbox"/>	<input type="checkbox"/>	<input type="checkbox"/>	<input type="checkbox"/>	<input type="checkbox"/>	<input type="checkbox"/>	<input type="checkbox"/>	<input type="checkbox"/>	11/O1	I-23

Add	Delete	Move	Clear Used By	Move to/from backplane
Manual Map Optimisation				

Works Order :
 EM Number : 4029
 Engineer : D B Oliver
 Intersection : Durham Road/Birtley Lane UTC - MOVA

Inputs and Outputs

Inputs and Outputs

- Enable Signal Required
Check boxes
- Manual Allocation

Port Number & Type

Port:

Inputs Outputs
 Inputs & Outputs

Card Type & Address

Serial IO 24/16
 Card Address: 2

	DET No	Bit No	Type I or O	Name	Req'd	BP	Inv	U/D	Misc	DFM	DFM Group	Ext time	Used By								Term Block	Line No	
													Phs	UTC	SDE	Pri	HC	CC	IG	UD			LRT
<input type="radio"/>	40	0	O	CLCKSYNC	<input checked="" type="checkbox"/>	<input type="checkbox"/>	<input type="checkbox"/>	<input type="checkbox"/>	<input type="checkbox"/>	N		0.0	<input type="checkbox"/>	<input type="checkbox"/>	<input type="checkbox"/>	<input type="checkbox"/>	<input type="checkbox"/>	<input type="checkbox"/>	<input type="checkbox"/>	<input type="checkbox"/>	<input type="checkbox"/>	1/01	O-0
<input type="radio"/>	41	1	O	TOST1	<input checked="" type="checkbox"/>	<input type="checkbox"/>	<input type="checkbox"/>	<input type="checkbox"/>	<input type="checkbox"/>	N		0.0	<input type="checkbox"/>	<input type="checkbox"/>	<input type="checkbox"/>	<input type="checkbox"/>	<input type="checkbox"/>	<input type="checkbox"/>	<input type="checkbox"/>	<input type="checkbox"/>	<input type="checkbox"/>	1/01	O-1
<input type="radio"/>	42	2	O	TOST2	<input checked="" type="checkbox"/>	<input type="checkbox"/>	<input type="checkbox"/>	<input type="checkbox"/>	<input type="checkbox"/>	N		0.0	<input type="checkbox"/>	<input type="checkbox"/>	<input type="checkbox"/>	<input type="checkbox"/>	<input type="checkbox"/>	<input type="checkbox"/>	<input type="checkbox"/>	<input type="checkbox"/>	<input type="checkbox"/>	1/01	O-2
<input type="radio"/>	43	3	O	TOST3	<input checked="" type="checkbox"/>	<input type="checkbox"/>	<input type="checkbox"/>	<input type="checkbox"/>	<input type="checkbox"/>	N		0.0	<input type="checkbox"/>	<input type="checkbox"/>	<input type="checkbox"/>	<input type="checkbox"/>	<input type="checkbox"/>	<input type="checkbox"/>	<input type="checkbox"/>	<input type="checkbox"/>	<input type="checkbox"/>	1/01	O-3
<input type="radio"/>	44	4	O	TOST4	<input checked="" type="checkbox"/>	<input type="checkbox"/>	<input type="checkbox"/>	<input type="checkbox"/>	<input type="checkbox"/>	N		0.0	<input type="checkbox"/>	<input type="checkbox"/>	<input type="checkbox"/>	<input type="checkbox"/>	<input type="checkbox"/>	<input type="checkbox"/>	<input type="checkbox"/>	<input type="checkbox"/>	<input type="checkbox"/>	1/01	O-4
<input type="radio"/>	45	5	O		<input type="checkbox"/>	<input type="checkbox"/>	<input type="checkbox"/>	<input type="checkbox"/>	<input type="checkbox"/>				<input type="checkbox"/>	<input type="checkbox"/>	<input type="checkbox"/>	<input type="checkbox"/>	<input type="checkbox"/>	<input type="checkbox"/>	<input type="checkbox"/>	<input type="checkbox"/>	<input type="checkbox"/>	1/01	O-5
<input type="radio"/>	46	6	O		<input type="checkbox"/>	<input type="checkbox"/>	<input type="checkbox"/>	<input type="checkbox"/>	<input type="checkbox"/>				<input type="checkbox"/>	<input type="checkbox"/>	<input type="checkbox"/>	<input type="checkbox"/>	<input type="checkbox"/>	<input type="checkbox"/>	<input type="checkbox"/>	<input type="checkbox"/>	<input type="checkbox"/>	1/01	O-6
<input type="radio"/>	47	7	O		<input type="checkbox"/>	<input type="checkbox"/>	<input type="checkbox"/>	<input type="checkbox"/>	<input type="checkbox"/>				<input type="checkbox"/>	<input type="checkbox"/>	<input type="checkbox"/>	<input type="checkbox"/>	<input type="checkbox"/>	<input type="checkbox"/>	<input type="checkbox"/>	<input type="checkbox"/>	<input type="checkbox"/>	1/01	O-7

Works Order :
 EM Number : 4029
 Engineer : D B Oliver
 Intersection : Durham Road/Birtley Lane UTC - MOVA

Aspect Drives (ELV Controllers)

Aspect Drives (ELV Controllers)

Card Reversed

HPU Connection

1

Aspect Drive Configuration for LSLs 1 of 1 cards (Cabinet 1)

Output	Phase	Aspect	Use	Output	Phase	Aspect	Use
32	A	Red	Phase	16	E	Green	Phase
31	A	Amber	Phase	15	E	Green	Phase
30	A	Green	Phase	14	F	Green	Phase
29	B	Red	Phase	13	N/A	N/A	N/A
28	B	Amber	Phase	12	N/A	N/A	N/A
27	B	Green	Phase	11	N/A	N/A	N/A
26	C	Green	Phase	10	N/A	N/A	N/A
25	D	Red	Phase	9	N/A	N/A	N/A
24	D	Amber	Phase	8	N/A	N/A	N/A
23	D	Green	Phase	7	N/A	N/A	N/A
22	E	Red	Phase	6	N/A	N/A	N/A
21	E	Red	Phase	5	N/A	N/A	N/A
20	E	Amber	Phase	4	N/A	N/A	N/A
19	E	Amber	Phase	3	N/A	N/A	N/A
18	E	Green	Phase	2	N/A	N/A	N/A
17	E	Green	Phase	1	N/A	N/A	N/A

Works Order :
 EM Number : 4029
 Engineer : D B Oliver
 Intersection : Durham Road/Birtley Lane UTC - MOVA

I/O - DFM Group Timings

I/O - DFM Group Timings

Input Group	State	SETA	SET B	SET C	SET D
Group 0	Active (Mins)	<input type="text" value="30"/>	<input type="text" value="30"/>	<input type="text" value="30"/>	<input type="text" value="30"/>
	InActive (Hrs)	<input type="text" value="18"/>	<input type="text" value="18"/>	<input type="text" value="18"/>	<input type="text" value="18"/>
Group 1	Active (Mins)	<input type="text" value="30"/>	<input type="text" value="30"/>	<input type="text" value="30"/>	<input type="text" value="30"/>
	InActive (Hrs)	<input type="text" value="18"/>	<input type="text" value="18"/>	<input type="text" value="18"/>	<input type="text" value="18"/>
Group 2	Active (Mins)	<input type="text" value="30"/>	<input type="text" value="30"/>	<input type="text" value="30"/>	<input type="text" value="30"/>
	InActive (Hrs)	<input type="text" value="18"/>	<input type="text" value="18"/>	<input type="text" value="18"/>	<input type="text" value="18"/>
Group 3	Active (Mins)	<input type="text" value="30"/>	<input type="text" value="30"/>	<input type="text" value="30"/>	<input type="text" value="30"/>
	InActive (Hrs)	<input type="text" value="18"/>	<input type="text" value="18"/>	<input type="text" value="18"/>	<input type="text" value="18"/>
Group 4	Active (Mins)	<input type="text" value="30"/>	<input type="text" value="30"/>	<input type="text" value="30"/>	<input type="text" value="30"/>
	InActive (Hrs)	<input type="text" value="18"/>	<input type="text" value="18"/>	<input type="text" value="18"/>	<input type="text" value="18"/>
Group 5	Active (Mins)	<input type="text" value="30"/>	<input type="text" value="30"/>	<input type="text" value="30"/>	<input type="text" value="30"/>
	InActive (Hrs)	<input type="text" value="18"/>	<input type="text" value="18"/>	<input type="text" value="18"/>	<input type="text" value="18"/>
Group 6	Active (Mins)	<input type="text" value="30"/>	<input type="text" value="30"/>	<input type="text" value="30"/>	<input type="text" value="30"/>
	InActive (Hrs)	<input type="text" value="18"/>	<input type="text" value="18"/>	<input type="text" value="18"/>	<input type="text" value="18"/>
Group 7	Active (Mins)	<input type="text" value="30"/>	<input type="text" value="30"/>	<input type="text" value="30"/>	<input type="text" value="30"/>
	InActive (Hrs)	<input type="text" value="18"/>	<input type="text" value="18"/>	<input type="text" value="18"/>	<input type="text" value="18"/>

Note - 255 or blank disables DFM monitoring of that state (active or inactive) during that timeset (A to D)

Handset Limiting Values

State	Min	Max
Active (Mins)	<input type="text" value="0"/>	<input type="text" value="254"/>
InActive (Hrs)	<input type="text" value="0"/>	<input type="text" value="254"/>

Index

- 1 General Junction Data
 - 1.1 Administration
 - 1.2 Phases, Stages and Streams
 - 1.3 Facilities/Modes Enabled and Mode Priority Levels
 - 1.4 Phases in Stages
 - 1.5 Stages in Streams
- 2 Phases
 - 2.1 Phase Type and Conditions
 - 2.2 Opposing and Conflicting Phases
 - 2.3 Timings
 - 2.3.1 Phase Minimums, Maximums, Extensions, Ped Leaving Periods
 - 2.3.2 Phase Intergreen Times
 - 2.3.3 Intergreen Handset Limits
 - 2.3.4 Phase Timing Handset Ranges
 - 2.4 VA Demand and Extend Definitions
 - 2.5 Phase Internal/Revertive Demands
 - 2.6 Pelicans, Puffins and Toucans
 - 2.6.1 Phase - On Crossing and Kerbside Detector Definitions
 - 2.6.2 Stream - Pelican/Puffin/Toucan Times
 - 2.6.3 Phase - Pelican, Puffin and Toucan Times
 - 2.6.4 IO and Link - Pelican/Puffin/Toucan Times
 - 2.6.5 Pelican, Puffin, Toucan Pushbutton/Kerbside Associations
- 3 Stage Movements
 - 3.1 Stages - Prohibited, Alternative, Ignored Moves
 - 3.2 Stage Internal Demands/Pedestrian Window Times
 - 3.3 Phase Delays
 - 3.4 Intergreen Delays (No configuration data to print)
- 4 Modes and Facilities - Detailed
 - 4.1 Fixed Time
 - 4.2 Cableless Linking
 - 4.2.1 CLF - Plan(s)
 - 4.2.2 CLF - Base Time
 - 4.2.3 CLF - Demand Dependent Moves
 - 4.3 UTC and MOVA
 - 4.3.1 UTC General Data
 - 4.3.2 UTC Control and Reply Data Format
 - 4.3.3 UTC Data Definitions
 - 4.3.3.1 UTC Phase Demand and Extend Definitions
 - 4.3.3.2 UTC Stage and Mode Data Definitions
 - 4.3.3.3 UTC Demand Dependent Forces
 - 4.3.4 MOVA Stages
 - 4.3.5 UTC and MOVA Detectors
 - 4.4 Master Time Clock
 - 4.4.1 MTC - Time Switch Parameters
 - 4.4.2 MTC - Time Switch Parameters Array
 - 4.4.3 MTC - Timetable
 - 4.4.4 Holiday Clock - Special Days
 - 4.4.5 Holiday Clock - Special Holiday Periods
 - 4.5 Integral Lamp Monitoring
 - 4.5.1 LMU - General
 - 4.5.2 Integral LMU Onboard Sensors
 - 4.5.3 Integral LMU External Sensors for Regulatory Signs
 - 4.5.4 LMU Sensor Load Types
 - 4.5.5 RLM Additional Intergreens
 - 4.5.6 RLM Phase Inhibits
 - 4.6 Hurry Call
 - 4.7 Manual
 - 4.7.1 Manual Panel
 - 4.7.2 Manual Mode - Optional Phases Appearance (No configuration data to print)
 - 4.8 Reserve State
- 5 Conditioning Data
 - 5.1 Special Conditioning
 - 5.2 Special Conditioning Timers
 - 5.3 Fault Log Flags
- 6 Special Instructions
- 7 I/O
 - 7.1 Call Cancel

- 7.2 Inputs and Outputs
- 7.3 Aspect Drives (ELV Controllers)
- 7.4 I/O - DFM Group Timings

Works Order :
EM Number : 4028
Engineer : T Shaw
Intersection : Durham Road Station lane Birtley

Administration

General Specifications

Customer Name	<input type="text" value="Gateshead MBC"/>	Customer Order No.	<input type="text"/>
Intersection/ General Description	<input type="text" value="Durham Road
Station lane
Birtley"/>	Controller/ Serial Number	<input type="text"/>
Controller	<input checked="" type="radio"/> New <input type="radio"/> Modification	S.T.S./EM Number	<input type="text" value="4028"/> Issue <input type="text" value="2"/>
Area Specifications/ Customer Drawings	<input type="text"/>	Equipment Installation by	<input type="text" value="HTS"/>
Specification Section	<input type="text"/>	Slot Cutting by	<input type="text" value="HTS"/>
Contract/Tender Ref.	<input type="text"/>	Civil Works by	<input type="text" value="HTS"/>
Quotation No.	<input type="text"/>	Customer's Engineer	<input type="text" value="R KING"/>
Works Order No.	<input type="text"/>	Telephone Number	<input type="text"/>

Signal Company Use Only

Signal Engineer	<input type="text" value="T Shaw"/>	(IF PROM Label as >) PROM Number	<input type="text" value="16260"/>	PROM Variant	<input type="text" value="0"/>
		Configuration Check Value	<input type="text" value="57 EC 86 C8"/>		

Controller Options

Hardware Firmware Type and Issue Other Options

ST950/ST900/ST750 Series Cabinet Options

Cabinet/Rack Kit Type Options UK-Std Non-UK

Cabinet/Rack Variant Cuckoo Options Gemini Unit Fitted

Mains Supply	<input type="text" value="230"/> Volts	<input type="text" value="50"/> Hz					
Peak Lamp Current	<input type="text" value="8"/> Amps	Dimming Voltage	<input type="text" value="160"/>	Answer Issue	<input type="text" value="4"/>	Date Created	<input type="text" value="07/08/12"/>
Average Lamp Power	<input type="text" value="955"/> Watts	Low Inrush Transformer	<input type="checkbox"/>	Edit Issue	<input type="text" value="8"/>		
Total Average Power	<input type="text" value="1364"/> Watts						

Power feed fuse rating: requires 30 Amp minimum for controller, 15 Amp minimum for pelican/lightly loaded controller

Phases, Stages and Streams

Phases, Stages and Streams

Add/Delete/Insert Streams:

Streams	
<input checked="" type="radio"/>	Current Number of Streams <input type="text" value="1"/>

Phases	
<input type="radio"/>	Current Total Number of Phases <input type="text" value="5"/>
<input checked="" type="radio"/>	Number of Real Phases <input type="text" value="5"/>
<input type="radio"/>	Number of Dummy Phases <input type="text" value="0"/>

Stages	
<input type="radio"/>	Current Number of stages (inc.ALL-RED stages) <input type="text" value="5"/>

Switched Signs	
<input type="radio"/>	Number of Switched Signs <input type="text" value="0"/>

Action	
<input type="button" value="AddAt"/>	<input type="button" value="DeleteAt"/>

Works Order :
 EM Number : 4028
 Engineer : T Shaw
 Intersection : Durham Road Station lane Birtley

Facilities/Modes Enabled and Mode Priority Levels

Facilities

UTC

Serial/Internal UTMC OTU
 Free-standing OTU
 Serial MOVA

Master Time Clock
 Holiday Clock
 FT To Current MAX
 Linked Fixed Time

Lamp Monitoring
 RED Lamp Monitoring
 Pelican/Puffin/Toucan
 Standalone Manual

ExtendAll Red
 Speed Measurement
 Ripple Change

Non-UK
 Fail to Part Time
 Fail To Hardware Flashing
 Download To Level 3

9 Starting Intergreen

Mode Priority

	1	2	3	4	5	6	7	8	9	10	11	12	13
<input type="checkbox"/> Part Time	<input type="radio"/>	<input type="radio"/>	<input type="radio"/>	<input type="radio"/>	<input type="radio"/>	<input type="radio"/>	<input type="radio"/>	<input type="radio"/>	<input type="radio"/>	<input type="radio"/>	<input type="radio"/>	<input type="radio"/>	<input type="radio"/>
<input type="checkbox"/> Emergency Vehicles	<input type="radio"/>	<input type="radio"/>	<input type="radio"/>	<input type="radio"/>	<input type="radio"/>	<input type="radio"/>	<input type="radio"/>	<input type="radio"/>	<input type="radio"/>	<input type="radio"/>	<input type="radio"/>	<input type="radio"/>	<input type="radio"/>
<input type="checkbox"/> Hurry Call	<input type="radio"/>	<input type="radio"/>	<input type="radio"/>	<input type="radio"/>	<input type="radio"/>	<input type="radio"/>	<input type="radio"/>	<input type="radio"/>	<input type="radio"/>	<input type="radio"/>	<input type="radio"/>	<input type="radio"/>	<input type="radio"/>
<input type="checkbox"/> LRT	<input type="radio"/>	<input type="radio"/>	<input type="radio"/>	<input type="radio"/>	<input type="radio"/>	<input type="radio"/>	<input type="radio"/>	<input type="radio"/>	<input type="radio"/>	<input type="radio"/>	<input type="radio"/>	<input type="radio"/>	<input type="radio"/>
<input type="checkbox"/> Priority Vehicle	<input type="radio"/>	<input type="radio"/>	<input type="radio"/>	<input type="radio"/>	<input type="radio"/>	<input type="radio"/>	<input type="radio"/>	<input type="radio"/>	<input type="radio"/>	<input type="radio"/>	<input type="radio"/>	<input type="radio"/>	<input type="radio"/>
<input checked="" type="checkbox"/> Manual Control	<input checked="" type="radio"/>	<input type="radio"/>	<input type="radio"/>	<input type="radio"/>	<input type="radio"/>	<input type="radio"/>	<input type="radio"/>	<input type="radio"/>	<input type="radio"/>	<input type="radio"/>	<input type="radio"/>	<input type="radio"/>	<input type="radio"/>
<input type="checkbox"/> Manual Step On	<input type="radio"/>	<input type="radio"/>	<input type="radio"/>	<input type="radio"/>	<input type="radio"/>	<input type="radio"/>	<input type="radio"/>	<input type="radio"/>	<input type="radio"/>	<input type="radio"/>	<input type="radio"/>	<input type="radio"/>	<input type="radio"/>
<input checked="" type="checkbox"/> Selected FT or VA or CLF	<input type="radio"/>	<input checked="" type="radio"/>	<input type="radio"/>	<input type="radio"/>	<input type="radio"/>	<input type="radio"/>	<input type="radio"/>	<input type="radio"/>	<input type="radio"/>	<input type="radio"/>	<input type="radio"/>	<input type="radio"/>	<input type="radio"/>
<input checked="" type="checkbox"/> UTC	<input type="radio"/>	<input type="radio"/>	<input checked="" type="radio"/>	<input type="radio"/>	<input type="radio"/>	<input type="radio"/>	<input type="radio"/>	<input type="radio"/>	<input type="radio"/>	<input type="radio"/>	<input type="radio"/>	<input type="radio"/>	<input type="radio"/>
<input type="checkbox"/> MOVA Mode	<input type="radio"/>	<input type="radio"/>	<input type="radio"/>	<input type="radio"/>	<input type="radio"/>	<input type="radio"/>	<input type="radio"/>	<input type="radio"/>	<input type="radio"/>	<input type="radio"/>	<input type="radio"/>	<input type="radio"/>	<input type="radio"/>
<input type="checkbox"/> CLF (Non-Base Time)	<input type="radio"/>	<input type="radio"/>	<input type="radio"/>	<input type="radio"/>	<input type="radio"/>	<input type="radio"/>	<input type="radio"/>	<input type="radio"/>	<input type="radio"/>	<input type="radio"/>	<input type="radio"/>	<input type="radio"/>	<input type="radio"/>
<input checked="" type="checkbox"/> CLF (Base Time)	<input type="radio"/>	<input type="radio"/>	<input type="radio"/>	<input checked="" type="radio"/>	<input type="radio"/>	<input type="radio"/>	<input type="radio"/>	<input type="radio"/>	<input type="radio"/>	<input type="radio"/>	<input type="radio"/>	<input type="radio"/>	<input type="radio"/>
<input checked="" type="checkbox"/> Vehicle Actuated	<input type="radio"/>	<input type="radio"/>	<input type="radio"/>	<input type="radio"/>	<input checked="" type="radio"/>	<input type="radio"/>	<input type="radio"/>	<input type="radio"/>	<input type="radio"/>	<input type="radio"/>	<input type="radio"/>	<input type="radio"/>	<input type="radio"/>
<input checked="" type="checkbox"/> Fixed Time	<input type="radio"/>	<input type="radio"/>	<input type="radio"/>	<input type="radio"/>	<input type="radio"/>	<input checked="" type="radio"/>	<input type="radio"/>	<input type="radio"/>	<input type="radio"/>	<input type="radio"/>	<input type="radio"/>	<input type="radio"/>	<input type="radio"/>

Configuration Complexity

Low
 Medium
 High
 Maximum

standard46059.8df

Default PROM data file

Correspondence Monitoring to inc.

Reds
 Ambers
 Switched Signs
 Ignore Reds and Ambers during Fail

Flash Rate (ms)

Off
 On

Works Order :
EM Number : 4028
Engineer : T Shaw
Intersection : Durham Road Station lane Birtley

Phases in Stages

Phases

	A	B	C	D	E
0					
1	■	■			
2		■	■		
3					■
4				■	

Works Order :
 EM Number : 4028
 Engineer : T Shaw
 Intersection : Durham Road Station lane Birtley

Stages in Streams

Stages in Streams

	0	1	2	3	4	5	6	7
Phase or Stage to revert to in absence of demands/extensions	<input type="text" value="1"/>							
Startup Stage	<input type="text" value="1"/>							
Switch Off Stage	<input type="text" value="1"/>							
Standalone Pedestrian	<input type="checkbox"/>	<input type="checkbox"/>	<input type="checkbox"/>	<input type="checkbox"/>	<input type="checkbox"/>	<input type="checkbox"/>	<input type="checkbox"/>	<input type="checkbox"/>

Note: For a Stand-Alone Stream, the reversion must be to All Red stage or Traffic stage/phase to meet the relevant standard or specification.

Stages

	0	1	2	3	4
In Stream	<input checked="" type="checkbox"/>	<input checked="" type="checkbox"/>	<input checked="" type="checkbox"/>	<input checked="" type="checkbox"/>	<input checked="" type="checkbox"/>

Works Order :
 EM Number : 4028
 Engineer : T Shaw
 Intersection : Durham Road Station lane Birtley

Phase Type and Conditions

Phase Type and Conditions

Phases A to P

Improved GA Appearance

Phase	Title	Type	App. Type	Term. Type	Assoc. Phase
A	DURHAM RD NB	0 - UK Traffic	0	0 - E	
B	DURHAM RD SB	0 - UK Traffic	0	0 - E	
C	DURHAM ED RIGHT TURN	2 - UK GreenArrow	0	2 - P	B
D	STATION RD	0 - UK Traffic	0	0 - E	
E	PEDS	1 - UK Far Side Pedestrian	0	0 - E	

1) App Types: 0=Always Appears, 1=Appears if dem'd prior to interstage, 2= If dem'd, 3= If dem'd before end of window time
 2) Term Types: 0= Term's at end of stage, 1= Term's when Assoc phase gains R.O.W, 2= Term's when Assoc phase loses R.O.W.
 3) The H/W Fail Flash fields are for information only on all but ST900ELV Controllers. For other controllers, physical switches or links (etc.) select which aspects flash and these need to be set up manually.

Works Order :
 EM Number : 4028
 Engineer : T Shaw
 Intersection : Durham Road Station lane Birtley

Opposing and Conflicting Phases

Select Stream(s) To Configure

All
 0

Initialise

Amber Conflict Monitoring

To Phase

		A	B	C	D	E
From Phase	A		o	Co	Co	Co
	B	o		o	Co	Co
	C	Co	o		Co	Co
	D	Co	Co	Co		Co
	E	Co	Co	Co	Co	

Works Order :
 EM Number : 4028
 Engineer : T Shaw
 Intersection : Durham Road Station lane Birtley

Phase Minimums, Maximums, Extensions, Ped Leaving Periods

Phase Minimums, Maximums, Extensions, Ped Leaving Periods

Phases A to P

Phase	Min Green	Min Ped Clr	Extensions	Maximums								Pre-timed
				A	B	C	D	E	F	G	H	
A	7	0	0.0	30	40	40	25	25	25	25	25	<input type="checkbox"/>
B	7	0	0.0	30	40	40	25	25	25	25	25	<input type="checkbox"/>
C	5	0	0.0	15	18	18	15	15	15	15	15	<input type="checkbox"/>
D	7	0	0.0	20	25	25	15	15	15	15	15	<input type="checkbox"/>
E	9	3	0.0	0	0	0	0	0	0	0	0	<input type="checkbox"/>
												<input type="checkbox"/>
												<input type="checkbox"/>
												<input type="checkbox"/>
												<input type="checkbox"/>
												<input type="checkbox"/>
												<input type="checkbox"/>
												<input type="checkbox"/>
												<input type="checkbox"/>
												<input type="checkbox"/>
												<input type="checkbox"/>
												<input type="checkbox"/>

Note: For Standalone Streams see Help for use of Max Sets.

Works Order :
 EM Number : 4028
 Engineer : T Shaw
 Intersection : Durham Road Station lane Birtley

Phase Intergreen Times

Select Stream(s) To Configure

All
 0

Note: On a Stand Alone Pelican/Toucan/Puffin Stream the Intergreens between Pedestrian and Traffic Phases are controlled by the timings (PBT, PIT, CMX, CDY, CRD and PAR), therefore 0 should be entered for the appropriate intergreen times in grid below.

To Phase

		A	B	C	D	E
From Phase	A			5	6	7
	B				6	7
	C	5			6	7
	D	5	5	5		7
	E	9	9	9	8	

Works Order :
EM Number : 4028
Engineer : T Shaw
Intersection : Durham Road Station lane Birtley

Intergreen Handset Limits

HIGH

To Phase

	A	B	C	D	E
A			5	5	5
B				5	5
C	5			5	5
D	5	5	5		5
E	5	5	5	5	

Phase Timing Handset Ranges

Phase Timing Handset Ranges			
Initialise Min Green Limits			
Phase	Min. Green		Phase
	Min.	Max.	
A	<input type="text" value="3"/>	<input type="text" value="255"/>	Q
B	<input type="text" value="3"/>	<input type="text" value="255"/>	R
C	<input type="text" value="3"/>	<input type="text" value="255"/>	S
D	<input type="text" value="3"/>	<input type="text" value="255"/>	T
E	<input type="text" value="6"/>	<input type="text" value="255"/>	U
F			V
G			W
H			X
I			Y
J			Z
K			A2
L			B2
M			C2
N			D2
O			E2
P			F2

<table style="width: 100%;"> <tr> <th colspan="2" style="text-align: left; padding: 5px;">Max. Green</th> </tr> <tr> <td style="width: 50%; padding: 5px;">Min. <input type="text" value="0"/></td> <td style="width: 50%; padding: 5px;">Max. <input type="text" value="255"/></td> </tr> </table>	Max. Green		Min. <input type="text" value="0"/>	Max. <input type="text" value="255"/>	<table style="width: 100%;"> <tr> <th colspan="2" style="text-align: left; padding: 5px;">Vehicle Extension</th> </tr> <tr> <td style="width: 50%; padding: 5px;">Min. <input type="text" value="0.0"/></td> <td style="width: 50%; padding: 5px;">Max. <input type="text" value="10.0"/></td> </tr> </table>	Vehicle Extension		Min. <input type="text" value="0.0"/>	Max. <input type="text" value="10.0"/>
Max. Green									
Min. <input type="text" value="0"/>	Max. <input type="text" value="255"/>								
Vehicle Extension									
Min. <input type="text" value="0.0"/>	Max. <input type="text" value="10.0"/>								
<table style="width: 100%;"> <tr> <th colspan="2" style="text-align: left; padding: 5px;">Phase Delay</th> </tr> <tr> <td style="width: 50%; padding: 5px;">Min. <input type="text" value="2"/></td> <td style="width: 50%; padding: 5px;">Max. <input type="text" value="10"/></td> </tr> </table>	Phase Delay		Min. <input type="text" value="2"/>	Max. <input type="text" value="10"/>	<table style="width: 100%;"> <tr> <th colspan="2" style="text-align: left; padding: 5px;">Starting I/G</th> </tr> <tr> <td style="width: 50%; padding: 5px;">Min. <input type="text" value="4"/></td> <td style="width: 50%; padding: 5px;">Max. <input type="text" value="12"/></td> </tr> </table>	Starting I/G		Min. <input type="text" value="4"/>	Max. <input type="text" value="12"/>
Phase Delay									
Min. <input type="text" value="2"/>	Max. <input type="text" value="10"/>								
Starting I/G									
Min. <input type="text" value="4"/>	Max. <input type="text" value="12"/>								
<table style="width: 100%;"> <tr> <th colspan="2" style="text-align: left; padding: 5px;">Min Pedestrian Clearance (PBT)</th> </tr> <tr> <td style="width: 50%; padding: 5px;">Min. <input type="text" value="0"/></td> <td style="width: 50%; padding: 5px;">Max. <input type="text" value="12"/></td> </tr> </table>	Min Pedestrian Clearance (PBT)		Min. <input type="text" value="0"/>	Max. <input type="text" value="12"/>	<table style="width: 100%;"> <tr> <th colspan="2" style="text-align: left; padding: 5px;">Traffic Phase Leaving</th> </tr> <tr> <td style="width: 50%; padding: 5px;">Min. <input type="text" value="3.0"/></td> <td style="width: 50%; padding: 5px;">Max. <input type="text" value="3.0"/></td> </tr> </table>	Traffic Phase Leaving		Min. <input type="text" value="3.0"/>	Max. <input type="text" value="3.0"/>
Min Pedestrian Clearance (PBT)									
Min. <input type="text" value="0"/>	Max. <input type="text" value="12"/>								
Traffic Phase Leaving									
Min. <input type="text" value="3.0"/>	Max. <input type="text" value="3.0"/>								
<table style="width: 100%;"> <tr> <th colspan="2" style="text-align: left; padding: 5px;">Traffic Phase Red/Amber</th> </tr> <tr> <td style="width: 50%; padding: 5px;">Min. <input type="text" value="2"/></td> <td style="width: 50%; padding: 5px;">Max. <input type="text" value="2"/></td> </tr> </table>	Traffic Phase Red/Amber		Min. <input type="text" value="2"/>	Max. <input type="text" value="2"/>					
Traffic Phase Red/Amber									
Min. <input type="text" value="2"/>	Max. <input type="text" value="2"/>								

Works Order :
 EM Number : 4028
 Engineer : T Shaw
 Intersection : Durham Road Station lane Birtley

VA Demand and Extend Definitions

VA Demand and Extend Definitions

Demands

For Unlatched demands precede the name with a #.
 Conditioning MUST be used to specify unlatched demands.

Phase				
A	ASL	MVA		
B	BSL	MVB		
C				
D	DSL	MVD		
E	PBE1	PBE2	PBE3	

Phases AtoP

Extensions

ASL	MVA		
BSL	MVB		
CX21			
DSL	MVD		

Works Order :
 EM Number : 4028
 Engineer : T Shaw
 Intersection : Durham Road Station lane Birtley

Phase Internal/Revertive Demands

Phase Internal/Revertive Demands

Start-up Vehicle Responsive Demands

A	<input checked="" type="checkbox"/>	B	<input checked="" type="checkbox"/>	C	<input checked="" type="checkbox"/>	D	<input checked="" type="checkbox"/>	E	<input checked="" type="checkbox"/>	<input type="checkbox"/>	<input type="checkbox"/>	<input type="checkbox"/>	<input type="checkbox"/>	<input type="checkbox"/>	<input type="checkbox"/>	<input type="checkbox"/>	<input type="checkbox"/>	<input type="checkbox"/>	<input type="checkbox"/>
<input type="checkbox"/>	<input type="checkbox"/>	<input type="checkbox"/>	<input type="checkbox"/>	<input type="checkbox"/>	<input type="checkbox"/>	<input type="checkbox"/>	<input type="checkbox"/>	<input type="checkbox"/>	<input type="checkbox"/>	<input type="checkbox"/>	<input type="checkbox"/>	<input type="checkbox"/>	<input type="checkbox"/>	<input type="checkbox"/>	<input type="checkbox"/>	<input type="checkbox"/>	<input type="checkbox"/>	<input type="checkbox"/>	<input type="checkbox"/>

Demands Inserted When Leaving Manual and Fixed Time Modes

A	<input checked="" type="checkbox"/>	B	<input checked="" type="checkbox"/>	C	<input checked="" type="checkbox"/>	D	<input checked="" type="checkbox"/>	E	<input checked="" type="checkbox"/>	<input type="checkbox"/>	<input type="checkbox"/>	<input type="checkbox"/>	<input type="checkbox"/>	<input type="checkbox"/>	<input type="checkbox"/>	<input type="checkbox"/>	<input type="checkbox"/>	<input type="checkbox"/>	<input type="checkbox"/>
<input type="checkbox"/>	<input type="checkbox"/>	<input type="checkbox"/>	<input type="checkbox"/>	<input type="checkbox"/>	<input type="checkbox"/>	<input type="checkbox"/>	<input type="checkbox"/>	<input type="checkbox"/>	<input type="checkbox"/>	<input type="checkbox"/>	<input type="checkbox"/>	<input type="checkbox"/>	<input type="checkbox"/>	<input type="checkbox"/>	<input type="checkbox"/>	<input type="checkbox"/>	<input type="checkbox"/>	<input type="checkbox"/>	<input type="checkbox"/>

Unlatched Demands that Start Max Timers

A	<input checked="" type="checkbox"/>	B	<input checked="" type="checkbox"/>	C	<input checked="" type="checkbox"/>	D	<input checked="" type="checkbox"/>	E	<input checked="" type="checkbox"/>	<input type="checkbox"/>	<input type="checkbox"/>	<input type="checkbox"/>	<input type="checkbox"/>	<input type="checkbox"/>	<input type="checkbox"/>	<input type="checkbox"/>	<input type="checkbox"/>	<input type="checkbox"/>	<input type="checkbox"/>
<input type="checkbox"/>	<input type="checkbox"/>	<input type="checkbox"/>	<input type="checkbox"/>	<input type="checkbox"/>	<input type="checkbox"/>	<input type="checkbox"/>	<input type="checkbox"/>	<input type="checkbox"/>	<input type="checkbox"/>	<input type="checkbox"/>	<input type="checkbox"/>	<input type="checkbox"/>	<input type="checkbox"/>	<input type="checkbox"/>	<input type="checkbox"/>	<input type="checkbox"/>	<input type="checkbox"/>	<input type="checkbox"/>	<input type="checkbox"/>

Revertive Phase Demands

A	B	C	D	E	F	G	H	I	J	K	L	M	N	O	P
<input type="text" value="A"/>	<input type="text" value="B"/>	<input type="text" value="B"/>	<input type="text" value="D"/>	<input type="text"/>											
Q	R	S	T	U	V	W	X	Y	Z	A2	B2	C2	D2	E2	F2

Works Order :
 EM Number : 4028
 Engineer : T Shaw
 Intersection : Durham Road Station lane Birtley

Stages - Prohibited, Alternative, Ignored Moves

Stages - Prohibited, Alternative, Ignored Moves

Sets	Modes	Restrictions Apply To:	No Restrictions	Modes	Restrictions Apply To:	No Restrictions
<input checked="" type="radio"/> 1	Urban Traffic Control	<input checked="" type="radio"/>	<input type="radio"/>	Manual	<input checked="" type="radio"/>	<input type="radio"/>
<input type="radio"/> 2	Cableless Linking	<input checked="" type="radio"/>	<input type="radio"/>		<input type="radio"/>	<input type="radio"/>
<input type="radio"/> 3	Vehicle Actuated	<input checked="" type="radio"/>	<input type="radio"/>		<input type="radio"/>	<input type="radio"/>
<input type="radio"/> 4		<input type="radio"/>	<input type="radio"/>		<input type="radio"/>	<input type="radio"/>
	Fixed Time	<input checked="" type="radio"/>	<input type="radio"/>		<input type="radio"/>	<input type="radio"/>
		<input type="radio"/>	<input type="radio"/>			<input type="radio"/>

To Stage

From Stage	0	1	2	3	4
0					
1					
2		4			
3			1		
4			1		

Works Order :
 EM Number : 4028
 Engineer : T Shaw
 Intersection : Durham Road Station lane Birtley

Stage Internal Demands/Pedestrian Window Times

Stage Internal Demands/Pedestrian Window Times

Start-up Vehicle Responsive Demands

0	<input type="checkbox"/>	1	<input checked="" type="checkbox"/>	2	<input checked="" type="checkbox"/>	3	<input checked="" type="checkbox"/>	4	<input checked="" type="checkbox"/>		<input type="checkbox"/>		<input type="checkbox"/>		<input type="checkbox"/>		<input type="checkbox"/>		<input type="checkbox"/>		<input type="checkbox"/>		<input type="checkbox"/>		<input type="checkbox"/>		<input type="checkbox"/>		<input type="checkbox"/>		<input type="checkbox"/>		<input type="checkbox"/>		<input type="checkbox"/>
	<input type="checkbox"/>		<input type="checkbox"/>		<input type="checkbox"/>		<input type="checkbox"/>		<input type="checkbox"/>		<input type="checkbox"/>		<input type="checkbox"/>		<input type="checkbox"/>		<input type="checkbox"/>		<input type="checkbox"/>		<input type="checkbox"/>		<input type="checkbox"/>		<input type="checkbox"/>		<input type="checkbox"/>		<input type="checkbox"/>		<input type="checkbox"/>		<input type="checkbox"/>		<input type="checkbox"/>

Demands Inserted When Leaving Manual and Fixed Time Modes

0	<input type="checkbox"/>	1	<input checked="" type="checkbox"/>	2	<input checked="" type="checkbox"/>	3	<input checked="" type="checkbox"/>	4	<input checked="" type="checkbox"/>		<input type="checkbox"/>		<input type="checkbox"/>		<input type="checkbox"/>		<input type="checkbox"/>		<input type="checkbox"/>		<input type="checkbox"/>		<input type="checkbox"/>		<input type="checkbox"/>		<input type="checkbox"/>		<input type="checkbox"/>		<input type="checkbox"/>		<input type="checkbox"/>		<input type="checkbox"/>
	<input type="checkbox"/>		<input type="checkbox"/>		<input type="checkbox"/>		<input type="checkbox"/>		<input type="checkbox"/>		<input type="checkbox"/>		<input type="checkbox"/>		<input type="checkbox"/>		<input type="checkbox"/>		<input type="checkbox"/>		<input type="checkbox"/>		<input type="checkbox"/>		<input type="checkbox"/>		<input type="checkbox"/>		<input type="checkbox"/>		<input type="checkbox"/>		<input type="checkbox"/>		<input type="checkbox"/>

Unlatched Demands that Start Maximum Timers

0	<input checked="" type="checkbox"/>	1	<input checked="" type="checkbox"/>	2	<input checked="" type="checkbox"/>	3	<input checked="" type="checkbox"/>	4	<input checked="" type="checkbox"/>		<input type="checkbox"/>		<input type="checkbox"/>		<input type="checkbox"/>		<input type="checkbox"/>		<input type="checkbox"/>		<input type="checkbox"/>		<input type="checkbox"/>		<input type="checkbox"/>		<input type="checkbox"/>		<input type="checkbox"/>		<input type="checkbox"/>		<input type="checkbox"/>		<input type="checkbox"/>
	<input type="checkbox"/>		<input type="checkbox"/>		<input type="checkbox"/>		<input type="checkbox"/>		<input type="checkbox"/>		<input type="checkbox"/>		<input type="checkbox"/>		<input type="checkbox"/>		<input type="checkbox"/>		<input type="checkbox"/>		<input type="checkbox"/>		<input type="checkbox"/>		<input type="checkbox"/>		<input type="checkbox"/>		<input type="checkbox"/>		<input type="checkbox"/>		<input type="checkbox"/>		<input type="checkbox"/>

Window Times

0	1	2	3	4	5	6	7	8	9	10	11	12	13	14	15
<input type="text" value="0"/>	<input type="text" value="0"/>	<input type="text" value="0"/>	<input type="text" value="0"/>	<input type="text" value="0"/>											
16	17	18	19	20	21	22	23	24	25	26	27	28	29	30	31

Exceptional Stages

0	<input type="checkbox"/>	1	<input type="checkbox"/>	2	<input type="checkbox"/>	3	<input type="checkbox"/>	4	<input type="checkbox"/>		<input type="checkbox"/>		<input type="checkbox"/>		<input type="checkbox"/>		<input type="checkbox"/>		<input type="checkbox"/>		<input type="checkbox"/>		<input type="checkbox"/>		<input type="checkbox"/>		<input type="checkbox"/>		<input type="checkbox"/>		<input type="checkbox"/>		<input type="checkbox"/>
	<input type="checkbox"/>		<input type="checkbox"/>		<input type="checkbox"/>		<input type="checkbox"/>		<input type="checkbox"/>		<input type="checkbox"/>		<input type="checkbox"/>		<input type="checkbox"/>		<input type="checkbox"/>		<input type="checkbox"/>		<input type="checkbox"/>		<input type="checkbox"/>		<input type="checkbox"/>		<input type="checkbox"/>		<input type="checkbox"/>		<input type="checkbox"/>		<input type="checkbox"/>

Works Order :
 EM Number : 4028
 Engineer : T Shaw
 Intersection : Durham Road Station lane Birtley

Fixed Time

Fixed Time

Stage Moves & Times (Not Fixed Time to Current Max)

Current Stage	0	1	2	3	4	5	6	7
Next Stage	<input type="text" value="1"/>	<input type="text" value="2"/>	<input type="text" value="3"/>	<input type="text" value="4"/>	<input type="text" value="1"/>			
Time	<input type="text" value="0"/>	<input type="text" value="30"/>	<input type="text" value="15"/>	<input type="text" value="10"/>	<input type="text" value="20"/>			
Current Stage	8	9	10	11	12	13	14	15
Next Stage								
Time								
Current Stage	16	17	18	19	20	21	22	23
Next Stage								
Time								
Current Stage	24	25	26	27	28	29	30	31
Next Stage								
Time								

Note:

Fixed Time mode may be used by the Reserve State, therefore, the Stage Moves and Times section should always be configured (unless Linked Fixed Time is selected instead).

Phases Demanded and Extended under Fixed Time to Current Max.

	A	B	C	D	E	F	G	H	I	J	K	L	M	N	O	P
Demand	<input checked="" type="checkbox"/>	<input checked="" type="checkbox"/>	<input type="checkbox"/>	<input checked="" type="checkbox"/>	<input type="checkbox"/>	<input type="checkbox"/>	<input type="checkbox"/>	<input type="checkbox"/>	<input type="checkbox"/>	<input type="checkbox"/>	<input type="checkbox"/>	<input type="checkbox"/>	<input type="checkbox"/>	<input type="checkbox"/>	<input type="checkbox"/>	<input type="checkbox"/>
Extend	<input checked="" type="checkbox"/>	<input checked="" type="checkbox"/>	<input type="checkbox"/>	<input checked="" type="checkbox"/>	<input type="checkbox"/>	<input type="checkbox"/>	<input type="checkbox"/>	<input type="checkbox"/>	<input type="checkbox"/>	<input type="checkbox"/>	<input type="checkbox"/>	<input type="checkbox"/>	<input type="checkbox"/>	<input type="checkbox"/>	<input type="checkbox"/>	<input type="checkbox"/>
	Q	R	S	T	U	V	W	X	Y	Z	A2	B2	C2	D2	E2	F2
Demand	<input type="checkbox"/>	<input type="checkbox"/>	<input type="checkbox"/>	<input type="checkbox"/>	<input type="checkbox"/>	<input type="checkbox"/>	<input type="checkbox"/>	<input type="checkbox"/>	<input type="checkbox"/>	<input type="checkbox"/>	<input type="checkbox"/>	<input type="checkbox"/>	<input type="checkbox"/>	<input type="checkbox"/>	<input type="checkbox"/>	<input type="checkbox"/>
Extend	<input type="checkbox"/>	<input type="checkbox"/>	<input type="checkbox"/>	<input type="checkbox"/>	<input type="checkbox"/>	<input type="checkbox"/>	<input type="checkbox"/>	<input type="checkbox"/>	<input type="checkbox"/>	<input type="checkbox"/>	<input type="checkbox"/>	<input type="checkbox"/>	<input type="checkbox"/>	<input type="checkbox"/>	<input type="checkbox"/>	<input type="checkbox"/>

Works Order :
EM Number : 4028
Engineer : T Shaw
Intersection : Durham Road Station lane Birtley

CLF - Base Time

CLF - Base Time

Controller Base Date

Controller Base Time

Plan Offset

	Minutes	Seconds		Minutes	Seconds
Plan 0	<input type="text" value="0"/>	<input type="text" value="0"/>	Plan 8	<input type="text" value="0"/>	<input type="text" value="0"/>
Plan 1	<input type="text" value="0"/>	<input type="text" value="0"/>	Plan 9	<input type="text" value="0"/>	<input type="text" value="0"/>
Plan 2	<input type="text" value="0"/>	<input type="text" value="0"/>	Plan 10	<input type="text" value="0"/>	<input type="text" value="0"/>
Plan 3	<input type="text" value="0"/>	<input type="text" value="0"/>	Plan 11	<input type="text" value="0"/>	<input type="text" value="0"/>
Plan 4	<input type="text" value="0"/>	<input type="text" value="0"/>	Plan 12	<input type="text" value="0"/>	<input type="text" value="0"/>
Plan 5	<input type="text" value="0"/>	<input type="text" value="0"/>	Plan 13	<input type="text" value="0"/>	<input type="text" value="0"/>
Plan 6	<input type="text" value="0"/>	<input type="text" value="0"/>	Plan 14	<input type="text" value="0"/>	<input type="text" value="0"/>
Plan 7	<input type="text" value="0"/>	<input type="text" value="0"/>	Plan 15	<input type="text" value="0"/>	<input type="text" value="0"/>

Handset Range Limits

	Minutes	Seconds
Min	<input type="text" value="0"/>	<input type="text" value="0"/>
Max	<input type="text" value="255"/>	<input type="text" value="59"/>

Works Order :
EM Number : 4028
Engineer : T Shaw
Intersection : Durham Road Station lane Birtley

CLF - Demand Dependent Moves

Clear Grid Data

Notes:

If no data is entered for a stage then a demand for any phases in that stage will be considered. The data specified on this screen will also change the screen CLF - Demands to Consider with Demand Dependent Stage Moves.

Phases

	A	B	C	D	E
0					
1					
2					
3					
4					

Works Order :
EM Number : 4028
Engineer : T Shaw
Intersection : Durham Road Station lane Birtley

UTC General Data

UTC General Data

Type of UTC

106

316

Integral OTU Address

Number of Control Words

Number of Reply Words

Controller to respond to TC bit.

Introduction of UTC to be disabled by Priority and LRT M

Non UTC RTC synchronisation input name

RTC Synchronisation Times

Clock Synchronise Time (UTC TS input)

Day

Time

Clock Confirm Time (UTC RT output)

Day

Time

Works Order :
 EM Number : 4028
 Engineer : T Shaw
 Intersection : Durham Road Station lane Birtley

UTC Control and Reply Data Format

UTC Control and Reply Data Format								
	Bit 1	Bit 2	Bit 3	Bit 4	Bit 5	Bit 6	Bit 7	Bit 8
Control Words								
Word 1	F1	#F2	#F3	#F4	D2	D3	D4	DX
Word 2	GO	TS						
Word 3								
Word 4								
Reply Words								
Word 1	G1	G2	G3	G4	SD2	SD3	SD4	DF
Word 2	CC	LO	LF1	LF2	LF3	MC	CF	
Word 3								
Word 4								
Word 5								
Word 6								
Word 7								
Word 8								
Word 9								
Word 10								
Word 11								
Word 12								
Word 13								
Word 14								

Works Order :
 EM Number : 4028
 Engineer : T Shaw
 Intersection : Durham Road Station lane Birtley

UTC Phase Demand and Extend Definitions

UTC Demand and Extend Definitions

Demands

For Unlatched demands, precede the name with a #.
 Conditioning MUST be used to specify unlatched demands.

Phase	Demand 1	Demand 2	Demand 3	Demand 4
A				
B				
C	D2	DX		
D	D4	DX		
E	D3			

Phases AtoP

Extensions

UTC Stage and Mode Data Definitions

UTC Stage and Mode Data Definitions

Stage	Force Bit	Green Confirm Bit	Demand Confirm Bit	Stage	Force Bit	Green Confirm Bit	Demand Confirm Bit
0				16			
1	F1	G1		17			
2	#F2	G2	SD2	18			
3	#F3	G3	SD3	19			
4	#F4	G4	SD4	20			
5				21			
6				22			
7				23			
8				24			
9				25			
10				26			
11				27			
12				28			
13				29			
14				30			
15				31			

Mode Data Definitions

Manual Mode Operative:
 G1/G2 RR

Manual Mode Selected:
 G1/G2 RR

No Lamp Power, or Lamps Off due to RLM or Part Time:
 G1/G2

Detector Fault:
 DF

Normal NOT selected on the Manual Panel:
 G1/G2 RR

RR Button Selected:
 G1/G2 RR

If UTC Reply Confirms are required for a Controller Fault (CF) OR for separate MC and RR replies, Conditioning must be used.

Works Order :
EM Number : 4028
Engineer : T Shaw
Intersection : Durham Road Station lane Birtley

UTC Demand Dependent Forces

Clear Grid Data

Notes:

If no data is entered for a stage then a demand for any phases in that stage will be considered. The data specified on this screen will also change the screen CLF - Demands to Consider with Demand Dependent Stage Moves.

Phases

	A	B	C	D	E
0					
1					
2					
3					
4					

Works Order :
 EM Number : 4028
 Engineer : T Shaw
 Intersection : Durham Road Station lane Birtley

MTC - Time Switch Parameters

MTC - Time Switch Parameters

	Type	Event		Type	Event
0	Alternate Max	MAXSETB	16	No Action	
1	Alternate Max	MAXSETC	17	No Action	
2	Alternate Max	MAXSETD	18	No Action	
3	Alternate Max	MAXSETE	19	No Action	
4	Alternate Max	MAXSETF	20	No Action	
5	Alternate Max	MAXSETG	21	No Action	
6	Alternate Max	MAXSETH	22	No Action	
7	No Action		23	No Action	
8	No Action		24	No Action	
9	No Action		25	No Action	
10	No Action		26	No Action	
11	No Action		27	No Action	
12	No Action		28	No Action	
13	No Action		29	No Action	
14	No Action		30	No Action	
15	No Action		31	No Action	

Works Order :
EM Number : 4028
Engineer : T Shaw
Intersection : Durham Road Station lane Birtley

MTC - Day Type

MTC - Day Type

No.	Mon	Tue	Wed	Thu	Fri	Sat	Sun
0	<input type="checkbox"/>	<input type="checkbox"/>	<input type="checkbox"/>	<input type="checkbox"/>	<input type="checkbox"/>	<input checked="" type="checkbox"/>	<input type="checkbox"/>
1	<input type="checkbox"/>	<input type="checkbox"/>	<input type="checkbox"/>	<input type="checkbox"/>	<input type="checkbox"/>	<input type="checkbox"/>	<input checked="" type="checkbox"/>
2	<input checked="" type="checkbox"/>	<input type="checkbox"/>	<input type="checkbox"/>	<input type="checkbox"/>	<input type="checkbox"/>	<input type="checkbox"/>	<input type="checkbox"/>
3	<input type="checkbox"/>	<input checked="" type="checkbox"/>	<input type="checkbox"/>	<input type="checkbox"/>	<input type="checkbox"/>	<input type="checkbox"/>	<input type="checkbox"/>
4	<input type="checkbox"/>	<input type="checkbox"/>	<input checked="" type="checkbox"/>	<input type="checkbox"/>	<input type="checkbox"/>	<input type="checkbox"/>	<input type="checkbox"/>
5	<input type="checkbox"/>	<input type="checkbox"/>	<input type="checkbox"/>	<input checked="" type="checkbox"/>	<input type="checkbox"/>	<input type="checkbox"/>	<input type="checkbox"/>
6	<input type="checkbox"/>	<input type="checkbox"/>	<input type="checkbox"/>	<input type="checkbox"/>	<input checked="" type="checkbox"/>	<input type="checkbox"/>	<input type="checkbox"/>
7	<input checked="" type="checkbox"/>	<input checked="" type="checkbox"/>	<input checked="" type="checkbox"/>	<input checked="" type="checkbox"/>	<input checked="" type="checkbox"/>	<input checked="" type="checkbox"/>	<input checked="" type="checkbox"/>
8	<input checked="" type="checkbox"/>	<input checked="" type="checkbox"/>	<input checked="" type="checkbox"/>	<input checked="" type="checkbox"/>	<input checked="" type="checkbox"/>	<input checked="" type="checkbox"/>	<input type="checkbox"/>
9	<input checked="" type="checkbox"/>	<input checked="" type="checkbox"/>	<input checked="" type="checkbox"/>	<input checked="" type="checkbox"/>	<input checked="" type="checkbox"/>	<input type="checkbox"/>	<input type="checkbox"/>
10	<input type="checkbox"/>	<input type="checkbox"/>	<input type="checkbox"/>	<input type="checkbox"/>	<input type="checkbox"/>	<input checked="" type="checkbox"/>	<input checked="" type="checkbox"/>
11	<input type="checkbox"/>	<input type="checkbox"/>	<input type="checkbox"/>	<input type="checkbox"/>	<input type="checkbox"/>	<input type="checkbox"/>	<input type="checkbox"/>
12	<input type="checkbox"/>	<input type="checkbox"/>	<input type="checkbox"/>	<input type="checkbox"/>	<input type="checkbox"/>	<input type="checkbox"/>	<input type="checkbox"/>
13	<input type="checkbox"/>	<input type="checkbox"/>	<input type="checkbox"/>	<input type="checkbox"/>	<input type="checkbox"/>	<input type="checkbox"/>	<input type="checkbox"/>
14	<input type="checkbox"/>	<input type="checkbox"/>	<input type="checkbox"/>	<input type="checkbox"/>	<input type="checkbox"/>	<input type="checkbox"/>	<input type="checkbox"/>
15	<input type="checkbox"/>	<input type="checkbox"/>	<input type="checkbox"/>	<input type="checkbox"/>	<input type="checkbox"/>	<input type="checkbox"/>	<input type="checkbox"/>

Works Order :
 EM Number : 4028
 Engineer : T Shaw
 Intersection : Durham Road Station lane Birtley

MTC - Timetable

MTC - Timetable

View Timetable Settings

0 - 15
 16 - 31
 32 - 47
 48 - 63

No.	Day Type	Time	Description	Function Code	Plan/Parameter
0	7	06:00:00	MAXSETA	2	0
1	8	07:30:00	MAXSETB	2	1
2	8	16:00:00	MAXSETC	2	2
3	7	23:00:00	MAXSETD	2	3
4	0			0	0
5	0			0	0
6	0			0	0
7	0			0	0
8	0			0	0
9	0			0	0
10	0			0	0
11	0			0	0
12	0			0	0
13	0			0	0
14	0			0	0
15	0			0	0

Function Codes:

- 0 = Isolate From CLF
- 1 = Introduce a CLF Plan
- 2 = Introduce a Parameter (Combination of event switches)
- 3 = Selects an Individual event switch to be set
- 4 = Selects an Individual event switch to be cleared.

Works Order :
 EM Number : 4028
 Engineer : T Shaw
 Intersection : Durham Road Station lane Birtley

Holiday Clock - Special Days

Holiday Clock - Special Days

0 - 15			16 - 31			32 - 47			48 - 63		
No.	Date	Day Type	No.	Date	Day Type	No.	Date	Day Type	No.	Date	Day Type
0	<input type="text"/>	255	16	<input type="text"/>	255	32	<input type="text"/>	255	48	<input type="text"/>	255
1	<input type="text"/>	255	17	<input type="text"/>	255	33	<input type="text"/>	255	49	<input type="text"/>	255
2	<input type="text"/>	255	18	<input type="text"/>	255	34	<input type="text"/>	255	50	<input type="text"/>	255
3	<input type="text"/>	255	19	<input type="text"/>	255	35	<input type="text"/>	255	51	<input type="text"/>	255
4	<input type="text"/>	255	20	<input type="text"/>	255	36	<input type="text"/>	255	52	<input type="text"/>	255
5	<input type="text"/>	255	21	<input type="text"/>	255	37	<input type="text"/>	255	53	<input type="text"/>	255
6	<input type="text"/>	255	22	<input type="text"/>	255	38	<input type="text"/>	255	54	<input type="text"/>	255
7	<input type="text"/>	255	23	<input type="text"/>	255	39	<input type="text"/>	255	55	<input type="text"/>	255
8	<input type="text"/>	255	24	<input type="text"/>	255	40	<input type="text"/>	255	56	<input type="text"/>	255
9	<input type="text"/>	255	25	<input type="text"/>	255	41	<input type="text"/>	255	57	<input type="text"/>	255
10	<input type="text"/>	255	26	<input type="text"/>	255	42	<input type="text"/>	255	58	<input type="text"/>	255
11	<input type="text"/>	255	27	<input type="text"/>	255	43	<input type="text"/>	255	59	<input type="text"/>	255
12	<input type="text"/>	255	28	<input type="text"/>	255	44	<input type="text"/>	255	60	<input type="text"/>	255
13	<input type="text"/>	255	29	<input type="text"/>	255	45	<input type="text"/>	255	61	<input type="text"/>	255
14	<input type="text"/>	255	30	<input type="text"/>	255	46	<input type="text"/>	255	62	<input type="text"/>	255
15	<input type="text"/>	255	31	<input type="text"/>	255	47	<input type="text"/>	255	63	<input type="text"/>	255

Note 1 - Date format = dd/mm/yyyy

Note 2 - As 0 is a valid day type, 255 has been used as the day type default.

Works Order :
EM Number : 4028
Engineer : T Shaw
Intersection : Durham Road Station lane Birtley

Holiday Clock - Special Holiday Periods

Holiday Clock - Special Holiday Periods

0 - 15		
No.	Start Date	End Date
0	<input type="text"/>	<input type="text"/>
1	<input type="text"/>	<input type="text"/>
2	<input type="text"/>	<input type="text"/>
3	<input type="text"/>	<input type="text"/>
4	<input type="text"/>	<input type="text"/>
5	<input type="text"/>	<input type="text"/>
6	<input type="text"/>	<input type="text"/>
7	<input type="text"/>	<input type="text"/>
8	<input type="text"/>	<input type="text"/>
9	<input type="text"/>	<input type="text"/>
10	<input type="text"/>	<input type="text"/>
11	<input type="text"/>	<input type="text"/>
12	<input type="text"/>	<input type="text"/>
13	<input type="text"/>	<input type="text"/>
14	<input type="text"/>	<input type="text"/>
15	<input type="text"/>	<input type="text"/>

16 - 31		
No.	Start Date	End Date
16	<input type="text"/>	<input type="text"/>
17	<input type="text"/>	<input type="text"/>
18	<input type="text"/>	<input type="text"/>
19	<input type="text"/>	<input type="text"/>
20	<input type="text"/>	<input type="text"/>
21	<input type="text"/>	<input type="text"/>
22	<input type="text"/>	<input type="text"/>
23	<input type="text"/>	<input type="text"/>
24	<input type="text"/>	<input type="text"/>
25	<input type="text"/>	<input type="text"/>
26	<input type="text"/>	<input type="text"/>
27	<input type="text"/>	<input type="text"/>
28	<input type="text"/>	<input type="text"/>
29	<input type="text"/>	<input type="text"/>
30	<input type="text"/>	<input type="text"/>
31	<input type="text"/>	<input type="text"/>

Note - Date format = dd/mm/yyyy

Works Order :
EM Number : 4028
Engineer : T Shaw
Intersection : Durham Road Station lane Birtley

LMU - General

LMU - General

Lamp Monitoring - LMU Voltage

- 200-240
 50-0-50, 100-120 230 CLS

Red Lamp Monitoring

Max Red Bulb Wattage

First Red Lamp Fault Speed

RLF2 Cancels RLM additional Intergreens

RLF2 Only Cleared by RFL = 1

RLF1 Only Cleared by RFL = 1

RLM Additional Intergreen Handset Limits

Minimum

Maximum

Streams with Phase BlackOut on RLF2

- 0

Works Order :
 EM Number : 4028
 Engineer : T Shaw
 Intersection : Durham Road Station lane Birtley

LMU - Sensors

LMU - Sensors									
Onboard Sensors					External Sensors				
Sensor\ Phase	Sensor Type	Bulb Watts	Sensor\ Phase	Sensor Type	Bulb Watts	Sensor\ Pin	Drive	Sensor Type	Bulb Watts
1\A	As Seq.	40	17\Q			33\b14		None	7
2\B	As Seq.	40	18\R			34\z16		Regulatory Sign	7
3\C	As Seq.	40	19\S			35\z14		Regulatory Sign	7
4\D	As Seq.	40	20\T			36\z12		Regulatory Sign	7
5\E	R,G,xW No Wait (Was Special 4)	40	21\U			37\b14			
6\F	As Seq.	40	22\V			38\z16			
7\G	As Seq.	40	23\W			39\z14			
8\H	As Seq.	40	24\X			40\z12			
9\I			25\Y			41\b14			
10\J			26\Z			42\z16			
11\K			27\A2			43\z14			
12\L			28\B2			44\z12			
13\M			29\C2			45\b14			
14\N			30\D2			46\z16			
15\O			31\E2			47\z14			
16\P			32\F2			48\z12			

Works Order :
EM Number : 4028
Engineer : T Shaw
Intersection : Durham Road Station lane Birtley

LMU Sensor Load Types

LMU Sensor Load Types

Screen Select

1 of 1

Sensor	Phase	Sensor Type	LED R+W	Load Type	LLF Profile
1	A	As Seq.	<input type="text" value="Auto"/>		
2	B	As Seq.	<input type="text" value="Auto"/>		
3	C	As Seq.	<input type="text" value="Auto"/>		
4	D	As Seq.	<input type="text" value="Auto"/>		
5	E	R,G,xW No Wait (Was Special 4)	<input type="text" value="Auto"/>		
6	F	As Seq.	<input type="text" value="Auto"/>		
7	G	As Seq.	<input type="text" value="Auto"/>		
8	H	As Seq.	<input type="text" value="Auto"/>		
34	N/A	Regulatory Sign	<input type="text" value="Auto"/>		
35	N/A	Regulatory Sign	<input type="text" value="Auto"/>		
36	N/A	Regulatory Sign	<input type="text" value="Auto"/>		

Works Order :
EM Number : 4028
Engineer : T Shaw
Intersection : Durham Road Station lane Birtley

RLM Additional Intergreens

Phases Delayed

	A	B	C	D	E
A	■				2
B		■			2
C			■		
D				■	2
E					■

Works Order :
EM Number : 4028
Engineer : T Shaw
Intersection : Durham Road Station lane Birtley

RLM Phase Inhibits

Phases Inhibited/Blacked-Out

	A	B	C	D	E
A					■
B					■
C					
D					■
E					

Works Order :
 EM Number : 4028
 Engineer : T Shaw
 Intersection : Durham Road Station lane Birtley

Manual Panel

Manual Panel

Stage Buttons and LEDs

Button No.	Title	Called Stage for Stream							
		0	1	2	3	4	5	6	7
0	ALLRED	0							
1	DURHAM RD	1							
2	DURHAM RD RT	2							
3	PEDS	3							
4	STATION LANE	4							
5									
6									
7									

General LEDs

	AUX1	AUX2	AUX3	AUX4 (Hurry Call)	AUX5 (Higher Priority)
Conditioned	<input checked="" type="checkbox"/>	<input checked="" type="checkbox"/>	<input checked="" type="checkbox"/>	<input checked="" type="checkbox"/>	<input checked="" type="checkbox"/>

General Buttons

	None	SW1	SW2	SW3
Momentary		<input checked="" type="checkbox"/>	<input checked="" type="checkbox"/>	<input checked="" type="checkbox"/>
Dim Override	<input type="radio"/>	<input type="radio"/>	<input type="radio"/>	<input type="radio"/>
RR	<input type="radio"/>	<input type="radio"/>	<input type="radio"/>	<input type="radio"/>

Manual Signals On

- Immediate Signals On
 As Start-Up

Manual Mode Enable

- Always
 When Handset Plugged in (Note 1)
 When 'MND' Command Entered

NOTE:
 For this to operate Special
 Conditioning is required.

Mode Select Switches Disabled

- VA Fixed Time CLF

Works Order :
 EM Number : 4028
 Engineer : T Shaw
 Intersection : Durham Road Station lane Birtley

Reserve State

Reserve State		Stream	0	1	2	3	4	5	6	7
Entry		Go to Switch Off Stage	<input type="checkbox"/>	<input type="checkbox"/>	<input type="checkbox"/>	<input type="checkbox"/>	<input type="checkbox"/>	<input type="checkbox"/>	<input type="checkbox"/>	<input type="checkbox"/>
Timeout (seconds)	Part Time on App Failure or Timeout		<input type="checkbox"/>	<input type="checkbox"/>	<input type="checkbox"/>	<input type="checkbox"/>	<input type="checkbox"/>	<input type="checkbox"/>	<input type="checkbox"/>	<input type="checkbox"/>
Limited Time		Fixed Time	<input checked="" type="radio"/>	<input checked="" type="radio"/>	<input checked="" type="radio"/>	<input checked="" type="radio"/>	<input checked="" type="radio"/>	<input checked="" type="radio"/>	<input checked="" type="radio"/>	<input checked="" type="radio"/>
Timeout (seconds)	Part Time		<input type="radio"/>	<input type="radio"/>	<input type="radio"/>	<input type="radio"/>	<input type="radio"/>	<input type="radio"/>	<input type="radio"/>	<input type="radio"/>
	Hold Stage		<input type="radio"/>	<input type="radio"/>	<input type="radio"/>	<input type="radio"/>	<input type="radio"/>	<input type="radio"/>	<input type="radio"/>	<input type="radio"/>
After Timeout		Fixed Time	<input checked="" type="radio"/>	<input checked="" type="radio"/>	<input checked="" type="radio"/>	<input checked="" type="radio"/>	<input checked="" type="radio"/>	<input checked="" type="radio"/>	<input checked="" type="radio"/>	<input checked="" type="radio"/>
	Part Time		<input type="radio"/>	<input type="radio"/>	<input type="radio"/>	<input type="radio"/>	<input type="radio"/>	<input type="radio"/>	<input type="radio"/>	<input type="radio"/>
	Hold Stage		<input type="radio"/>	<input type="radio"/>	<input type="radio"/>	<input type="radio"/>	<input type="radio"/>	<input type="radio"/>	<input type="radio"/>	<input type="radio"/>

Global Settings

Use Defaults

Timeouts

0 = Use Firmware default

Works Order :
EM Number : 4028
Engineer : T Shaw
Intersection : Durham Road Station lane Birtley

Special Conditioning

```
; CALL CANCEL CONDITIONING
;-----
;
NOT(STAGE2) := .EXOB ;CANCEL EXT FOR PHASE B IN STAGE 2
* = .EXCB
;
;-----
; HIGHER PRIORITY LED ON FOR UTC MODE
;-----
;
IFT MODE0 EQL<6> THN
TRUE=MIL17
ELS
FALSE=MIL17
END
;
;=====
; UTC REPLY BITS
;-----
;
NOT (FLF55)=LF1 ;SET UP 'LF1' (ANY LAMP FAILURE) UTC REPLY FOR ANY LAMP FAILURE
;
NOT (FLFCOM)=CF ;SET UP 'CF' (FAULT LOG ENTRY) UTC REPLY FOR FAULT LOG ENTRY
;
NOT(LMP1RED0+LMP1RED1+LMP1RED2+LMP1RED3)=LF2;SET UP 'LF2' (1ST RED FAILURE) UTC REPLY FOR 1ST RED LAMP FAILURE
;
NOT(LMP2RED0+LMP2RED1+LMP2RED2+LMP2RED3)=LF3;SET UP 'LF3' (2ND RED FAILURE) UTC REPLY FOR 2ND RED LAMP FAILURE
;
NOT(NTNORM)=MC ;SET UP 'MC' (NORMAL NOT SELECTED) UTC REPLY FOR NOT IN NORMAL
;
LMPON.NOT(FLF17)=LO ;SET UP 'LO' (SIGS OFF AT MANUAL PANEL OR NO LAMP SUPPLY) UTC REPLY FOR LAMPS OFF

MANSIGSW:=.G1 ;G1 AND G2 REPLY WITH SIGNALS OFF AT MANUAL PANEL
* = .G2
;
;=====
; GAP OUT LOGIC
;=====
;
IFT MODE0 EQL<6> THN
;
;GAP OUT FROM STAGE 1 TO STAGE 2
;-----
IFT F1.F2.GO.NOT(EXTAA) THN
FALSE=.F1
ELS
TRUE=.F1
END
;
;GAP OUT FROM STAGE 2 TO STAGE 3
;-----
IFT F2.F3.GO.NOT(EXTAC) THN
FALSE=.F2
ELS
TRUE=.F2
END
;
;GAP OUT FROM STAGE 4 TO STAGE 1
;-----
IFT F1.F4.GO.NOT(EXTAD) THN
FALSE=.F4
```

Works Order :
EM Number : 4028
Engineer : T Shaw
Intersection : Durham Road Station lane Birtley

Special Conditioning

```
ELS  
TRUE=.F4  
END  
END  
;
```

Fault Log Flags

Fault Log Flags

Fault No	Cond Flag	Act Flag	Fault No	Cond Flag	Act Flag	Fault No	Cond Flag	Act Flag	Fault No	Cond Flag	Act Flag
0	<input checked="" type="checkbox"/>	<input type="checkbox"/>	16	<input checked="" type="checkbox"/>	<input type="checkbox"/>	32	<input checked="" type="checkbox"/>	<input type="checkbox"/>	48	<input checked="" type="checkbox"/>	<input type="checkbox"/>
1	<input checked="" type="checkbox"/>	<input type="checkbox"/>	17	<input type="checkbox"/>	<input type="checkbox"/>	33	<input checked="" type="checkbox"/>	<input type="checkbox"/>	49	<input checked="" type="checkbox"/>	<input type="checkbox"/>
2	<input checked="" type="checkbox"/>	<input type="checkbox"/>	18	<input checked="" type="checkbox"/>	<input type="checkbox"/>	34	<input checked="" type="checkbox"/>	<input type="checkbox"/>	50	<input checked="" type="checkbox"/>	<input type="checkbox"/>
3	<input checked="" type="checkbox"/>	<input type="checkbox"/>	19	<input checked="" type="checkbox"/>	<input type="checkbox"/>	35	<input checked="" type="checkbox"/>	<input type="checkbox"/>	51	<input checked="" type="checkbox"/>	<input type="checkbox"/>
4	<input checked="" type="checkbox"/>	<input type="checkbox"/>	20	<input checked="" type="checkbox"/>	<input type="checkbox"/>	36	<input checked="" type="checkbox"/>	<input type="checkbox"/>	52	<input checked="" type="checkbox"/>	<input type="checkbox"/>
5	<input checked="" type="checkbox"/>	<input type="checkbox"/>	21	<input checked="" type="checkbox"/>	<input type="checkbox"/>	37	<input checked="" type="checkbox"/>	<input type="checkbox"/>	53	<input checked="" type="checkbox"/>	<input type="checkbox"/>
6	<input checked="" type="checkbox"/>	<input type="checkbox"/>	22	<input type="checkbox"/>	<input type="checkbox"/>	38	<input checked="" type="checkbox"/>	<input type="checkbox"/>	54	<input checked="" type="checkbox"/>	<input type="checkbox"/>
7	<input checked="" type="checkbox"/>	<input type="checkbox"/>	23	<input checked="" type="checkbox"/>	<input type="checkbox"/>	39	<input checked="" type="checkbox"/>	<input type="checkbox"/>	55	<input type="checkbox"/>	<input type="checkbox"/>
8	<input checked="" type="checkbox"/>	<input type="checkbox"/>	24	<input checked="" type="checkbox"/>	<input type="checkbox"/>	40	<input checked="" type="checkbox"/>	<input type="checkbox"/>	56	<input checked="" type="checkbox"/>	<input type="checkbox"/>
9	<input checked="" type="checkbox"/>	<input type="checkbox"/>	25	<input checked="" type="checkbox"/>	<input type="checkbox"/>	41	<input checked="" type="checkbox"/>	<input type="checkbox"/>	57	<input checked="" type="checkbox"/>	<input type="checkbox"/>
10	<input checked="" type="checkbox"/>	<input type="checkbox"/>	26	<input checked="" type="checkbox"/>	<input type="checkbox"/>	42	<input checked="" type="checkbox"/>	<input type="checkbox"/>	58	<input checked="" type="checkbox"/>	<input type="checkbox"/>
11	<input checked="" type="checkbox"/>	<input type="checkbox"/>	27	<input checked="" type="checkbox"/>	<input type="checkbox"/>	43	<input checked="" type="checkbox"/>	<input type="checkbox"/>	59	<input checked="" type="checkbox"/>	<input type="checkbox"/>
12	<input type="checkbox"/>	<input type="checkbox"/>	28	<input checked="" type="checkbox"/>	<input type="checkbox"/>	44	<input checked="" type="checkbox"/>	<input type="checkbox"/>	60	<input checked="" type="checkbox"/>	<input type="checkbox"/>
13	<input checked="" type="checkbox"/>	<input type="checkbox"/>	29	<input checked="" type="checkbox"/>	<input type="checkbox"/>	45	<input checked="" type="checkbox"/>	<input type="checkbox"/>	61	<input checked="" type="checkbox"/>	<input type="checkbox"/>
14	<input checked="" type="checkbox"/>	<input type="checkbox"/>	30	<input checked="" type="checkbox"/>	<input type="checkbox"/>	46	<input checked="" type="checkbox"/>	<input type="checkbox"/>	62	<input checked="" type="checkbox"/>	<input type="checkbox"/>
15	<input checked="" type="checkbox"/>	<input type="checkbox"/>	31	<input checked="" type="checkbox"/>	<input type="checkbox"/>	47	<input checked="" type="checkbox"/>	<input type="checkbox"/>	63	<input checked="" type="checkbox"/>	<input type="checkbox"/>

Note:
Cond Flag -
 If a fault occurs which sets a fault log flag that has been checked for this Cond flag option then a flag will be set that can be read in Conditioning.

Act Flag -
 If a fault occurs which sets a fault log flag that has been checked for this Act flag option then firstly the lamps

 will be switched OFF and secondly a flag will be set that can be read in conditioning, to allow any further actions required to be performed by conditioning.

 Clearance of Special Condition

Works Order :
EM Number : 4028
Engineer : T Shaw
Intersection : Durham Road Station lane Birtley

Special Instructions

4028

Card Type	Rack Posn	Addr.	Port	Type	Line	Term Posn
Intelligent Backplane 16/0	Rack	01	0	I	000 - 007	1 LT1
Intelligent Backplane 16/0	Rack	01	1	I	008 - 015	1 LT1
Serial IO 24/4	1 I/O1	02	2	I	016 - 023	1 I/O1
Serial IO 24/4	1 I/O1	02	3	I	024 - 031	1 I/O1
Serial IO 24/4	1 I/O1	02	4	I	032 - 039	1 I/O1
Serial IO 24/4	1 I/O1	02	5	O	040 - 043	1 I/O1
CPU	A					

Works Order :
 EM Number : 4028
 Engineer : T Shaw
 Intersection : Durham Road Station lane Birtley

Special Instructions

ST900 CONTROLLER ITEMS LIST SHEET 1 (*I*L*)

ITEM	DRAWING NUMBER	DESCRIPTION	QTY	TOT	REMARKS
1					
2	667/1/33900/010	ST900 Cabinet UK 1.5KVA 8ph wired 8ph - Grey			
3	667/1/33900/020	ST900 Cabinet UK 2KVA 24ph wired 32ph - Grey			
4	667/1/33900/011	ST900 Cabinet UK 1.5KVA 8ph wired 8ph - Black	1		
5	667/1/33900/021	ST900 Cabinet UK 2KVA 24ph wired 32ph - Black			
6					
7					
8	667/1/--na-/900	ST900 Rack UK 8 Phase wired 8 phase			
9	667/1/--na-/901	ST900 Rack UK 24 Phase wired 32 phase			
10					
11					
12	667/1/27072/001	Cableform 8 Phase (long)			
13	667/1/27002/000	Lamp Switch Kit 8 Phase			
14	667/1/27008/001	16 - 32 phase controller upgrade kit			
15					
16					
17	667/1/32995/002	ST900 I/O card kit (4 outputs)	1		
18	667/1/32995/001	ST900 I/O card kit (16 outputs)			
19					
20					
21	667/1/27005/000	SDE Facility Kit			
22	667/1/27004/000	Integral OTU Kit			
23	667/1/32910/000	ST900 Intelligent detector backplane kit	1		
24	667/1/20690/001	19" Detector rack			
25					
26	667/1/27084/001	Dimming Assembly (1.5KVA) (Fit Std UK)			
27	667/1/27084/003	Dimming Assembly (3.0KVA)			
28	667/1/27130/900	ST900 30A Mod Kit			
29	667/1/27084/005	Dimming Facility (Sao Paulo)			
30					
31	667/1/33009/000	ST900 300mA RCD kit			
32	667/7/25171/000	Current Monitoring Torroid			
33					
34	667/1/32900/001	Expansion cabinet kit - Black			
35	667/1/32900/000	Expansion cabinet kit - Grey			
36	667/1/33072/000	Cabinet mounted cut-out connection kit			
37	667/1/27083/000	Additional rear termination Kit			
38					
39	667/1/16260/000	Configuration Eprom (Issue 0. 3)	1		
40					

Note 1:
 Please refer to special instruction pages for additional information on items marked with an '*'.

 For CLS see items 81 onwards

Works Order :
 EM Number : 4028
 Engineer : T Shaw
 Intersection : Durham Road Station lane Birtley

Special Instructions

ST900 CONTROLLER ITEMS LIST SHEET 2 (*I*L*)

ITEM	DRAWING NUMBER	DESCRIPTION	QTY	TOT	REMARKS
41					
42	667/1/27056/001	Manual Panel Full Kit			
43	667/1/27110/000	Manual Panel RS232 kit			
44					
45					
46	667/1/--na-/910	ST900 cuckoo Kit - T200			
47	667/1/--na-/911	ST900 cuckoo Kit - T400			
48	667/1/--na-/913	ST900 cuckoo Kit - Microsense			
49	667/1/--na-/915	ST900 cuckoo Kit - Peek			
50					
51					
52	667/1/33073/000	ST900 Isolator locking kit			
53	667/2/20234/000	Screw Lock Key			
54					
55					
56	667/1/27104/000	ST800 / ST900 DFM Lens Kit			
57	667/1/21150/002	ST800 / ST900 Gas Plinth			
58	667/2/27096/000	ST800 / ST900 Mounting Stool			
59					
60					
61	667/1/33900/110	ST900 Cab Export 8ph wired 8ph - Grey			
62	667/1/33900/120	ST900 Cab Export 24ph wired 32ph - Grey			
63					
64	667/1/33900/950	ST900 Rack Export 8 Ph wired 8 ph			
65	667/1/33900/951	ST900 Rack Export 24 Ph wired 32 ph			
66	667/1/33900/960	ST900SE 11" Rack Export 8 Ph wired 8 ph			
67					
68					
69	667/1/27002/100	Lamp Switch Kit Export			
70	667/1/27223/403	4 ph Export Lamp Switch kit (No LMU)			
71	667/1/27223/003	8 ph Export Lamp Switch kit (No LMU)			
72					
73	667/1/27007/000	IRM Facility			
74					
75	667/1/26271/000	Telephone Kit (Lightning protection)			
76	667/1/27118/000	Surge Arrester (Lightning protection)			
77					
78					
79					
80					

Works Order :
 EM Number : 4028
 Engineer : T Shaw
 Intersection : Durham Road Station lane Birtley

Special Instructions

ST900 CONTROLLER ITEMS LIST SHEET 3 (*I*L*)

ITEM	DRAWING NUMBER	DESCRIPTION	QTY	TOT	REMARKS
81	667/1/33900/018	ST900 Cab UK 1.5KVA CLS 8ph wired 8ph - Grey			}
82	667/1/33900/028	ST900 Cab UK 2KVA CLS 24ph wired 32ph - Grey			}
83	667/1/33900/019	ST900 Cab UK 1.5KVA CLS 8ph wired 8ph - Black			}
84	667/1/33900/029	ST900 Cab UK 2KVA CLS 24ph wired 32ph - Black			}
85	667/1/--na-/908	ST900 Rack UK CLS 8 Phase wired 8 phase			}
86	667/1/--na-/909	ST900 Rack UK CLS 24 Phase wired 32 phase			}
87					}
88	667/1/33900/118	ST900 Cab Export CLS 8ph wired 8ph - Grey			} CLS items
89	667/1/33900/128	ST900 Cab Export CLS 24ph wired 32ph - Grey			}
90	667/1/33900/958	ST900 Rack Export CLS 8 Ph wired 8 ph			}
91	667/1/33900/959	ST900 Rack Export CLS 24 Ph wired 32 ph			}
92	667/1/33900/968	ST900SE 11" Rack Export CLS 8 Ph wired 8 ph			}
93	667/1/27002/002	Lamp Switch Kit CLS 8 Phase			}
94	667/1/27002/102	Lamp Switch Kit CLS Export			}
95					}
96					}
97					}
98					}
99					}

Works Order :
EM Number : 4028
Engineer : T Shaw
Intersection : Durham Road Station lane Birtley

Special Instructions

Works Order :
EM Number : 4028
Engineer : T Shaw
Intersection : Durham Road Station lane Birtley

Call Cancel

Call Cancel

Unit No.	Input Name	Call Delay	Cancel Delay	Phase Demanded (Unlatched Demand)
0	CX21	4	4	C
1		0	0	
2		0	0	
3		0	0	
4		0	0	
5		0	0	
6		0	0	
7		0	0	

Works Order :
 EM Number : 4028
 Engineer : T Shaw
 Intersection : Durham Road Station lane Birtley

Inputs and Outputs

Inputs and Outputs

<input type="checkbox"/> Enable Signal Required Check boxes <input type="checkbox"/> Manual Allocation	<p style="text-align: center;">Port Number & Type</p> Port: <input style="width: 50px;" type="text" value="0"/> <div style="display: flex; justify-content: space-around; margin-top: 10px;"> <input type="radio"/> Inputs <input type="radio"/> Outputs </div> <div style="display: flex; justify-content: center; margin-top: 5px;"> <input checked="" type="radio"/> Inputs & Outputs </div>	<p style="text-align: center;">Card Type & Address</p> Intelligent Backplane 16/0 Card Address: 1
--	---	--

DET No	Bit No	Type I or O	Name	Req'd	BP	Inv	U/D	Misc	DFM	DFM Group	Ext time	Phs	UTC	Used By					Term Block	Terminal No				
													SDE	Pri	HC	CC	IG	UD	LRT					
<input type="radio"/>	0	0	ASL	<input checked="" type="checkbox"/>	<input checked="" type="checkbox"/>	<input type="checkbox"/>	<input type="checkbox"/>	<input type="checkbox"/>	A	0	1.0	<input checked="" type="checkbox"/>	<input type="checkbox"/>	<input type="checkbox"/>	<input type="checkbox"/>	<input type="checkbox"/>	<input type="checkbox"/>	<input type="checkbox"/>	<input type="checkbox"/>	<input type="checkbox"/>	<input type="checkbox"/>	1LT1	A1	
<input type="radio"/>	1	1	BSL	<input checked="" type="checkbox"/>	<input checked="" type="checkbox"/>	<input type="checkbox"/>	<input type="checkbox"/>	<input type="checkbox"/>	A	0	1.0	<input checked="" type="checkbox"/>	<input type="checkbox"/>	<input type="checkbox"/>	<input type="checkbox"/>	<input type="checkbox"/>	<input type="checkbox"/>	<input type="checkbox"/>	<input type="checkbox"/>	<input type="checkbox"/>	<input type="checkbox"/>	<input type="checkbox"/>	1LT1	A2
<input type="radio"/>	2	2	DSL	<input checked="" type="checkbox"/>	<input checked="" type="checkbox"/>	<input type="checkbox"/>	<input type="checkbox"/>	<input type="checkbox"/>	A	0	1.0	<input checked="" type="checkbox"/>	<input type="checkbox"/>	<input type="checkbox"/>	<input type="checkbox"/>	<input type="checkbox"/>	<input type="checkbox"/>	<input type="checkbox"/>	<input type="checkbox"/>	<input type="checkbox"/>	<input type="checkbox"/>	<input type="checkbox"/>	1LT1	A3
<input type="radio"/>	3	3	CX21	<input checked="" type="checkbox"/>	<input checked="" type="checkbox"/>	<input type="checkbox"/>	<input type="checkbox"/>	<input type="checkbox"/>	Y	0	1.6	<input checked="" type="checkbox"/>	<input type="checkbox"/>	<input type="checkbox"/>	<input type="checkbox"/>	<input type="checkbox"/>	<input checked="" type="checkbox"/>	<input type="checkbox"/>	<input type="checkbox"/>	<input type="checkbox"/>	<input type="checkbox"/>	1LT1	A4	
<input type="radio"/>	4	4	I	<input type="checkbox"/>	<input type="checkbox"/>	<input type="checkbox"/>	<input type="checkbox"/>	<input type="checkbox"/>				<input type="checkbox"/>	<input type="checkbox"/>	<input type="checkbox"/>	<input type="checkbox"/>	<input type="checkbox"/>	<input type="checkbox"/>	<input type="checkbox"/>	<input type="checkbox"/>	<input type="checkbox"/>	<input type="checkbox"/>	<input type="checkbox"/>	1LT1	B1
<input type="radio"/>	5	5	I	<input type="checkbox"/>	<input type="checkbox"/>	<input type="checkbox"/>	<input type="checkbox"/>	<input type="checkbox"/>				<input type="checkbox"/>	<input type="checkbox"/>	<input type="checkbox"/>	<input type="checkbox"/>	<input type="checkbox"/>	<input type="checkbox"/>	<input type="checkbox"/>	<input type="checkbox"/>	<input type="checkbox"/>	<input type="checkbox"/>	<input type="checkbox"/>	1LT1	B2
<input type="radio"/>	6	6	I	<input type="checkbox"/>	<input type="checkbox"/>	<input type="checkbox"/>	<input type="checkbox"/>	<input type="checkbox"/>				<input type="checkbox"/>	<input type="checkbox"/>	<input type="checkbox"/>	<input type="checkbox"/>	<input type="checkbox"/>	<input type="checkbox"/>	<input type="checkbox"/>	<input type="checkbox"/>	<input type="checkbox"/>	<input type="checkbox"/>	<input type="checkbox"/>	1LT1	B3
<input type="radio"/>	7	7	I	<input type="checkbox"/>	<input type="checkbox"/>	<input type="checkbox"/>	<input type="checkbox"/>	<input type="checkbox"/>				<input type="checkbox"/>	<input type="checkbox"/>	<input type="checkbox"/>	<input type="checkbox"/>	<input type="checkbox"/>	<input type="checkbox"/>	<input type="checkbox"/>	<input type="checkbox"/>	<input type="checkbox"/>	<input type="checkbox"/>	<input type="checkbox"/>	1LT1	B4

Add	Delete	Move	Clear Used By	Move to/from backplane
Manual Map Optimisation				

Works Order :
 EM Number : 4028
 Engineer : T Shaw
 Intersection : Durham Road Station lane Birtley

Inputs and Outputs

Inputs and Outputs

<input type="checkbox"/> Enable Signal Required Check boxes <input type="checkbox"/> Manual Allocation	<p style="text-align: center;">Port Number & Type</p> Port: <input style="width: 50px;" type="text" value="2"/> <div style="display: flex; justify-content: space-around; margin-top: 5px;"> <input type="radio"/> Inputs <input type="radio"/> Outputs <input checked="" type="radio"/> Inputs & Outputs </div>	<p style="text-align: center;">Card Type & Address</p> Serial IO 244 Card Address: 2
--	--	---

	DET No	Bit No	Type I or O	Name	Req'd	BP	Inv	U/D	Misc	DFM	DFM Group	Ext time	Used By								Term Block	Line No			
													Phs	UTC	SDE	Pri	HC	CC	IG	UD			LRT		
<input type="radio"/>	16	0	I	PBE1	<input checked="" type="checkbox"/>	<input type="checkbox"/>	<input type="checkbox"/>	<input type="checkbox"/>	<input type="checkbox"/>	N		0.0	<input checked="" type="checkbox"/>	<input type="checkbox"/>	<input type="checkbox"/>	<input type="checkbox"/>	<input type="checkbox"/>	<input type="checkbox"/>	<input type="checkbox"/>	<input type="checkbox"/>	<input type="checkbox"/>	<input type="checkbox"/>	11/O1	I-0	
<input type="radio"/>	17	1	I	PBE2	<input checked="" type="checkbox"/>	<input type="checkbox"/>	<input type="checkbox"/>	<input type="checkbox"/>	<input type="checkbox"/>	N		0.0	<input checked="" type="checkbox"/>	<input type="checkbox"/>	<input type="checkbox"/>	<input type="checkbox"/>	<input type="checkbox"/>	<input type="checkbox"/>	<input type="checkbox"/>	<input type="checkbox"/>	<input type="checkbox"/>	<input type="checkbox"/>	<input type="checkbox"/>	11/O1	I-1
<input type="radio"/>	18	2	I	PBE3	<input checked="" type="checkbox"/>	<input type="checkbox"/>	<input type="checkbox"/>	<input type="checkbox"/>	<input type="checkbox"/>	N		0.0	<input checked="" type="checkbox"/>	<input type="checkbox"/>	<input type="checkbox"/>	<input type="checkbox"/>	<input type="checkbox"/>	<input type="checkbox"/>	<input type="checkbox"/>	<input type="checkbox"/>	<input type="checkbox"/>	<input type="checkbox"/>	<input type="checkbox"/>	11/O1	I-2
<input type="radio"/>	19	3	I	MVA	<input checked="" type="checkbox"/>	<input type="checkbox"/>	<input type="checkbox"/>	<input type="checkbox"/>	<input type="checkbox"/>	A	0	1.0	<input checked="" type="checkbox"/>	<input type="checkbox"/>	<input type="checkbox"/>	<input type="checkbox"/>	<input type="checkbox"/>	<input type="checkbox"/>	<input type="checkbox"/>	<input type="checkbox"/>	<input type="checkbox"/>	<input type="checkbox"/>	<input type="checkbox"/>	11/O1	I-3
<input type="radio"/>	20	4	I	MVB	<input checked="" type="checkbox"/>	<input type="checkbox"/>	<input type="checkbox"/>	<input type="checkbox"/>	<input type="checkbox"/>	A	0	1.0	<input checked="" type="checkbox"/>	<input type="checkbox"/>	<input type="checkbox"/>	<input type="checkbox"/>	<input type="checkbox"/>	<input type="checkbox"/>	<input type="checkbox"/>	<input type="checkbox"/>	<input type="checkbox"/>	<input type="checkbox"/>	<input type="checkbox"/>	11/O1	I-4
<input type="radio"/>	21	5	I	MVD	<input checked="" type="checkbox"/>	<input type="checkbox"/>	<input type="checkbox"/>	<input type="checkbox"/>	<input type="checkbox"/>	A	0	1.0	<input checked="" type="checkbox"/>	<input type="checkbox"/>	<input type="checkbox"/>	<input type="checkbox"/>	<input type="checkbox"/>	<input type="checkbox"/>	<input type="checkbox"/>	<input type="checkbox"/>	<input type="checkbox"/>	<input type="checkbox"/>	<input type="checkbox"/>	11/O1	I-5
<input type="radio"/>	22	6	I		<input type="checkbox"/>	<input type="checkbox"/>	<input type="checkbox"/>	<input type="checkbox"/>	<input type="checkbox"/>				<input type="checkbox"/>	<input type="checkbox"/>	<input type="checkbox"/>	<input type="checkbox"/>	<input type="checkbox"/>	<input type="checkbox"/>	<input type="checkbox"/>	<input type="checkbox"/>	<input type="checkbox"/>	<input type="checkbox"/>	<input type="checkbox"/>	11/O1	I-6
<input type="radio"/>	23	7	I		<input type="checkbox"/>	<input type="checkbox"/>	<input type="checkbox"/>	<input type="checkbox"/>	<input type="checkbox"/>				<input type="checkbox"/>	<input type="checkbox"/>	<input type="checkbox"/>	<input type="checkbox"/>	<input type="checkbox"/>	<input type="checkbox"/>	<input type="checkbox"/>	<input type="checkbox"/>	<input type="checkbox"/>	<input type="checkbox"/>	<input type="checkbox"/>	11/O1	I-7

Add	Delete	Move	Clear Used By	Move to/from backplane
Manual Map Optimisation				

Works Order :
 EM Number : 4028
 Engineer : T Shaw
 Intersection : Durham Road Station lane Birtley

Aspect Drives

Aspect Drives

A-L M-X Y-F2

Phase Driver Card 1

	Used For	Term Block	Term No
A - Red	Phase	1TBA	1
A - Amber	Phase	1TBA	2
A - Green	Phase	1TBA	3
B - Red	Phase	1TBA	4
B - Amber	Phase	1TBA	5
B - Green	Phase	1TBA	6
C - Red	Phase	1TBA	7
C - Amber	Phase	1TBA	8
C - Green	Phase	1TBA	9
D - Red	Phase	1TBA	10
D - Amber	Phase	1TBA	11
D - Green	Phase	1TBA	12

Phase Driver Card 1

	Used For	Term Block	Term No
E - Red	Phase	1TBB	1
E - Amber	Phase	1TBB	2
E - Green	Phase	1TBB	3
F - Red			
F - Amber			
F - Green			
G - Red			
G - Amber			
G - Green			
H - Red			
H - Amber			
H - Green			

Phase Driver Card 2

	Used For	Term Block	Term No
I - Red			
I - Amber			
I - Green			
J - Red			
J - Amber			
J - Green			
K - Red			
K - Amber			
K - Green			
L - Red			
L - Amber			
L - Green			

Works Order :
 EM Number : 4028
 Engineer : T Shaw
 Intersection : Durham Road Station lane Birtley

I/O - DFM Group Timings

I/O - DFM Group Timings

Input Group	State	SETA	SET B	SET C	SET D
Group 0	Active (Mins)	<input type="text" value="60"/>	<input type="text" value="60"/>	<input type="text" value="60"/>	<input type="text" value="60"/>
	InActive (Hrs)	<input type="text" value="18"/>	<input type="text" value="18"/>	<input type="text" value="18"/>	<input type="text" value="18"/>
Group 1	Active (Mins)	<input type="text" value="30"/>	<input type="text" value="30"/>	<input type="text" value="30"/>	<input type="text" value="30"/>
	InActive (Hrs)	<input type="text" value="18"/>	<input type="text" value="18"/>	<input type="text" value="18"/>	<input type="text" value="18"/>
Group 2	Active (Mins)	<input type="text" value="30"/>	<input type="text" value="30"/>	<input type="text" value="30"/>	<input type="text" value="30"/>
	InActive (Hrs)	<input type="text" value="18"/>	<input type="text" value="18"/>	<input type="text" value="18"/>	<input type="text" value="18"/>
Group 3	Active (Mins)	<input type="text" value="30"/>	<input type="text" value="30"/>	<input type="text" value="30"/>	<input type="text" value="30"/>
	InActive (Hrs)	<input type="text" value="18"/>	<input type="text" value="18"/>	<input type="text" value="18"/>	<input type="text" value="18"/>
Group 4	Active (Mins)	<input type="text" value="30"/>	<input type="text" value="30"/>	<input type="text" value="30"/>	<input type="text" value="30"/>
	InActive (Hrs)	<input type="text" value="18"/>	<input type="text" value="18"/>	<input type="text" value="18"/>	<input type="text" value="18"/>
Group 5	Active (Mins)	<input type="text" value="30"/>	<input type="text" value="30"/>	<input type="text" value="30"/>	<input type="text" value="30"/>
	InActive (Hrs)	<input type="text" value="18"/>	<input type="text" value="18"/>	<input type="text" value="18"/>	<input type="text" value="18"/>
Group 6	Active (Mins)	<input type="text" value="30"/>	<input type="text" value="30"/>	<input type="text" value="30"/>	<input type="text" value="30"/>
	InActive (Hrs)	<input type="text" value="18"/>	<input type="text" value="18"/>	<input type="text" value="18"/>	<input type="text" value="18"/>
Group 7	Active (Mins)	<input type="text" value="30"/>	<input type="text" value="30"/>	<input type="text" value="30"/>	<input type="text" value="30"/>
	InActive (Hrs)	<input type="text" value="18"/>	<input type="text" value="18"/>	<input type="text" value="18"/>	<input type="text" value="18"/>

Note - 255 or blank disables DFM monitoring of that state (active or inactive) during that timeset (A to D)

Handset Limiting Values

State	Min	Max
Active (Mins)	<input type="text" value="0"/>	<input type="text" value="254"/>
InActive (Hrs)	<input type="text" value="0"/>	<input type="text" value="254"/>

Index

- 1 General Junction Data
 - 1.1 Administration
 - 1.2 Phases, Stages and Streams
 - 1.3 Facilities/Modes Enabled and Mode Priority Levels
 - 1.4 Phases in Stages
 - 1.5 Stages in Streams
- 2 Phases
 - 2.1 Phase Type and Conditions
 - 2.2 Opposing and Conflicting Phases
 - 2.3 Timings
 - 2.3.1 Phase Minimums, Maximums, Extensions, Ped Leaving Periods
 - 2.3.2 Phase Intergreen Times
 - 2.3.3 Intergreen Handset Limits
 - 2.3.4 Phase Timing Handset Ranges
 - 2.4 VA Demand and Extend Definitions
 - 2.5 Phase Internal/Revertive Demands
- 3 Stage Movements
 - 3.1 Stages - Prohibited, Alternative, Ignored Moves
 - 3.2 Stage Internal Demands/Pedestrian Window Times
 - 3.3 Phase Delays (No configuration data to print)
 - 3.4 Intergreen Delays (No configuration data to print)
- 4 Modes and Facilities - Detailed
 - 4.1 Fixed Time
 - 4.2 Cableless Linking
 - 4.2.1 CLF - Plan(s) (No configuration data to print)
 - 4.2.2 CLF - Base Time
 - 4.2.3 CLF - Demand Dependent Moves
 - 4.3 UTC and MOVA
 - 4.3.1 UTC General Data
 - 4.3.2 UTC Control and Reply Data Format
 - 4.3.3 UTC Data Definitions
 - 4.3.3.1 UTC Phase Demand and Extend Definitions
 - 4.3.3.2 UTC Stage and Mode Data Definitions
 - 4.3.3.3 UTC Demand Dependent Forces
 - 4.3.4 UTC and MOVA Detectors (No configuration data to print)
 - 4.4 Master Time Clock
 - 4.4.1 MTC - Time Switch Parameters
 - 4.4.2 MTC - Time Switch Parameters Array
 - 4.4.3 MTC - Day Type
 - 4.4.4 MTC - Timetable
 - 4.4.5 Holiday Clock - Special Days
 - 4.4.6 Holiday Clock - Special Holiday Periods
 - 4.5 Integral Lamp Monitoring
 - 4.5.1 LMU - General
 - 4.5.2 LMU - Sensors
 - 4.5.3 LMU Sensor Load Types
 - 4.5.4 RLM Additional Intergreens
 - 4.5.5 RLM Phase Inhibits
 - 4.6 Manual
 - 4.6.1 Manual Panel
 - 4.6.2 Manual Mode - Optional Phases Appearance (No configuration data to print)
 - 4.7 Reserve State
- 5 Conditioning Data
 - 5.1 Special Conditioning
 - 5.2 Special Conditioning Timers (No configuration data to print)
 - 5.3 Fault Log Flags
- 6 Special Instructions
- 7 I/O
 - 7.1 Call Cancel
 - 7.2 Inputs and Outputs
 - 7.3 Aspect Drives
 - 7.4 I/O - DFM Group Timings

Appendix 14

MTP Results Summary
MTP Results Summary

User and Project Details

Project:	
Title:	
Location:	
File name:	Birtley Lane.lsg3x
Author:	
Company:	
Address:	
Notes:	

Phase Diagram

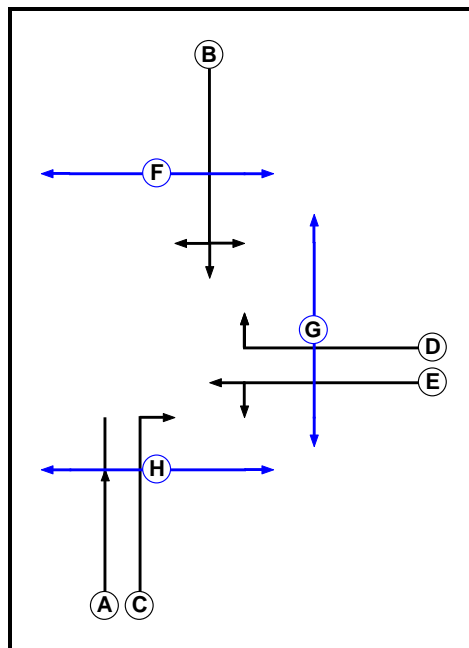

MTP Results Summary

Phase Input Data

Phase Name	Phase Type	Assoc. Phase	Street Min	Cont Min
A	Traffic		7	7
B	Traffic		7	7
C	Traffic		7	7
D	Traffic		7	7
E	Traffic		7	7
F	Pedestrian		7	7
G	Pedestrian		7	7
H	Pedestrian		7	7

Phase Intergreens Matrix

		Starting Phase							
		A	B	C	D	E	F	G	H
Terminating Phase	A	-	-	6	-	11	11	11	
	B	-	8	6	6	11	11	11	
	C	-	7	6	-	11	11	11	
	D	6	6	7	-	11	11	11	
	E	-	6	-	-	11	11	11	
	F	5	5	5	5	5	-	-	
	G	5	5	5	5	5	-	-	
	H	5	5	5	5	5	-	-	

Stage Diagram

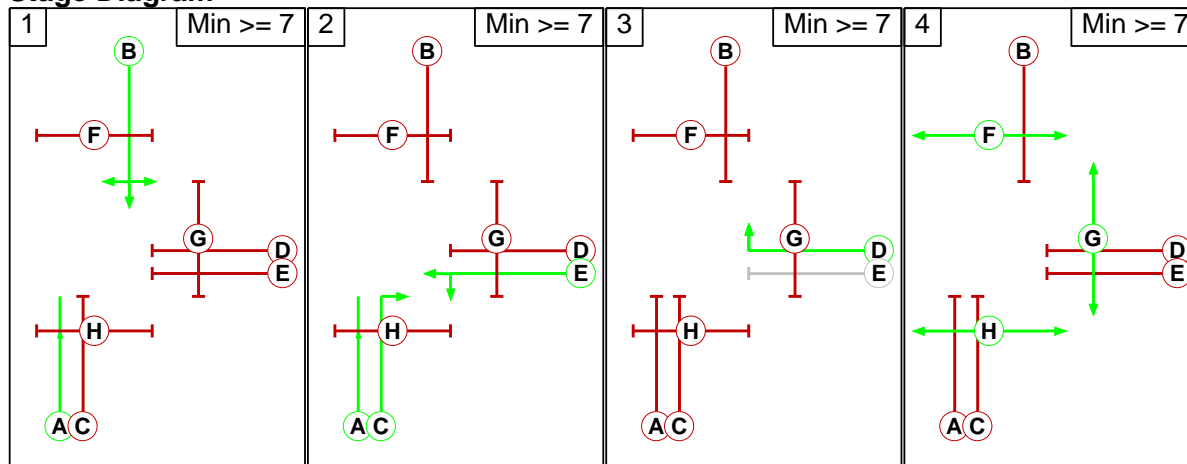

Phase Delays

Term. Stage	Start Stage	Phase	Type	Value	Cont value
There are no Phase Delays defined					

Scenario 1: 'Scenario 1' (FG1: '2022 Baseline AM', Plan 1: 'Network Control Plan 1')

Stage Sequence Diagram

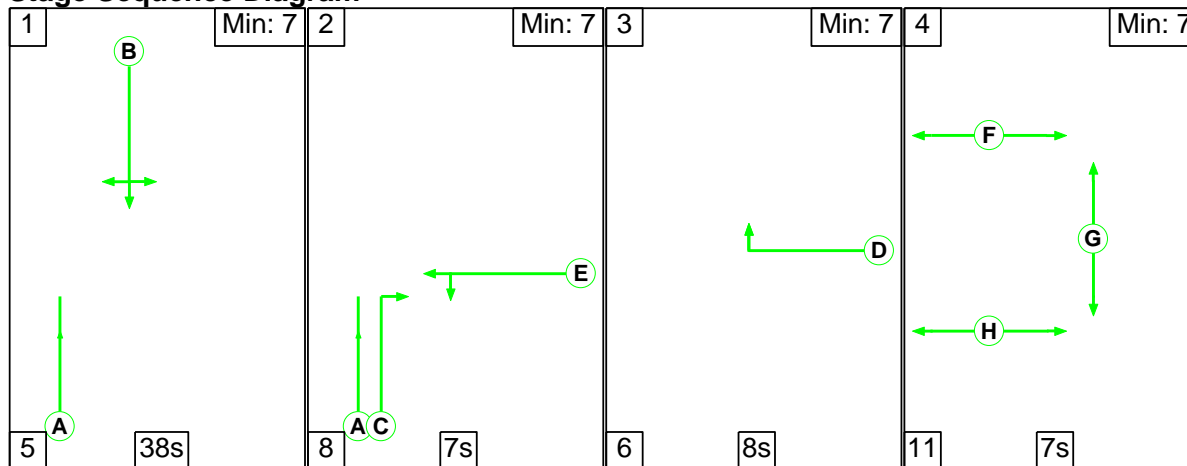

Lane Input Data

Junction: A167/Birtley Lane/Craig Street												
Lane	Lane Type	Phases	Start Disp.	End Disp.	Physical Length (PCU)	Sat Flow Type	Def User Saturation Flow (PCU/Hr)	Lane Width (m)	Gradient	Nearside Lane	Turns	Turning Radius (m)
1/1 (Durham Road Southbound)	U	B	2	3	60.0	Geom	-	3.30	0.00	Y	Arm 5 Left	Inf
											Arm 6 Ahead	Inf
											Arm 7 Right	Inf
2/1 (Birtley Lane)	U	E	2	3	60.0	Geom	-	2.00	0.00	Y	Arm 6 Left	Inf
2/2 (Birtley Lane)	U	D	2	3	13.9	Geom	-	2.60	0.00	Y	Arm 7 Ahead	Inf
3/1 (Durham Road Northbound)	U		2	3	60.0	Geom	-	2.90	0.00	Y	Arm 4 Ahead	Inf
											Arm 7 Left	Inf
3/2 (Durham Road Northbound)	U	C	2	3	5.0	Geom	-	2.70	0.00	Y	Arm 5 Right	Inf
4/1	U		2	3	60.0	Inf	-	-	-	-	-	-
4/2	U		2	3	60.0	Inf	-	-	-	-	-	-
5/1	U		2	3	60.0	Inf	-	-	-	-	-	-
6/1	U		2	3	60.0	Inf	-	-	-	-	-	-
7/1	U		2	3	60.0	Inf	-	-	-	-	-	-

Give-Way Lane Input Data

Junction: A167/Birtley Lane/Craig Street
There are no Opposed Lanes in this Junction

MTP Results Summary

Traffic Flow Groups

Flow Group	Start Time	End Time	Duration	Formula
1: '2022 Baseline AM'	08:00	09:00	01:00	

Traffic Flows, Actual

Actual Flow :

	Destination					
	A	B	C	D	Tot.	
Origin	A	0	239	378	2	619
	B	139	0	121	5	265
	C	186	93	0	9	288
	D	0	0	0	0	0
	Tot.	325	332	499	16	1172

MTP Results Summary

Network Results

Item	Lane Description	Lane Type	Full Phase	Arrow Phase	Num Greens	Total Green (s)	Arrow Green (s)	Demand Flow (pcu)	Sat Flow (pcu/Hr)	Capacity (pcu)	Deg Sat (%)	Turners In Gaps (pcu)	Turners When Unopposed (pcu)	Turners In Intergreen (pcu)	Total Delay (pcuHr)	Mean Max Queue (pcu)
Network	-	-	-		-	-	-	-	-	-	74.1%	0	0	0	11.7	-
A167/Birtley Lane/Craig Street	-	-	-		-	-	-	-	-	-	74.1%	0	0	0	11.7	-
1/1	Durham Road Southbound Left Ahead Right	U	B		1	38	-	619	1945	843	73.4%	-	-	-	5.0	14.1
2/1	Birtley Lane Left Ahead	U	E		1	9	-	126	1815	202	62.5%	-	-	-	2.2	3.8
2/2	Birtley Lane Right	U	D		1	8	-	139	1875	187	74.1%	-	-	-	2.9	4.7
3/1+3/2	Durham Road Northbound Ahead Right Left	U	- C		-	-	-	288	1905:1885	351+168	55.5 : 55.5%	-	-	-	1.6	2.8
		C1			PRC for Signalled Lanes (%): 21.4		21.4	Total Delay for Signalled Lanes (pcuHr): 10.04				Cycle Time (s): 90				
				PRC Over All Lanes (%): 21.4				Total Delay Over All Lanes(pcuHr): 11.68								

MTP Results Summary
Network Layout Diagram

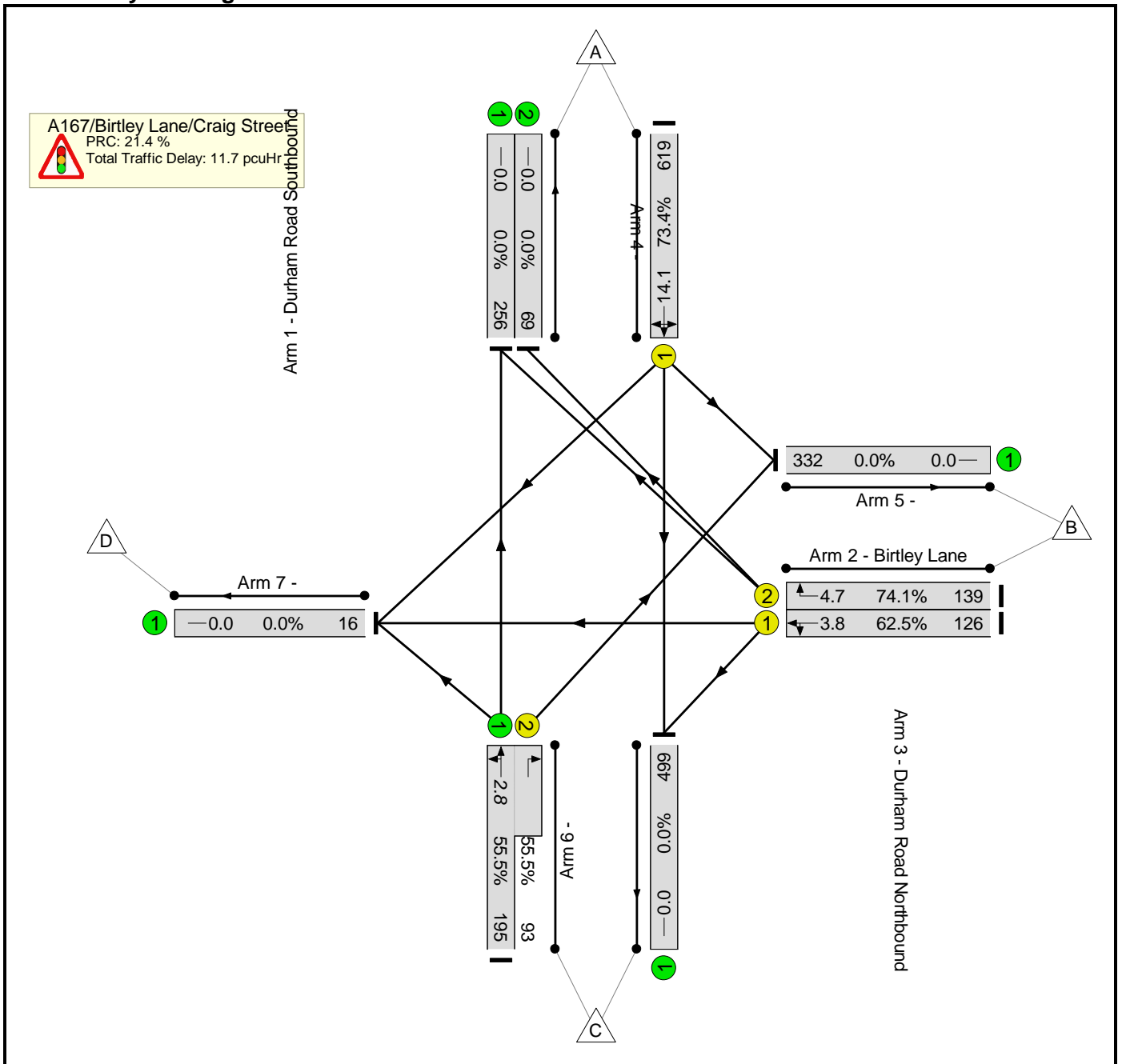

Scenario 2: 'Scenario 2' (FG2: '2022 Baseline PM', Plan 1: 'Network Control Plan 1')
Stage Sequence Diagram

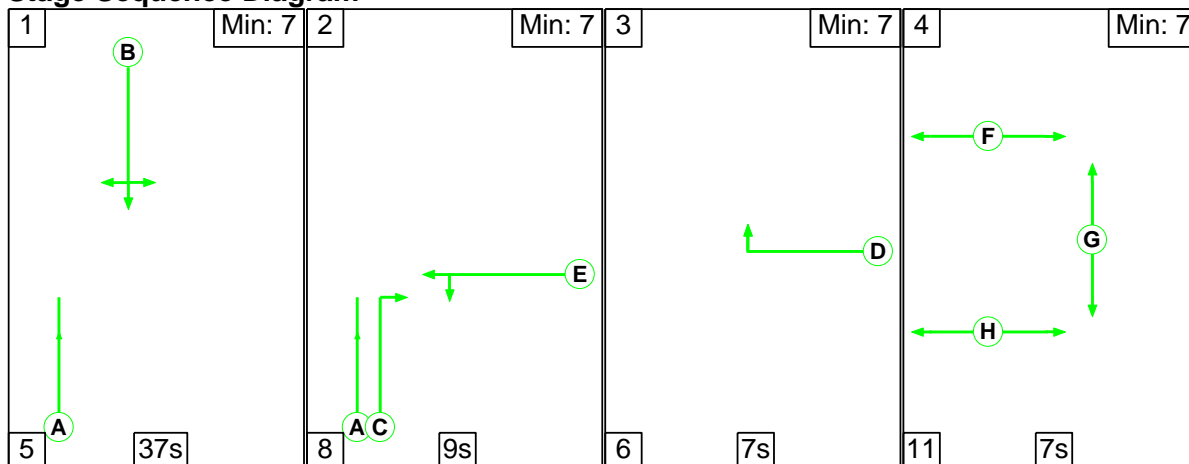

MTP Results Summary

Lane Input Data

Junction: A167/Birtley Lane/Craig Street												
Lane	Lane Type	Phases	Start Disp.	End Disp.	Physical Length (PCU)	Sat Flow Type	Def User Saturation Flow (PCU/Hr)	Lane Width (m)	Gradient	Nearside Lane	Turns	Turning Radius (m)
1/1 (Durham Road Southbound)	U	B	2	3	60.0	Geom	-	3.30	0.00	Y	Arm 5 Left	Inf
											Arm 6 Ahead	Inf
											Arm 7 Right	Inf
2/1 (Birtley Lane)	U	E	2	3	60.0	Geom	-	2.00	0.00	Y	Arm 6 Left	Inf
											Arm 7 Ahead	Inf
2/2 (Birtley Lane)	U	D	2	3	13.9	Geom	-	2.60	0.00	Y	Arm 4 Right	Inf
3/1 (Durham Road Northbound)	U		2	3	60.0	Geom	-	2.90	0.00	Y	Arm 4 Ahead	Inf
											Arm 7 Left	Inf
3/2 (Durham Road Northbound)	U	C	2	3	5.0	Geom	-	2.70	0.00	Y	Arm 5 Right	Inf
4/1	U		2	3	60.0	Inf	-	-	-	-	-	-
4/2	U		2	3	60.0	Inf	-	-	-	-	-	-
5/1	U		2	3	60.0	Inf	-	-	-	-	-	-
6/1	U		2	3	60.0	Inf	-	-	-	-	-	-
7/1	U		2	3	60.0	Inf	-	-	-	-	-	-

Give-Way Lane Input Data

Junction: A167/Birtley Lane/Craig Street
There are no Opposed Lanes in this Junction

Traffic Flow Groups

Flow Group	Start Time	End Time	Duration	Formula
2: '2022 Baseline PM'	17:00	18:00	01:00	

Traffic Flows, Actual

Actual Flow :

Origin	Destination					
	A	B	C	D	Tot.	
A	0	154	470	0	624	
B	128	0	182	1	311	
C	335	108	0	0	443	
D	0	0	0	0	0	
Tot.	463	262	652	1	1378	

MTP Results Summary

MTP Results Summary

Network Results

Item	Lane Description	Lane Type	Full Phase	Arrow Phase	Num Greens	Total Green (s)	Arrow Green (s)	Demand Flow (pcu)	Sat Flow (pcu/Hr)	Capacity (pcu)	Deg Sat (%)	Turners In Gaps (pcu)	Turners When Unopposed (pcu)	Turners In Intergreen (pcu)	Total Delay (pcuHr)	Mean Max Queue (pcu)						
Network	-	-	-		-	-	-	-	-	-	76.8%	0	0	0	13.5	-						
A167/Birtley Lane/Craig Street	-	-	-		-	-	-	-	-	-	76.8%	0	0	0	13.5	-						
1/1	Durham Road Southbound Left Ahead Right	U	B		1	37	-	624	1945	821	76.0%	-	-	-	5.4	14.7						
2/1	Birtley Lane Left Ahead	U	E		1	11	-	183	1815	242	75.6%	-	-	-	3.4	5.8						
2/2	Birtley Lane Right	U	D		1	7	-	128	1875	167	76.8%	-	-	-	3.0	4.7						
3/1+3/2	Durham Road Northbound Ahead Right Left	U	- C		-	-	-	443	1905:1885	620+200	54.0 : 54.0%	-	-	-	1.7	3.1						
		C1	PRC for Signalled Lanes (%):		17.2		PRC Over All Lanes (%):		17.2		Total Delay for Signalled Lanes (pcuHr):		11.74		Total Delay Over All Lanes(pcuHr):		13.46		Cycle Time (s):		90	

MTP Results Summary
Network Layout Diagram

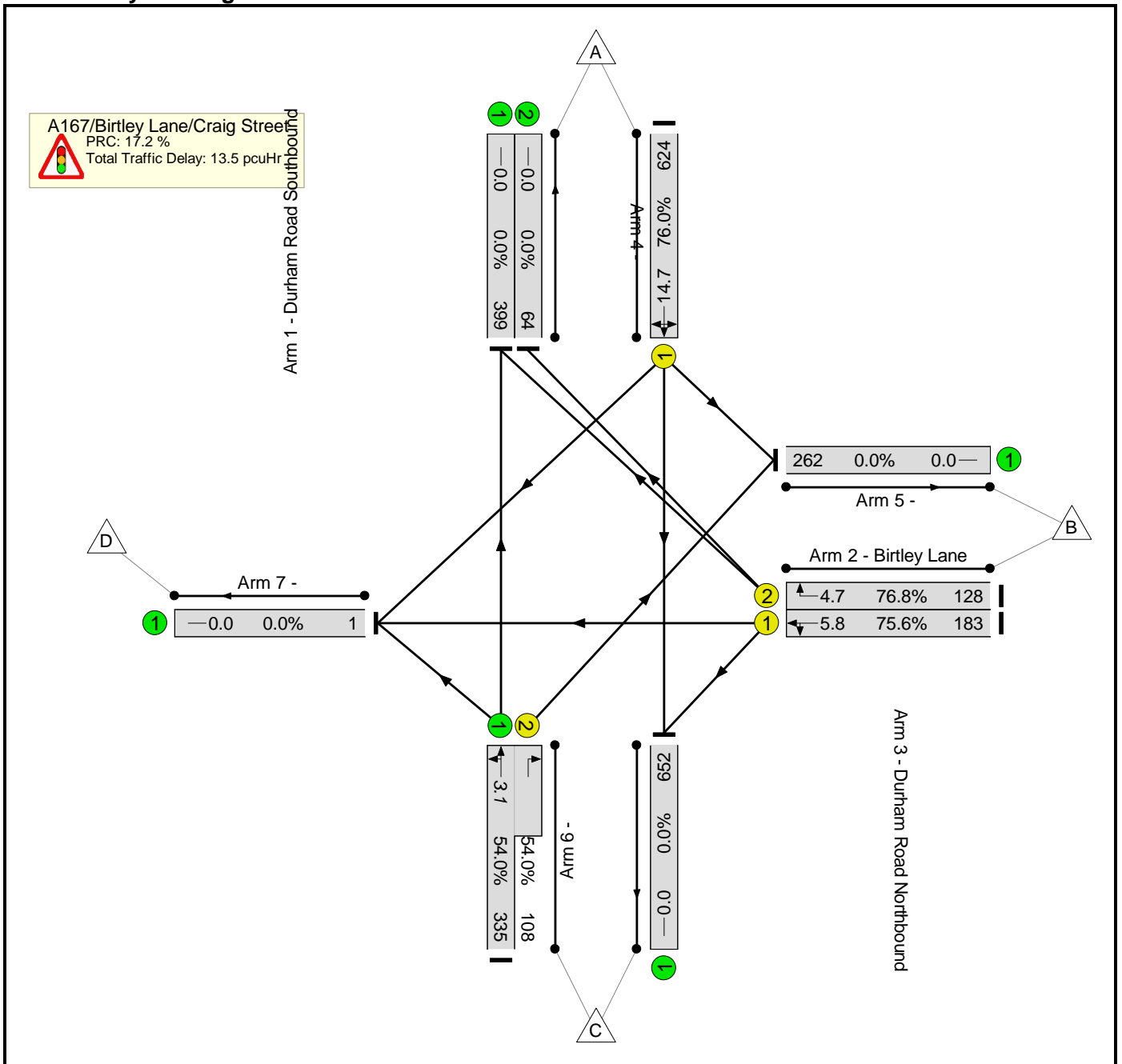

Scenario 3: 'Scenario 3' (FG3: '2028 Baseline AM', Plan 1: 'Network Control Plan 1')
Stage Sequence Diagram

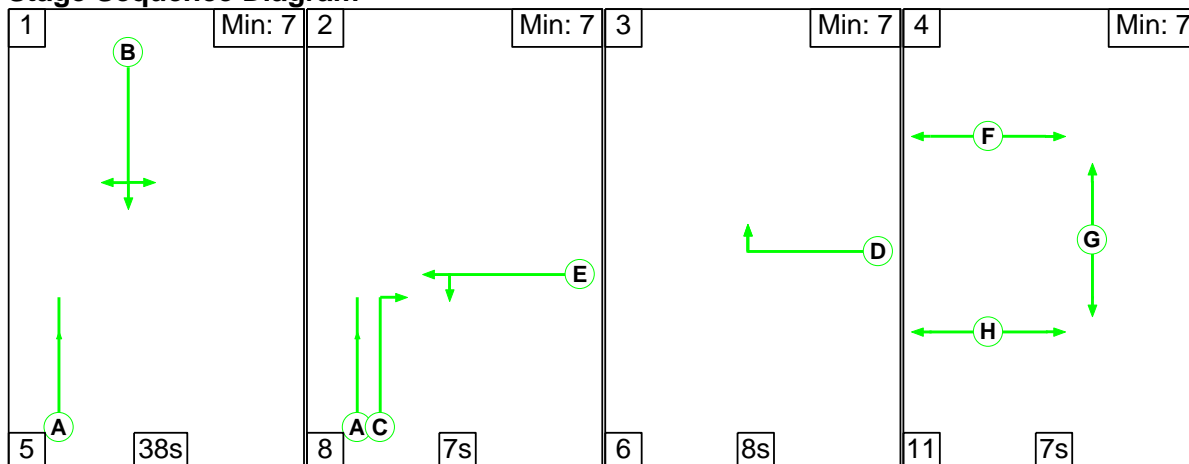

Lane Input Data

Junction: A167/Birtley Lane/Craig Street												
Lane	Lane Type	Phases	Start Disp.	End Disp.	Physical Length (PCU)	Sat Flow Type	Def User Saturation Flow (PCU/Hr)	Lane Width (m)	Gradient	Nearside Lane	Turns	Turning Radius (m)
1/1 (Durham Road Southbound)	U	B	2	3	60.0	Geom	-	3.30	0.00	Y	Arm 5 Left	Inf
											Arm 6 Ahead	Inf
											Arm 7 Right	Inf
2/1 (Birtley Lane)	U	E	2	3	60.0	Geom	-	2.00	0.00	Y	Arm 6 Left	Inf
											Arm 7 Ahead	Inf
2/2 (Birtley Lane)	U	D	2	3	13.9	Geom	-	2.60	0.00	Y	Arm 4 Right	Inf
3/1 (Durham Road Northbound)	U		2	3	60.0	Geom	-	2.90	0.00	Y	Arm 4 Ahead	Inf
											Arm 7 Left	Inf
3/2 (Durham Road Northbound)	U	C	2	3	5.0	Geom	-	2.70	0.00	Y	Arm 5 Right	Inf
4/1	U		2	3	60.0	Inf	-	-	-	-	-	-
4/2	U		2	3	60.0	Inf	-	-	-	-	-	-
5/1	U		2	3	60.0	Inf	-	-	-	-	-	-
6/1	U		2	3	60.0	Inf	-	-	-	-	-	-
7/1	U		2	3	60.0	Inf	-	-	-	-	-	-

Give-Way Lane Input Data

Junction: A167/Birtley Lane/Craig Street
There are no Opposed Lanes in this Junction

Traffic Flow Groups

Flow Group	Start Time	End Time	Duration	Formula
3: '2028 Baseline AM'	08:00	09:00	01:00	

Traffic Flows, Actual

Actual Flow :

Origin	Destination					
	A	B	C	D	Tot.	
A	0	252	398	2	652	
B	146	0	127	5	278	
C	196	97	0	9	302	
D	0	0	0	0	0	
Tot.	342	349	525	16	1232	

MTP Results Summary

MTP Results Summary

Network Results

Item	Lane Description	Lane Type	Full Phase	Arrow Phase	Num Greens	Total Green (s)	Arrow Green (s)	Demand Flow (pcu)	Sat Flow (pcu/Hr)	Capacity (pcu)	Deg Sat (%)	Turners In Gaps (pcu)	Turners When Unopposed (pcu)	Turners In Intergreen (pcu)	Total Delay (pcuHr)	Mean Max Queue (pcu)						
Network	-	-	-		-	-	-	-	-	-	77.9%	0	0	0	12.9	-						
A167/Birtley Lane/Craig Street	-	-	-		-	-	-	-	-	-	77.9%	0	0	0	12.9	-						
1/1	Durham Road Southbound Left Ahead Right	U	B		1	38	-	652	1945	843	77.4%	-	-	-	5.6	15.4						
2/1	Birtley Lane Left Ahead	U	E		1	9	-	132	1815	202	65.5%	-	-	-	2.3	4.1						
2/2	Birtley Lane Right	U	D		1	8	-	146	1875	187	77.9%	-	-	-	3.2	5.2						
3/1+3/2	Durham Road Northbound Ahead Right Left	U	- C		-	-	-	302	1905:1885	354+168	57.9 : 57.9%	-	-	-	1.7	3.0						
		C1	PRC for Signalled Lanes (%):		15.6		PRC Over All Lanes (%):		15.6		Total Delay for Signalled Lanes (pcuHr):		11.18		Total Delay Over All Lanes(pcuHr):		12.92		Cycle Time (s):		90	

MTP Results Summary
Network Layout Diagram

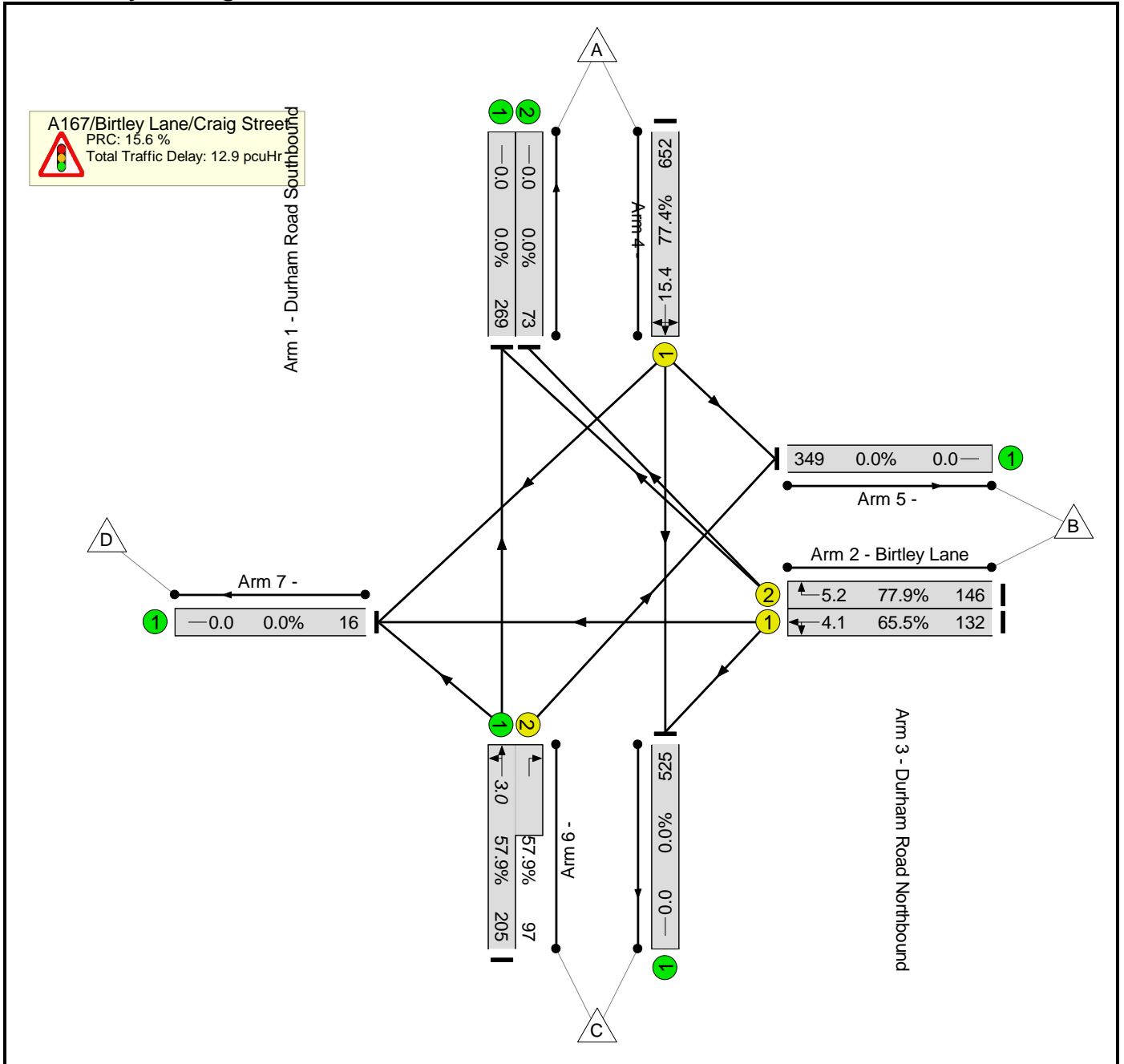

Scenario 4: 'Scenario 4' (FG4: '2028 Baseline PM', Plan 1: 'Network Control Plan 1')

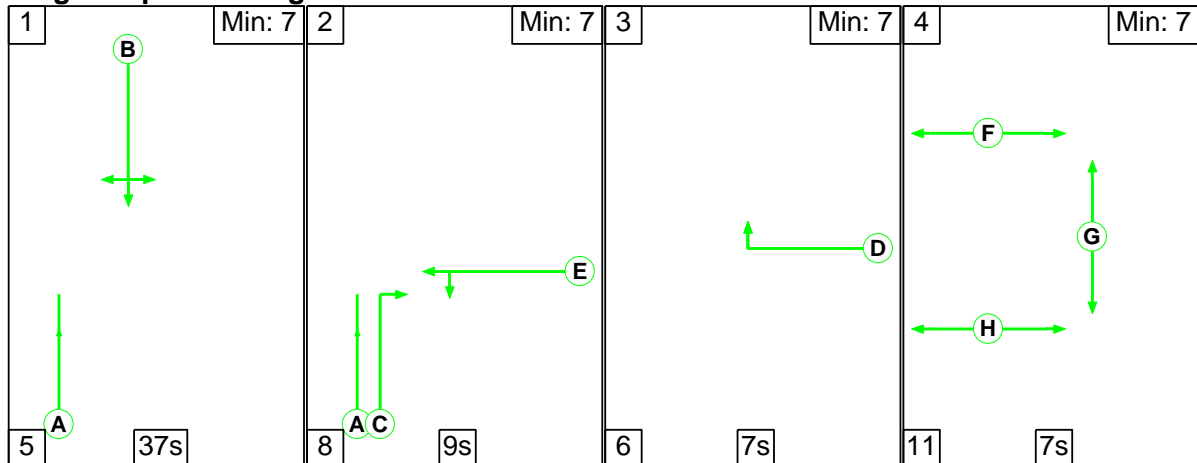

Lane Input Data

Junction: A167/Birtley Lane/Craig Street												
Lane	Lane Type	Phases	Start Disp.	End Disp.	Physical Length (PCU)	Sat Flow Type	Def User Saturation Flow (PCU/Hr)	Lane Width (m)	Gradient	Nearside Lane	Turns	Turning Radius (m)
1/1 (Durham Road Southbound)	U	B	2	3	60.0	Geom	-	3.30	0.00	Y	Arm 5 Left	Inf
											Arm 6 Ahead	Inf
											Arm 7 Right	Inf
2/1 (Birtley Lane)	U	E	2	3	60.0	Geom	-	2.00	0.00	Y	Arm 6 Left	Inf
											Arm 7 Ahead	Inf
2/2 (Birtley Lane)	U	D	2	3	13.9	Geom	-	2.60	0.00	Y	Arm 4 Right	Inf
3/1 (Durham Road Northbound)	U		2	3	60.0	Geom	-	2.90	0.00	Y	Arm 4 Ahead	Inf
											Arm 7 Left	Inf
3/2 (Durham Road Northbound)	U	C	2	3	5.0	Geom	-	2.70	0.00	Y	Arm 5 Right	Inf
4/1	U		2	3	60.0	Inf	-	-	-	-	-	-
4/2	U		2	3	60.0	Inf	-	-	-	-	-	-
5/1	U		2	3	60.0	Inf	-	-	-	-	-	-
6/1	U		2	3	60.0	Inf	-	-	-	-	-	-
7/1	U		2	3	60.0	Inf	-	-	-	-	-	-

Give-Way Lane Input Data

Junction: A167/Birtley Lane/Craig Street
There are no Opposed Lanes in this Junction

Traffic Flow Groups

Flow Group	Start Time	End Time	Duration	Formula
4: '2028 Baseline PM'	17:00	18:00	01:00	

Traffic Flows, Actual

Actual Flow :

Origin	Destination					
	A	B	C	D	Tot.	
A	0	162	494	0	656	
B	135	0	191	1	327	
C	352	113	0	0	465	
D	0	0	0	0	0	
Tot.	487	275	685	1	1448	

MTP Results Summary

MTP Results Summary

Network Results

Item	Lane Description	Lane Type	Full Phase	Arrow Phase	Num Greens	Total Green (s)	Arrow Green (s)	Demand Flow (pcu)	Sat Flow (pcu/Hr)	Capacity (pcu)	Deg Sat (%)	Turners In Gaps (pcu)	Turners When Unopposed (pcu)	Turners In Intergreen (pcu)	Total Delay (pcuHr)	Mean Max Queue (pcu)
Network	-	-	-		-	-	-	-	-	-	81.0%	0	0	0	15.1	-
A167/Birtley Lane/Craig Street	-	-	-		-	-	-	-	-	-	81.0%	0	0	0	15.1	-
1/1	Durham Road Southbound Left Ahead Right	U	B		1	37	-	656	1945	821	79.9%	-	-	-	6.1	16.2
2/1	Birtley Lane Left Ahead	U	E		1	11	-	192	1815	242	79.3%	-	-	-	3.8	6.4
2/2	Birtley Lane Right	U	D		1	7	-	135	1875	167	81.0%	-	-	-	3.4	5.2
3/1+3/2	Durham Road Northbound Ahead Right Left	U	- C		-	-	-	465	1905:1885	623+200	56.5 : 56.5%	-	-	-	1.8	3.3
<p style="text-align: center;">C1 PRC for Signalled Lanes (%): 11.1 Total Delay for Signalled Lanes (pcuHr): 13.29 Cycle Time (s): 90 PRC Over All Lanes (%): 11.1 Total Delay Over All Lanes(pcuHr): 15.13</p>																

MTP Results Summary
Network Layout Diagram

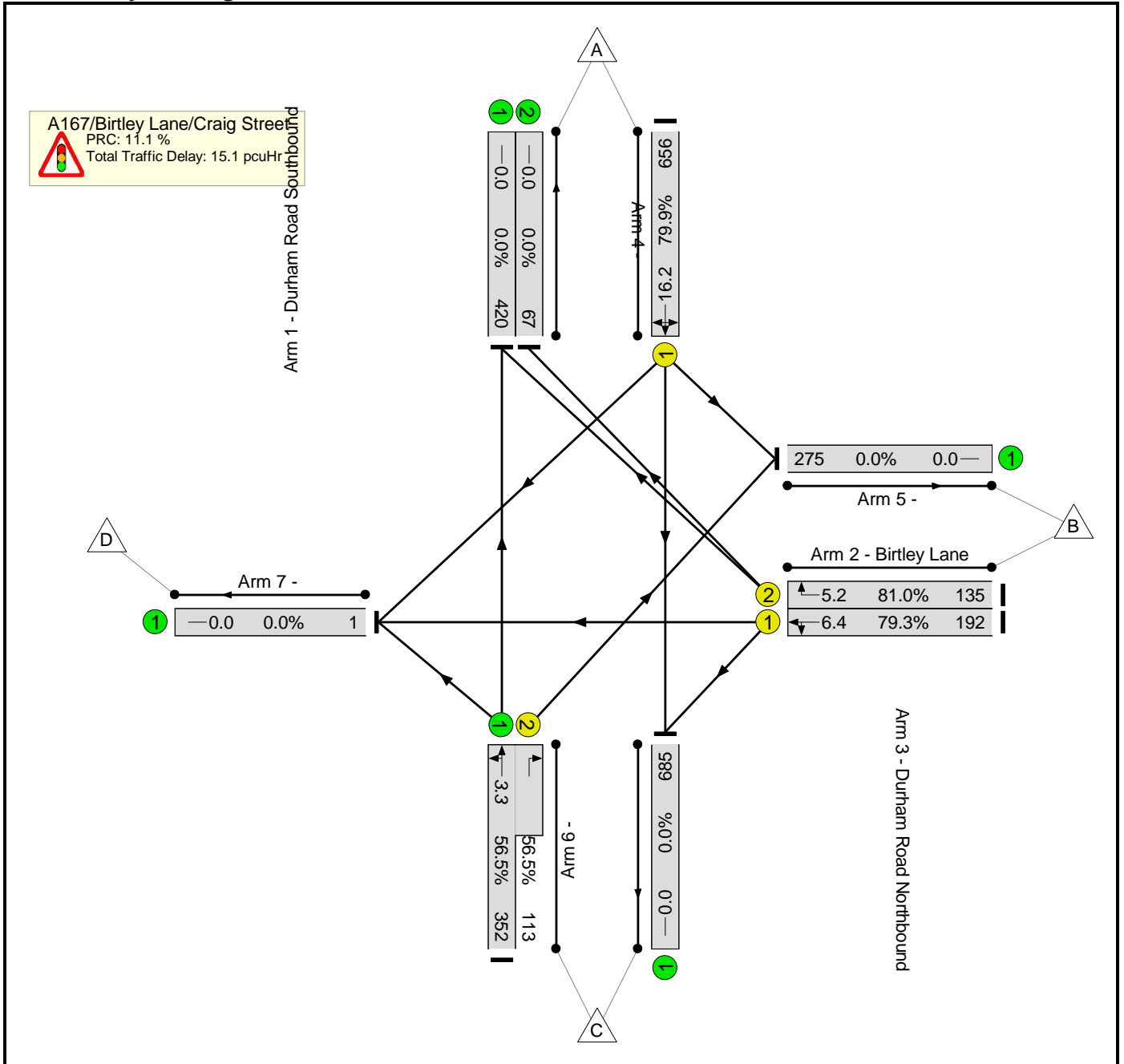

Scenario 5: 'Scenario 5' (FG5: '2028 Baseline + CD + Dev AM', Plan 1: 'Network Control Plan 1')
Stage Sequence Diagram

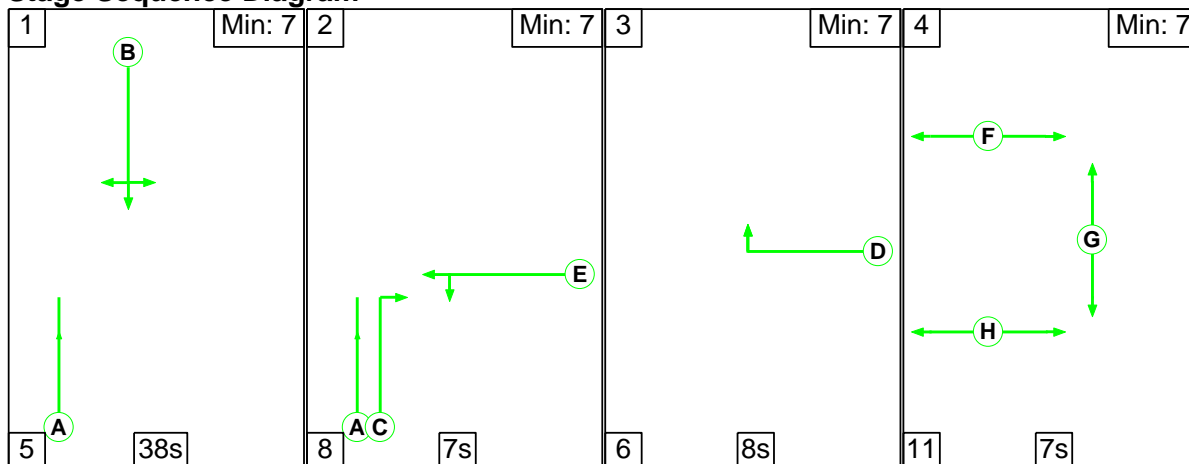

Lane Input Data

Junction: A167/Birtley Lane/Craig Street												
Lane	Lane Type	Phases	Start Disp.	End Disp.	Physical Length (PCU)	Sat Flow Type	Def User Saturation Flow (PCU/Hr)	Lane Width (m)	Gradient	Nearside Lane	Turns	Turning Radius (m)
1/1 (Durham Road Southbound)	U	B	2	3	60.0	Geom	-	3.30	0.00	Y	Arm 5 Left	Inf
											Arm 6 Ahead	Inf
											Arm 7 Right	Inf
2/1 (Birtley Lane)	U	E	2	3	60.0	Geom	-	2.00	0.00	Y	Arm 6 Left	Inf
											Arm 7 Ahead	Inf
2/2 (Birtley Lane)	U	D	2	3	13.9	Geom	-	2.60	0.00	Y	Arm 4 Right	Inf
3/1 (Durham Road Northbound)	U		2	3	60.0	Geom	-	2.90	0.00	Y	Arm 4 Ahead	Inf
											Arm 7 Left	Inf
3/2 (Durham Road Northbound)	U	C	2	3	5.0	Geom	-	2.70	0.00	Y	Arm 5 Right	Inf
4/1	U		2	3	60.0	Inf	-	-	-	-	-	-
4/2	U		2	3	60.0	Inf	-	-	-	-	-	-
5/1	U		2	3	60.0	Inf	-	-	-	-	-	-
6/1	U		2	3	60.0	Inf	-	-	-	-	-	-
7/1	U		2	3	60.0	Inf	-	-	-	-	-	-

Give-Way Lane Input Data

Junction: A167/Birtley Lane/Craig Street
There are no Opposed Lanes in this Junction

Traffic Flow Groups

Flow Group	Start Time	End Time	Duration	Formula
5: '2028 Baseline + CD + Dev AM'	08:00	09:00	01:00	

Traffic Flows, Actual

Actual Flow :

Origin	Destination					
	A	B	C	D	Tot.	
A	0	280	427	2	709	
B	159	0	131	5	295	
C	208	113	0	9	330	
D	0	0	0	0	0	
Tot.	367	393	558	16	1334	

MTP Results Summary

MTP Results Summary

Network Results

Item	Lane Description	Lane Type	Full Phase	Arrow Phase	Num Greens	Total Green (s)	Arrow Green (s)	Demand Flow (pcu)	Sat Flow (pcu/Hr)	Capacity (pcu)	Deg Sat (%)	Turners In Gaps (pcu)	Turners When Unopposed (pcu)	Turners In Intergreen (pcu)	Total Delay (pcuHr)	Mean Max Queue (pcu)						
Network	-	-	-		-	-	-	-	-	-	84.8%	0	0	0	15.9	-						
A167/Birtley Lane/Craig Street	-	-	-		-	-	-	-	-	-	84.8%	0	0	0	15.9	-						
1/1	Durham Road Southbound Left Ahead Right	U	B		1	38	-	709	1945	843	84.1%	-	-	-	7.0	18.3						
2/1	Birtley Lane Left Ahead	U	E		1	9	-	136	1815	202	67.4%	-	-	-	2.5	4.3						
2/2	Birtley Lane Right	U	D		1	8	-	159	1875	187	84.8%	-	-	-	4.1	6.3						
3/1+3/2	Durham Road Northbound Ahead Right Left	U	- C		-	-	-	330	1905:1885	322+168	67.4 : 67.4%	-	-	-	2.3	3.8						
		C1	PRC for Signalled Lanes (%):		6.1		PRC Over All Lanes (%):		6.1		Total Delay for Signalled Lanes (pcuHr):		13.64		Total Delay Over All Lanes(pcuHr):		15.91		Cycle Time (s):		90	

MTP Results Summary
Network Layout Diagram

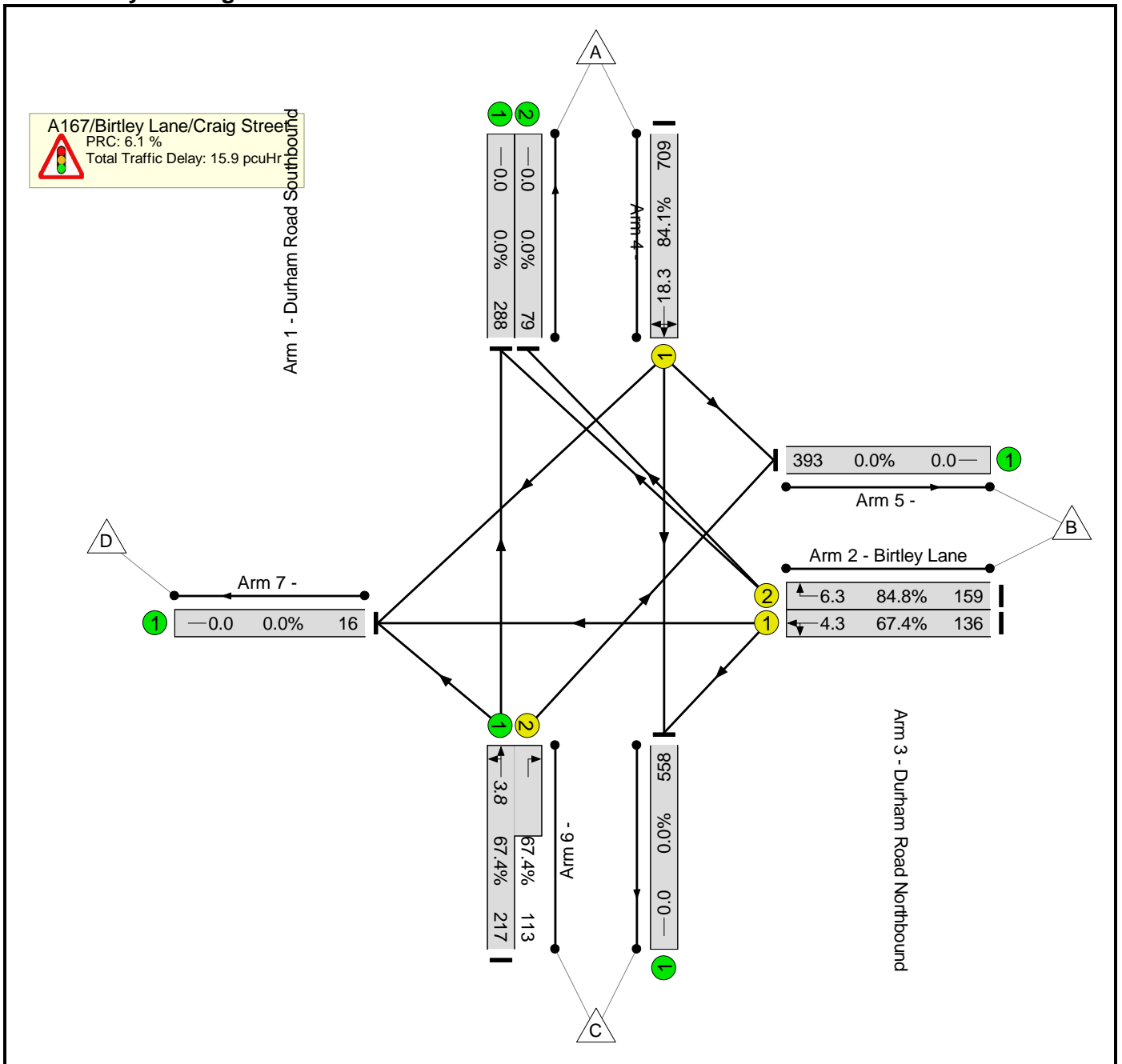

Scenario 6: 'Scenario 6' (FG6: '2028 Baseline + CD + Dev PM', Plan 1: 'Network Control Plan 1')

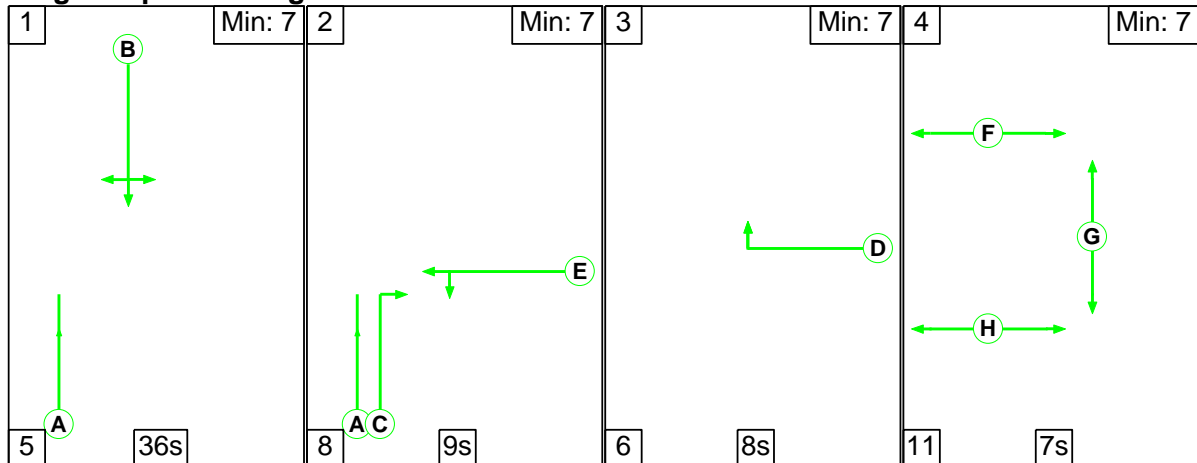

Lane Input Data

Junction: A167/Birtley Lane/Craig Street												
Lane	Lane Type	Phases	Start Disp.	End Disp.	Physical Length (PCU)	Sat Flow Type	Def User Saturation Flow (PCU/Hr)	Lane Width (m)	Gradient	Nearside Lane	Turns	Turning Radius (m)
1/1 (Durham Road Southbound)	U	B	2	3	60.0	Geom	-	3.30	0.00	Y	Arm 5 Left	Inf
											Arm 6 Ahead	Inf
											Arm 7 Right	Inf
2/1 (Birtley Lane)	U	E	2	3	60.0	Geom	-	2.00	0.00	Y	Arm 6 Left	Inf
											Arm 7 Ahead	Inf
2/2 (Birtley Lane)	U	D	2	3	13.9	Geom	-	2.60	0.00	Y	Arm 4 Right	Inf
3/1 (Durham Road Northbound)	U		2	3	60.0	Geom	-	2.90	0.00	Y	Arm 4 Ahead	Inf
											Arm 7 Left	Inf
3/2 (Durham Road Northbound)	U	C	2	3	5.0	Geom	-	2.70	0.00	Y	Arm 5 Right	Inf
4/1	U		2	3	60.0	Inf	-	-	-	-	-	-
4/2	U		2	3	60.0	Inf	-	-	-	-	-	-
5/1	U		2	3	60.0	Inf	-	-	-	-	-	-
6/1	U		2	3	60.0	Inf	-	-	-	-	-	-
7/1	U		2	3	60.0	Inf	-	-	-	-	-	-

Give-Way Lane Input Data

Junction: A167/Birtley Lane/Craig Street
There are no Opposed Lanes in this Junction

Traffic Flow Groups

Flow Group	Start Time	End Time	Duration	Formula
6: '2028 Baseline + CD + Dev PM'	17:00	18:00	01:00	

Traffic Flows, Actual

Actual Flow :

Origin	Destination					
	A	B	C	D	Tot.	
A	0	177	521	0	698	
B	158	0	206	1	365	
C	383	121	0	0	504	
D	0	0	0	0	0	
Tot.	541	298	727	1	1567	

MTP Results Summary

MTP Results Summary

Network Results

Item	Lane Description	Lane Type	Full Phase	Arrow Phase	Num Greens	Total Green (s)	Arrow Green (s)	Demand Flow (pcu)	Sat Flow (pcu/Hr)	Capacity (pcu)	Deg Sat (%)	Turners In Gaps (pcu)	Turners When Unopposed (pcu)	Turners In Intergreen (pcu)	Total Delay (pcuHr)	Mean Max Queue (pcu)						
Network	-	-	-		-	-	-	-	-	-	87.3%	0	0	0	18.8	-						
A167/Birtley Lane/Craig Street	-	-	-		-	-	-	-	-	-	87.3%	0	0	0	18.8	-						
1/1	Durham Road Southbound Left Ahead Right	U	B		1	36	-	698	1945	800	87.3%	-	-	-	7.9	19.1						
2/1	Birtley Lane Left Ahead	U	E		1	11	-	207	1815	242	85.5%	-	-	-	4.8	7.6						
2/2	Birtley Lane Right	U	D		1	8	-	158	1875	187	84.3%	-	-	-	4.1	6.2						
3/1+3/2	Durham Road Northbound Ahead Right Left	U	- C		-	-	-	504	1905:1885	633+200	60.5 : 60.5%	-	-	-	2.0	3.6						
		C1	PRC for Signalled Lanes (%):		3.1		PRC Over All Lanes (%):		3.1		Total Delay for Signalled Lanes (pcuHr):		16.78		Total Delay Over All Lanes(pcuHr):		18.82		Cycle Time (s):		90	

MTP Results Summary
Network Layout Diagram

A167/Birtley Lane/Craig Street
 PRC: 3.1 %
 Total Traffic Delay: 18.8 pcuHr

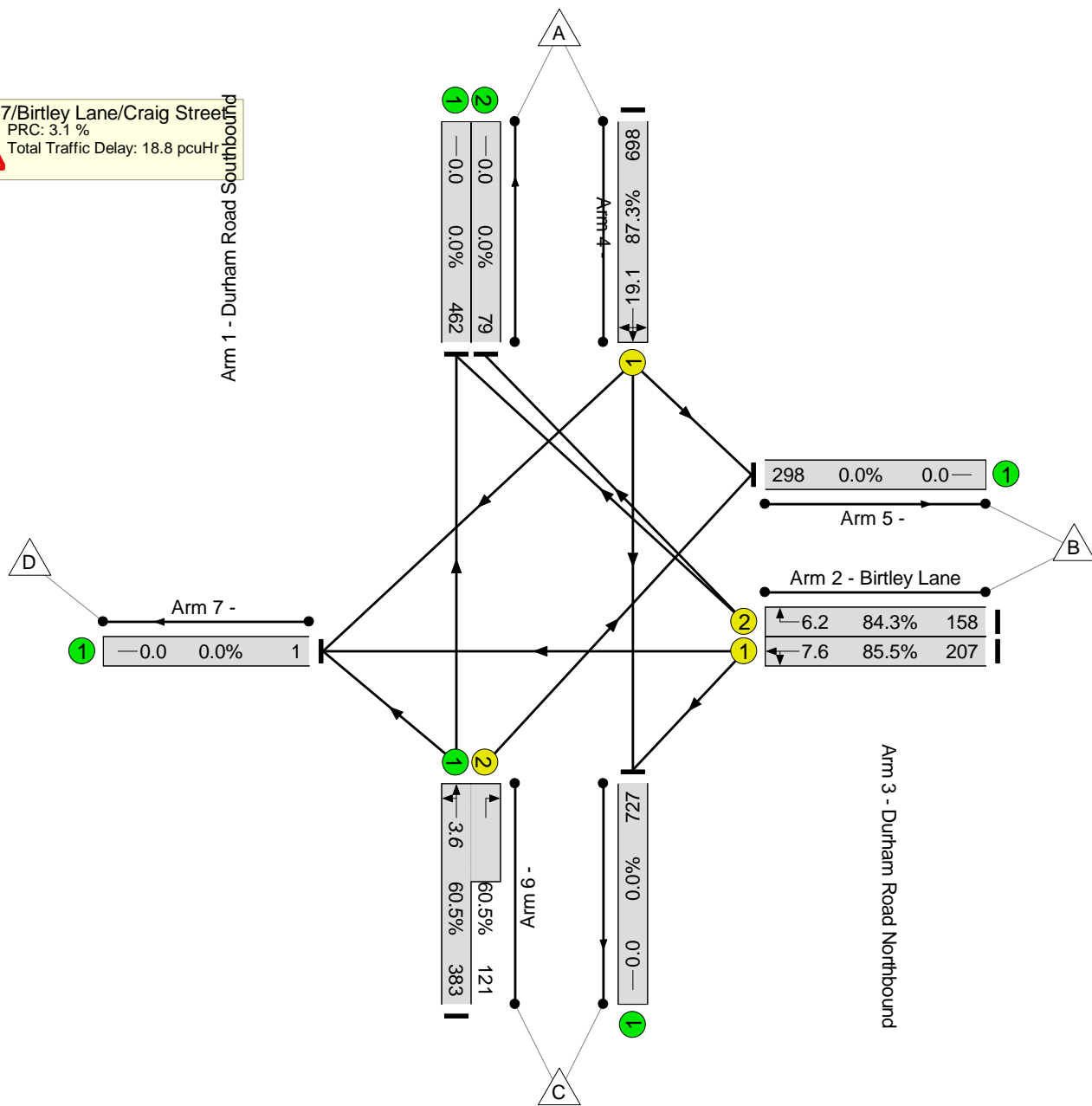
Arm 3 - Durham Road Northbound

MTP Results Summary
MTP Results Summary

User and Project Details

Project:	
Title:	
Location:	
File name:	Station Lane.lsg3x
Author:	
Company:	
Address:	
Notes:	

Phase Diagram

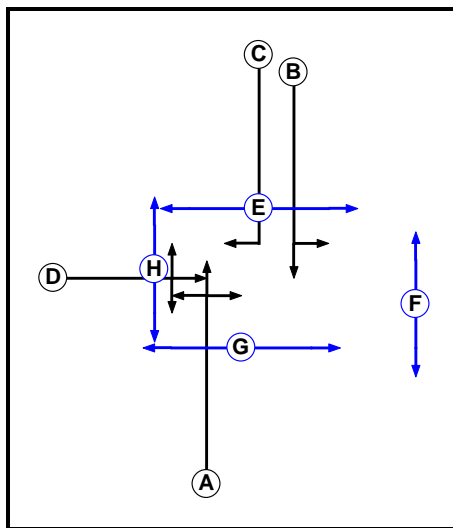

Phase Input Data

Phase Name	Phase Type	Assoc. Phase	Street Min	Cont Min
A	Traffic		7	7
B	Traffic		7	7
C	Traffic		7	7
D	Traffic		7	7
E	Pedestrian		7	7
F	Pedestrian		7	7
G	Pedestrian		7	7
H	Pedestrian		7	7

Phase Intergreens Matrix

		Starting Phase							
		A	B	C	D	E	F	G	H
Terminating Phase	A	-	5	6	7	7	7	7	7
	B	-	-	6	7	7	7	7	7
	C	5	-	6	7	7	7	7	7
	D	5	5	5	-	7	7	7	7
	E	9	9	9	8	-	-	-	-
	F	9	9	9	8	-	-	-	-
	G	9	9	9	8	-	-	-	-
	H	9	9	9	8	-	-	-	-

Stage Diagram

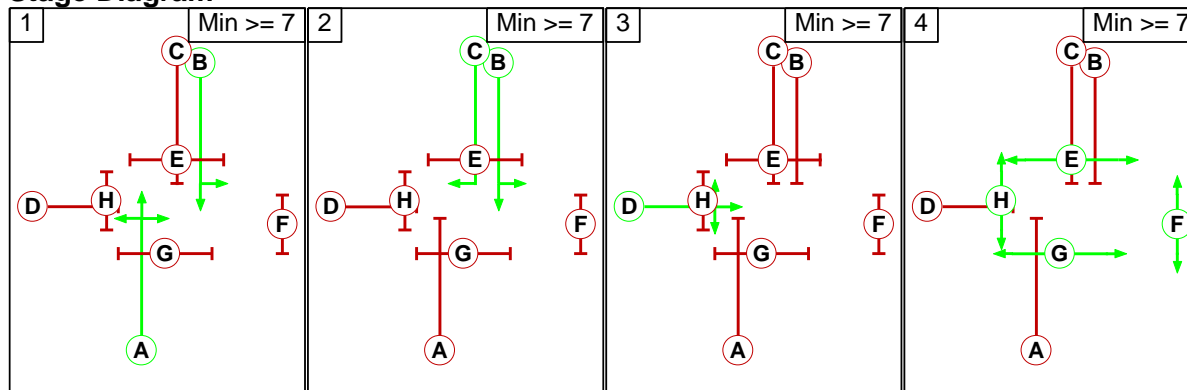

Phase Delays

Term. Stage	Start Stage	Phase	Type	Value	Cont value
There are no Phase Delays defined					

MTP Results Summary

Scenario 1: 'Scenario 1' (FG1: '2022 Baseline AM', Plan 1: 'Network Control Plan 1')

Stage Sequence Diagram

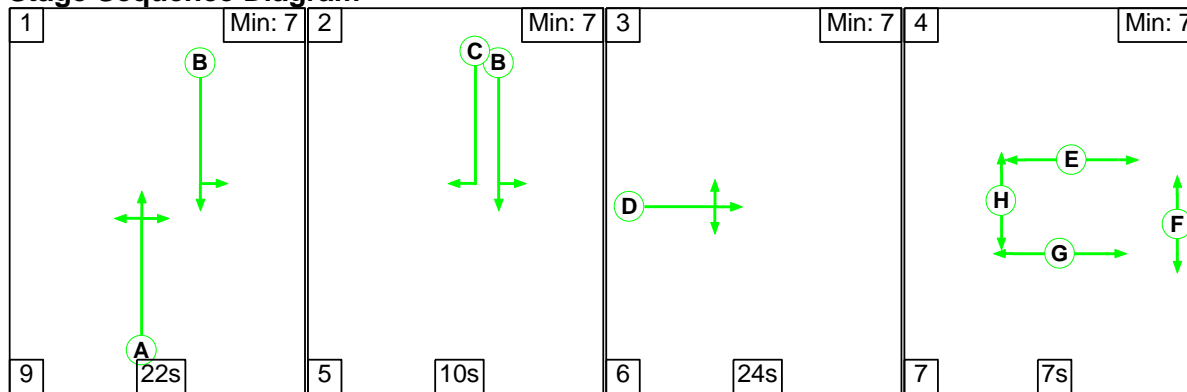

Lane Input Data

Junction: A167/The Avenue/Station Lane												
Lane	Lane Type	Phases	Start Disp.	End Disp.	Physical Length (PCU)	Sat Flow Type	Def User Saturation Flow (PCU/Hr)	Lane Width (m)	Gradient	Nearside Lane	Turns	Turning Radius (m)
1/1 (Durham Road Southbound)	U	B	2	3	60.0	Geom	-	2.70	0.00	Y	Arm 4 Ahead	Inf
											Arm 7 Left	Inf
1/2 (Durham Road Southbound)	U	C	2	3	60.0	Geom	-	3.00	0.00	Y	Arm 5 Right	Inf
2/1 (Durham Road Northbound)	U	A	2	3	60.0	Geom	-	3.60	0.00	Y	Arm 5 Left	Inf
2/2 (Durham Road Northbound)	U	A	2	3	5.0	Geom	-	3.30	0.00	Y	Arm 6 Ahead	Inf
											Arm 7 Right	Inf
3/1 (Station Lane)	U	D	2	3	60.0	Geom	-	4.00	0.00	Y	Arm 4 Right	Inf
											Arm 6 Left	Inf
4/1	U		2	3	60.0	Inf	-	-	-	-	-	-
5/1	U		2	3	60.0	Inf	-	-	-	-	-	-
6/1	U		2	3	60.0	Inf	-	-	-	-	-	-
7/1	U		2	3	60.0	Inf	-	-	-	-	-	-

Give-Way Lane Input Data

Junction: A167/The Avenue/Station Lane
 There are no Opposed Lanes in this Junction

MTP Results Summary

Traffic Flow Groups

Flow Group	Start Time	End Time	Duration	Formula
1: '2022 Baseline AM'	08:00	09:00	01:00	

Traffic Flows, Actual

Actual Flow :

	Destination					
	A	B	C	D	Tot.	
Origin	A	0	322	162	16	500
	B	224	0	223	23	470
	C	84	148	0	154	386
	D	0	0	0	0	0
	Tot.	308	470	385	193	1356

MTP Results Summary

Network Results

Item	Lane Description	Lane Type	Full Phase	Arrow Phase	Num Greens	Total Green (s)	Arrow Green (s)	Demand Flow (pcu)	Sat Flow (pcu/Hr)	Capacity (pcu)	Deg Sat (%)	Turners In Gaps (pcu)	Turners When Unopposed (pcu)	Turners In Intergreen (pcu)	Total Delay (pcuHr)	Mean Max Queue (pcu)
Network	-	-	-		-	-	-	-	-	-	69.2%	0	0	0	13.9	-
A167/The Avenue/Station Lane	-	-	-		-	-	-	-	-	-	69.2%	0	0	0	13.9	-
1/1	Durham Road Southbound Ahead Left	U	B		1	37	-	338	1885	796	42.5%	-	-	-	2.1	6.3
1/2	Durham Road Southbound Right	U	C		1	10	-	162	1915	234	69.2%	-	-	-	2.8	5.0
2/1+2/2	Durham Road Northbound Left Ahead Right	U	A		1	22	-	470	1975:1945	325+360	68.6 : 68.6%	-	-	-	4.8	6.6
3/1	Station Lane Right Left Ahead	U	D		1	24	-	386	2015	560	69.0%	-	-	-	4.2	9.7
C1						PRC for Signalled Lanes (%):	30.0	Total Delay for Signalled Lanes (pcuHr):			13.88	Cycle Time (s): 90				
						PRC Over All Lanes (%):	30.0	Total Delay Over All Lanes(pcuHr):			13.88					

MTP Results Summary
Network Layout Diagram

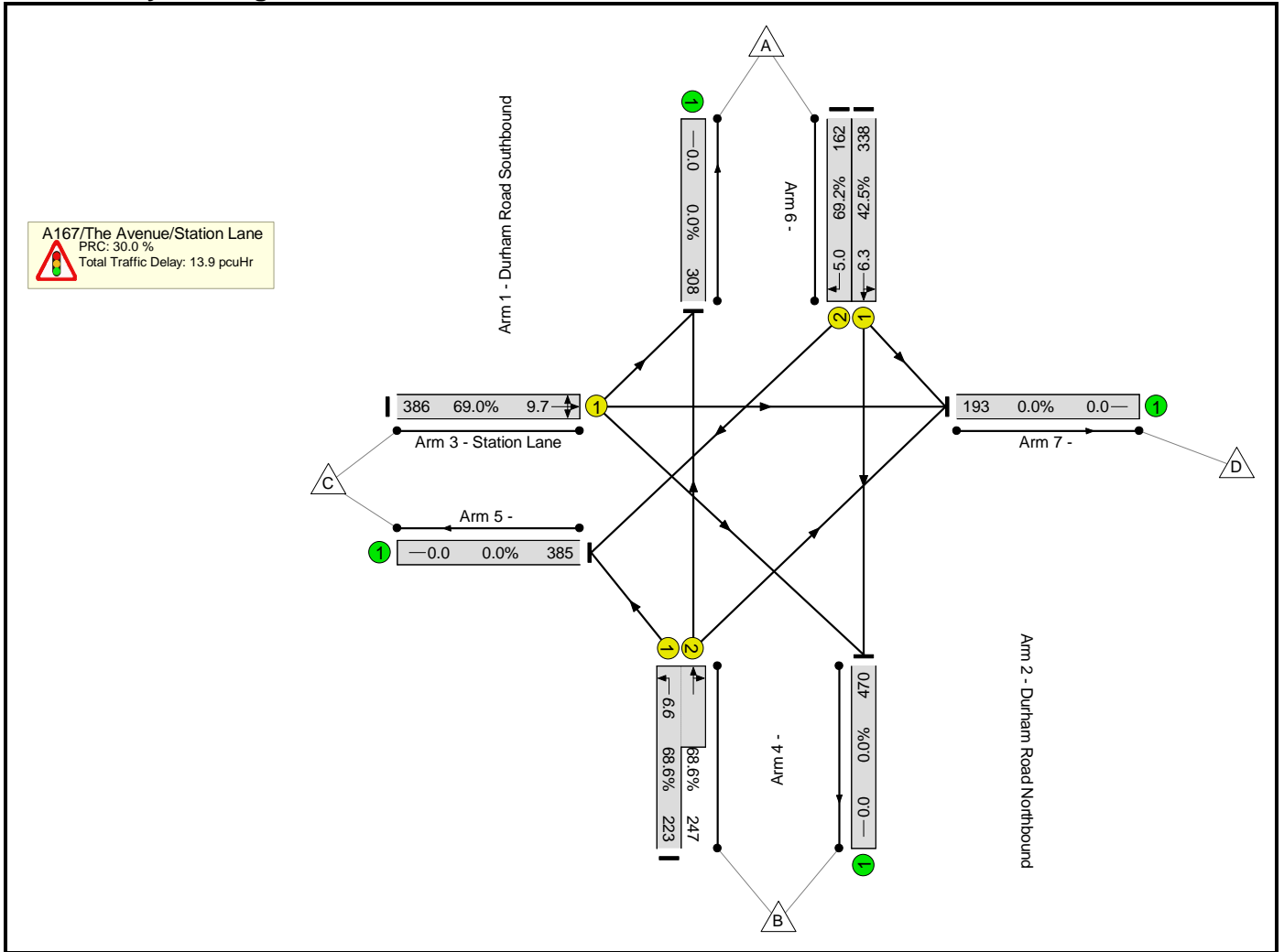

Scenario 2: 'Scenario 2' (FG2: '2022 Baseline PM', Plan 1: 'Network Control Plan 1')

Stage Sequence Diagram

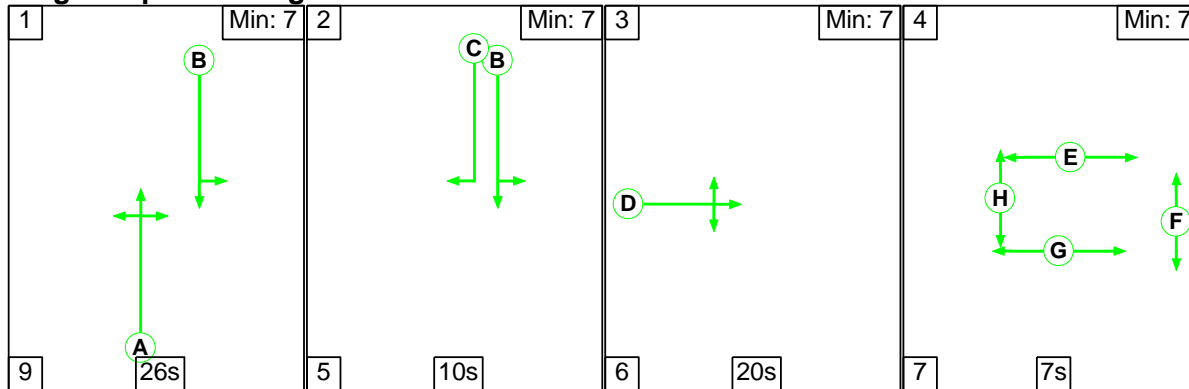

Lane Input Data

Junction: A167/The Avenue/Station Lane												
Lane	Lane Type	Phases	Start Disp.	End Disp.	Physical Length (PCU)	Sat Flow Type	Def User Saturation Flow (PCU/Hr)	Lane Width (m)	Gradient	Nearside Lane	Turns	Turning Radius (m)
1/1 (Durham Road Southbound)	U	B	2	3	60.0	Geom	-	2.70	0.00	Y	Arm 4 Ahead	Inf
											Arm 7 Left	Inf
1/2 (Durham Road Southbound)	U	C	2	3	60.0	Geom	-	3.00	0.00	Y	Arm 5 Right	Inf
2/1 (Durham Road Northbound)	U	A	2	3	60.0	Geom	-	3.60	0.00	Y	Arm 5 Left	Inf
2/2 (Durham Road Northbound)	U	A	2	3	5.0	Geom	-	3.30	0.00	Y	Arm 6 Ahead	Inf
											Arm 7 Right	Inf
3/1 (Station Lane)	U	D	2	3	60.0	Geom	-	4.00	0.00	Y	Arm 4 Right	Inf
											Arm 6 Left	Inf
											Arm 7 Ahead	Inf
4/1	U		2	3	60.0	Inf	-	-	-	-	-	-
5/1	U		2	3	60.0	Inf	-	-	-	-	-	-
6/1	U		2	3	60.0	Inf	-	-	-	-	-	-
7/1	U		2	3	60.0	Inf	-	-	-	-	-	-

Give-Way Lane Input Data

Junction: A167/The Avenue/Station Lane
There are no Opposed Lanes in this Junction

Traffic Flow Groups

Flow Group	Start Time	End Time	Duration	Formula
2: '2022 Baseline PM'	17:00	18:00	01:00	

Traffic Flows, Actual

Actual Flow :

	Destination					
	A	B	C	D	Tot.	
Origin	A	0	470	169	20	659
	B	332	0	142	11	485
	C	104	178	0	64	346
	D	0	0	0	0	0
	Tot.	436	648	311	95	1490

MTP Results Summary

Network Results

Item	Lane Description	Lane Type	Full Phase	Arrow Phase	Num Greens	Total Green (s)	Arrow Green (s)	Demand Flow (pcu)	Sat Flow (pcu/Hr)	Capacity (pcu)	Deg Sat (%)	Turners In Gaps (pcu)	Turners When Unopposed (pcu)	Turners In Intergreen (pcu)	Total Delay (pcuHr)	Mean Max Queue (pcu)
Network	-	-	-		-	-	-	-	-	-	73.6%	0	0	0	15.3	-
A167/The Avenue/Station Lane	-	-	-		-	-	-	-	-	-	73.6%	0	0	0	15.3	-
1/1	Durham Road Southbound Ahead Left	U	B		1	41	-	490	1885	880	55.7%	-	-	-	3.0	9.3
1/2	Durham Road Southbound Right	U	C		1	10	-	169	1915	234	72.2%	-	-	-	3.0	5.3
2/1+2/2	Durham Road Northbound Left Ahead Right	U	A		1	26	-	485	1975:1945	197+476	72.0 : 72.0%	-	-	-	4.8	9.7
3/1	Station Lane Right Left Ahead	U	D		1	20	-	346	2015	470	73.6%	-	-	-	4.4	9.3
C1						PRC for Signalled Lanes (%):	22.3	Total Delay for Signalled Lanes (pcuHr):			15.29	Cycle Time (s): 90				
						PRC Over All Lanes (%):	22.3	Total Delay Over All Lanes(pcuHr):			15.29					

MTP Results Summary
Network Layout Diagram

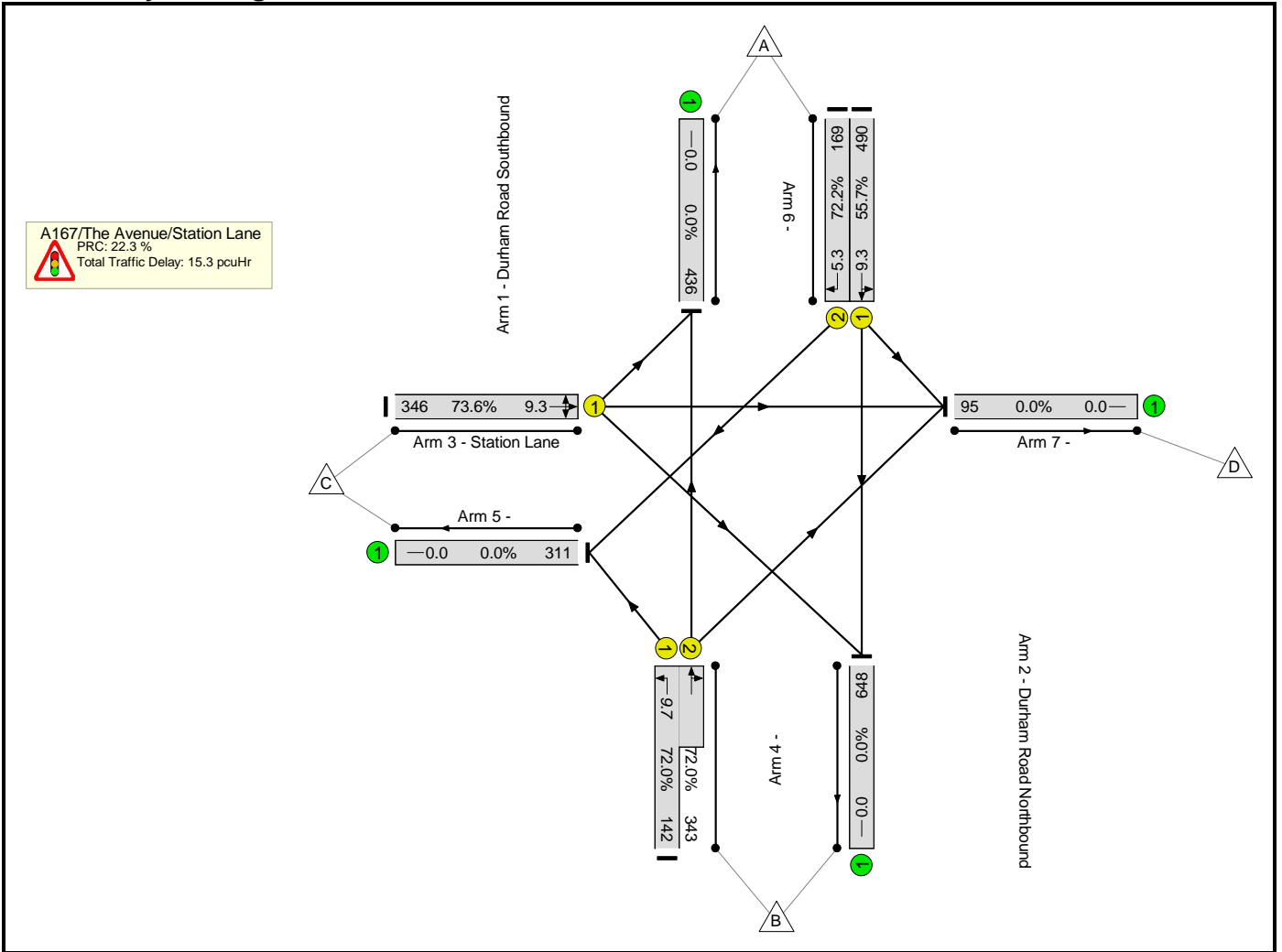

Scenario 3: 'Scenario 3' (FG3: '2028 Baseline AM', Plan 1: 'Network Control Plan 1')

Stage Sequence Diagram

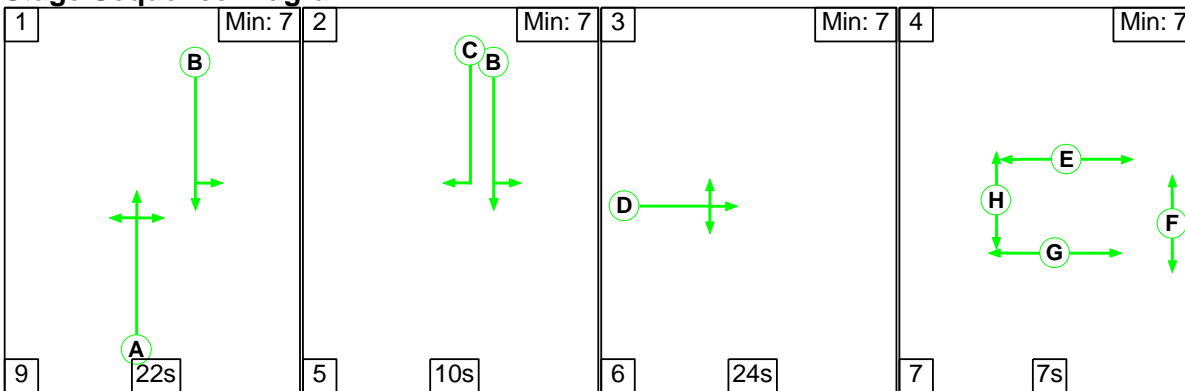

Lane Input Data

Junction: A167/The Avenue/Station Lane												
Lane	Lane Type	Phases	Start Disp.	End Disp.	Physical Length (PCU)	Sat Flow Type	Def User Saturation Flow (PCU/Hr)	Lane Width (m)	Gradient	Nearside Lane	Turns	Turning Radius (m)
1/1 (Durham Road Southbound)	U	B	2	3	60.0	Geom	-	2.70	0.00	Y	Arm 4 Ahead	Inf
											Arm 7 Left	Inf
1/2 (Durham Road Southbound)	U	C	2	3	60.0	Geom	-	3.00	0.00	Y	Arm 5 Right	Inf
2/1 (Durham Road Northbound)	U	A	2	3	60.0	Geom	-	3.60	0.00	Y	Arm 5 Left	Inf
2/2 (Durham Road Northbound)	U	A	2	3	5.0	Geom	-	3.30	0.00	Y	Arm 6 Ahead	Inf
											Arm 7 Right	Inf
3/1 (Station Lane)	U	D	2	3	60.0	Geom	-	4.00	0.00	Y	Arm 4 Right	Inf
											Arm 6 Left	Inf
											Arm 7 Ahead	Inf
4/1	U		2	3	60.0	Inf	-	-	-	-	-	-
5/1	U		2	3	60.0	Inf	-	-	-	-	-	-
6/1	U		2	3	60.0	Inf	-	-	-	-	-	-
7/1	U		2	3	60.0	Inf	-	-	-	-	-	-

Give-Way Lane Input Data

Junction: A167/The Avenue/Station Lane
There are no Opposed Lanes in this Junction

Traffic Flow Groups

Flow Group	Start Time	End Time	Duration	Formula
3: '2028 Baseline AM'	08:00	09:00	01:00	

Traffic Flows, Actual

Actual Flow :

	Destination					
	A	B	C	D	Tot.	
Origin	A	0	339	170	17	526
	B	236	0	235	24	495
	C	88	155	0	162	405
	D	0	0	0	0	0
	Tot.	324	494	405	203	1426

MTP Results Summary

Network Results

Item	Lane Description	Lane Type	Full Phase	Arrow Phase	Num Greens	Total Green (s)	Arrow Green (s)	Demand Flow (pcu)	Sat Flow (pcu/Hr)	Capacity (pcu)	Deg Sat (%)	Turners In Gaps (pcu)	Turners When Unopposed (pcu)	Turners In Intergreen (pcu)	Total Delay (pcuHr)	Mean Max Queue (pcu)
Network	-	-	-		-	-	-	-	-	-	72.6%	0	0	0	15.1	-
A167/The Avenue/Station Lane	-	-	-		-	-	-	-	-	-	72.6%	0	0	0	15.1	-
1/1	Durham Road Southbound Ahead Left	U	B		1	37	-	356	1885	796	44.7%	-	-	-	2.2	6.7
1/2	Durham Road Southbound Right	U	C		1	10	-	170	1915	234	72.6%	-	-	-	3.1	5.3
2/1+2/2	Durham Road Northbound Left Ahead Right	U	A		1	22	-	495	1975:1945	325+360	72.2 : 72.2%	-	-	-	5.2	7.5
3/1	Station Lane Right Left Ahead	U	D		1	24	-	405	2015	560	72.4%	-	-	-	4.6	10.4
C1						PRC for Signalled Lanes (%):	23.9	Total Delay for Signalled Lanes (pcuHr):			15.12	Cycle Time (s): 90				
						PRC Over All Lanes (%):	23.9	Total Delay Over All Lanes(pcuHr):			15.12					

MTP Results Summary
Network Layout Diagram

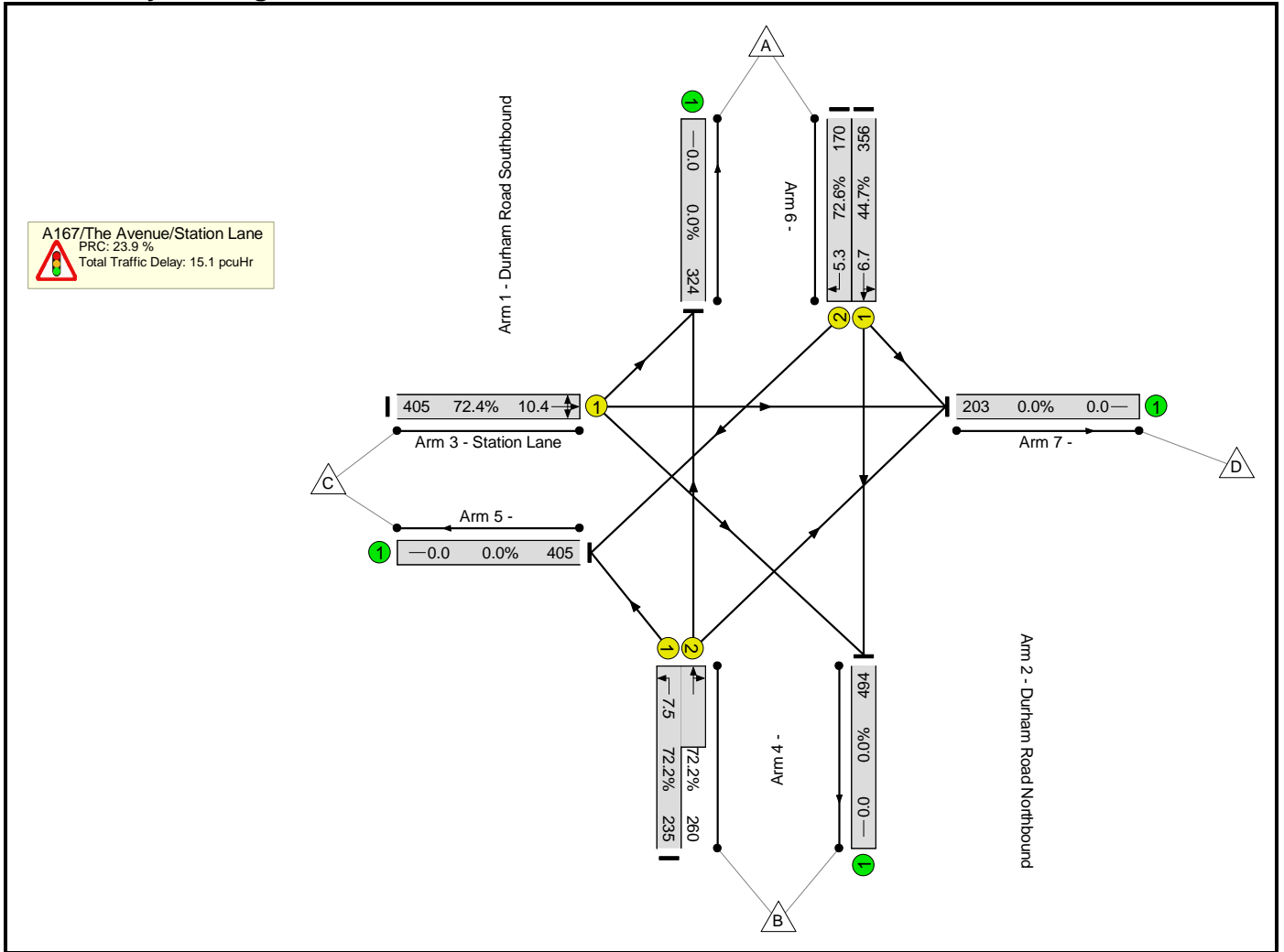

Scenario 4: 'Scenario 4' (FG4: '2028 Baseline PM', Plan 1: 'Network Control Plan 1')

Stage Sequence Diagram

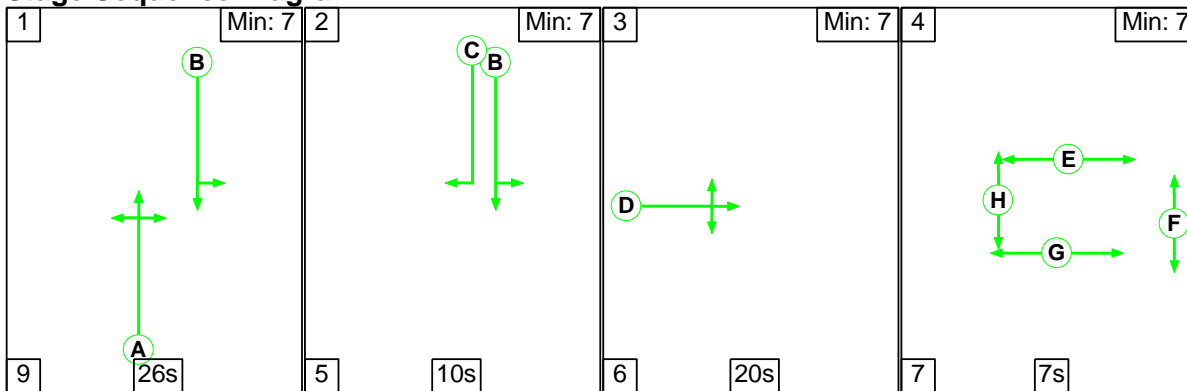

Lane Input Data

Junction: A167/The Avenue/Station Lane												
Lane	Lane Type	Phases	Start Disp.	End Disp.	Physical Length (PCU)	Sat Flow Type	Def User Saturation Flow (PCU/Hr)	Lane Width (m)	Gradient	Nearside Lane	Turns	Turning Radius (m)
1/1 (Durham Road Southbound)	U	B	2	3	60.0	Geom	-	2.70	0.00	Y	Arm 4 Ahead	Inf
											Arm 7 Left	Inf
1/2 (Durham Road Southbound)	U	C	2	3	60.0	Geom	-	3.00	0.00	Y	Arm 5 Right	Inf
2/1 (Durham Road Northbound)	U	A	2	3	60.0	Geom	-	3.60	0.00	Y	Arm 5 Left	Inf
2/2 (Durham Road Northbound)	U	A	2	3	5.0	Geom	-	3.30	0.00	Y	Arm 6 Ahead	Inf
											Arm 7 Right	Inf
3/1 (Station Lane)	U	D	2	3	60.0	Geom	-	4.00	0.00	Y	Arm 4 Right	Inf
											Arm 6 Left	Inf
											Arm 7 Ahead	Inf
4/1	U		2	3	60.0	Inf	-	-	-	-	-	-
5/1	U		2	3	60.0	Inf	-	-	-	-	-	-
6/1	U		2	3	60.0	Inf	-	-	-	-	-	-
7/1	U		2	3	60.0	Inf	-	-	-	-	-	-

Give-Way Lane Input Data

Junction: A167/The Avenue/Station Lane
There are no Opposed Lanes in this Junction

Traffic Flow Groups

Flow Group	Start Time	End Time	Duration	Formula
4: '2028 Baseline PM'	17:00	18:00	01:00	

Traffic Flows, Actual

Actual Flow :

	Destination					
	A	B	C	D	Tot.	
Origin	A	0	494	178	21	693
	B	349	0	149	12	510
	C	110	187	0	67	364
	D	0	0	0	0	0
	Tot.	459	681	327	100	1567

MTP Results Summary

Network Results

Item	Lane Description	Lane Type	Full Phase	Arrow Phase	Num Greens	Total Green (s)	Arrow Green (s)	Demand Flow (pcu)	Sat Flow (pcu/Hr)	Capacity (pcu)	Deg Sat (%)	Turners In Gaps (pcu)	Turners When Unopposed (pcu)	Turners In Intergreen (pcu)	Total Delay (pcuHr)	Mean Max Queue (pcu)	
Network	-	-	-		-	-	-	-	-	-	77.4%	0	0	0	16.9	-	
A167/The Avenue/Station Lane	-	-	-		-	-	-	-	-	-	77.4%	0	0	0	16.9	-	
1/1	Durham Road Southbound Ahead Left	U	B		1	41	-	515	1885	880	58.5%	-	-	-	3.2	10.1	
1/2	Durham Road Southbound Right	U	C		1	10	-	178	1915	234	76.1%	-	-	-	3.4	5.8	
2/1+2/2	Durham Road Northbound Left Ahead Right	U	A		1	26	-	510	1975:1945	197+477	75.7 : 75.7%	-	-	-	5.3	10.7	
3/1	Station Lane Right Left Ahead	U	D		1	20	-	364	2015	470	77.4%	-	-	-	4.9	10.2	
C1						PRC for Signalled Lanes (%):	16.3	Total Delay for Signalled Lanes (pcuHr):			16.89	Cycle Time (s):		90			
						PRC Over All Lanes (%):	16.3	Total Delay Over All Lanes(pcuHr):			16.89						

MTP Results Summary
Network Layout Diagram

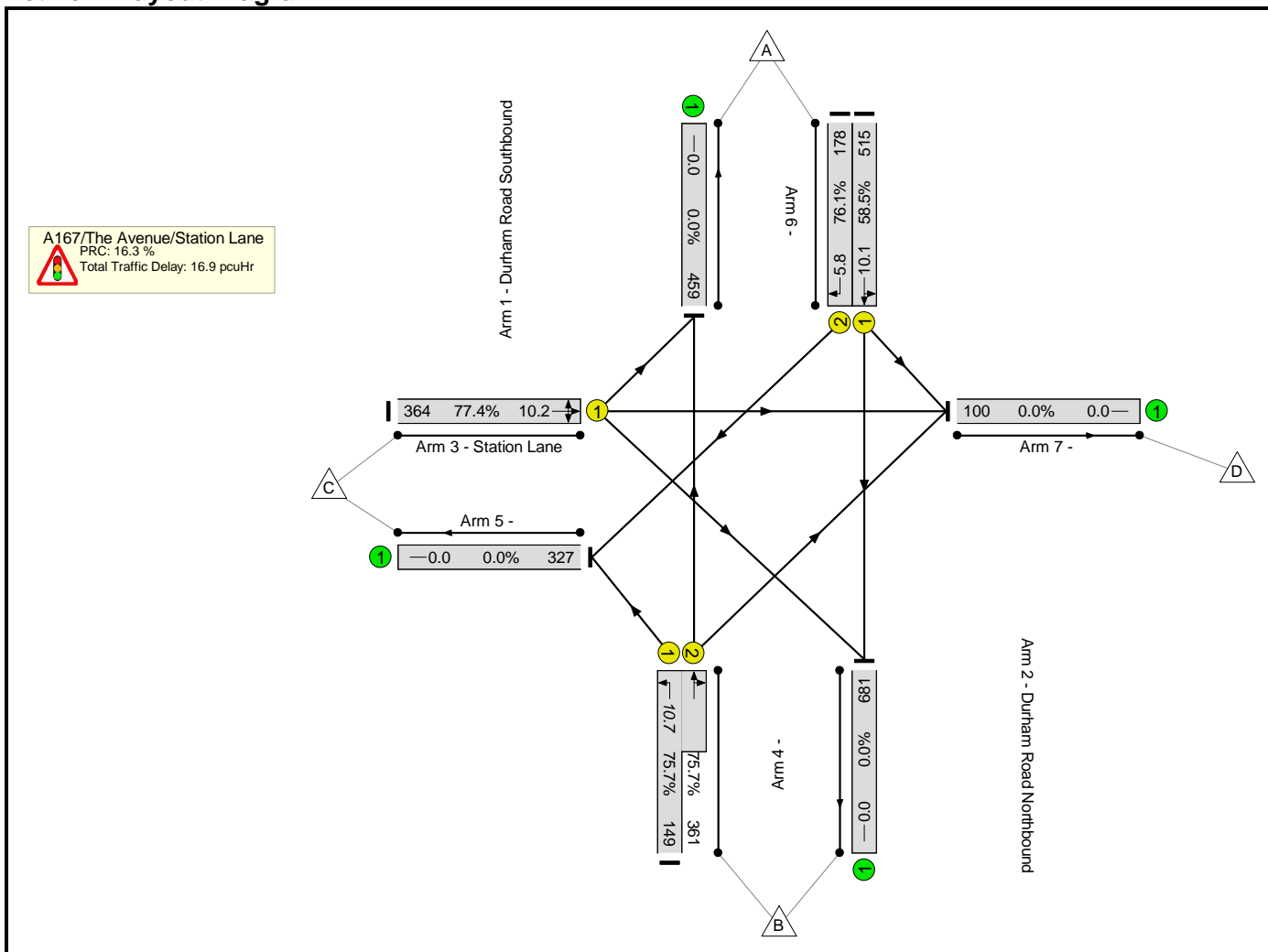

Scenario 5: 'Scenario 5' (FG5: '2028 Baseline + CD + Dev AM', Plan 1: 'Network Control Plan 1')
Stage Sequence Diagram

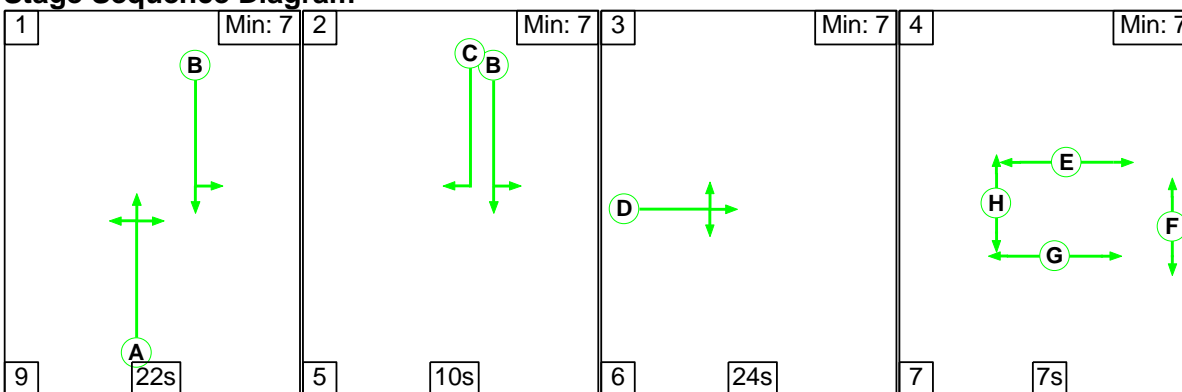

Lane Input Data

Junction: A167/The Avenue/Station Lane												
Lane	Lane Type	Phases	Start Disp.	End Disp.	Physical Length (PCU)	Sat Flow Type	Def User Saturation Flow (PCU/Hr)	Lane Width (m)	Gradient	Nearside Lane	Turns	Turning Radius (m)
1/1 (Durham Road Southbound)	U	B	2	3	60.0	Geom	-	2.70	0.00	Y	Arm 4 Ahead	Inf
											Arm 7 Left	Inf
1/2 (Durham Road Southbound)	U	C	2	3	60.0	Geom	-	3.00	0.00	Y	Arm 5 Right	Inf
2/1 (Durham Road Northbound)	U	A	2	3	60.0	Geom	-	3.60	0.00	Y	Arm 5 Left	Inf
2/2 (Durham Road Northbound)	U	A	2	3	5.0	Geom	-	3.30	0.00	Y	Arm 6 Ahead	Inf
											Arm 7 Right	Inf
3/1 (Station Lane)	U	D	2	3	60.0	Geom	-	4.00	0.00	Y	Arm 4 Right	Inf
											Arm 6 Left	Inf
											Arm 7 Ahead	Inf
4/1	U		2	3	60.0	Inf	-	-	-	-	-	-
5/1	U		2	3	60.0	Inf	-	-	-	-	-	-
6/1	U		2	3	60.0	Inf	-	-	-	-	-	-
7/1	U		2	3	60.0	Inf	-	-	-	-	-	-

Give-Way Lane Input Data

Junction: A167/The Avenue/Station Lane
There are no Opposed Lanes in this Junction

Traffic Flow Groups

Flow Group	Start Time	End Time	Duration	Formula
5: '2028 Baseline + CD + Dev AM'	08:00	09:00	01:00	

Traffic Flows, Actual

Actual Flow :

	Destination					
	A	B	C	D	Tot.	
Origin	A	0	363	175	23	561
	B	247	0	236	24	507
	C	104	158	0	168	430
	D	0	0	0	0	0
	Tot.	351	521	411	215	1498

MTP Results Summary

Network Results

Item	Lane Description	Lane Type	Full Phase	Arrow Phase	Num Greens	Total Green (s)	Arrow Green (s)	Demand Flow (pcu)	Sat Flow (pcu/Hr)	Capacity (pcu)	Deg Sat (%)	Turners In Gaps (pcu)	Turners When Unopposed (pcu)	Turners In Intergreen (pcu)	Total Delay (pcuHr)	Mean Max Queue (pcu)	
Network	-	-	-		-	-	-	-	-	-	76.8%	0	0	0	16.5	-	
A167/The Avenue/Station Lane	-	-	-		-	-	-	-	-	-	76.8%	0	0	0	16.5	-	
1/1	Durham Road Southbound Ahead Left	U	B		1	37	-	386	1885	796	48.5%	-	-	-	2.5	7.4	
1/2	Durham Road Southbound Right	U	C		1	10	-	175	1915	234	74.8%	-	-	-	3.3	5.6	
2/1+2/2	Durham Road Northbound Left Ahead Right	U	A		1	22	-	507	1975:1945	316+363	74.7 : 74.7%	-	-	-	5.5	8.2	
3/1	Station Lane Right Left Ahead	U	D		1	24	-	430	2015	560	76.8%	-	-	-	5.2	11.4	
		C1			PRC for Signalled Lanes (%): 17.2				Total Delay for Signalled Lanes (pcuHr): 16.46				Cycle Time (s): 90				
				PRC Over All Lanes (%): 17.2				Total Delay Over All Lanes(pcuHr): 16.46									

MTP Results Summary
Network Layout Diagram

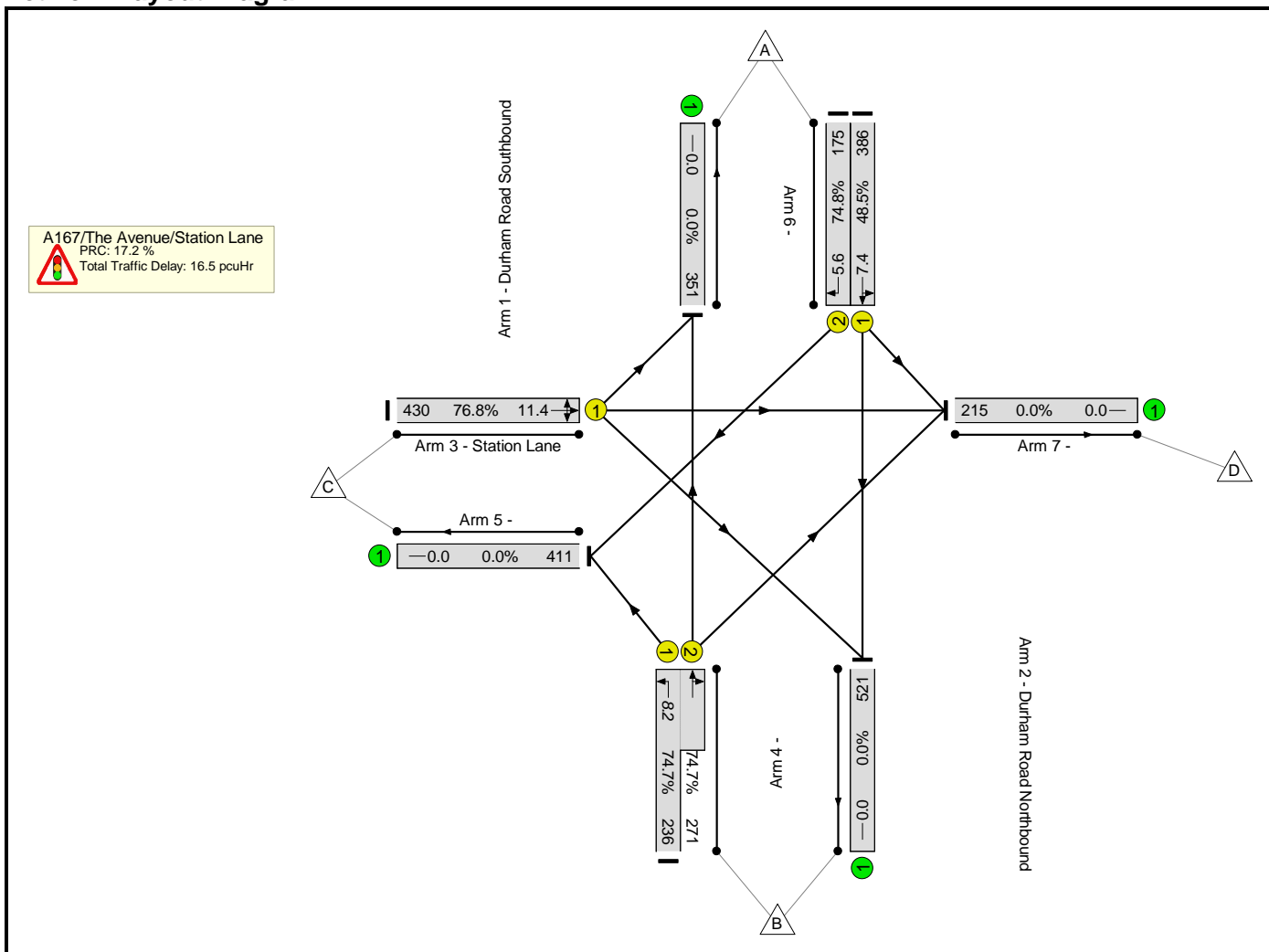

Scenario 6: 'Scenario 6' (FG6: '2028 Baseline + CD + Dev PM', Plan 1: 'Network Control Plan 1')

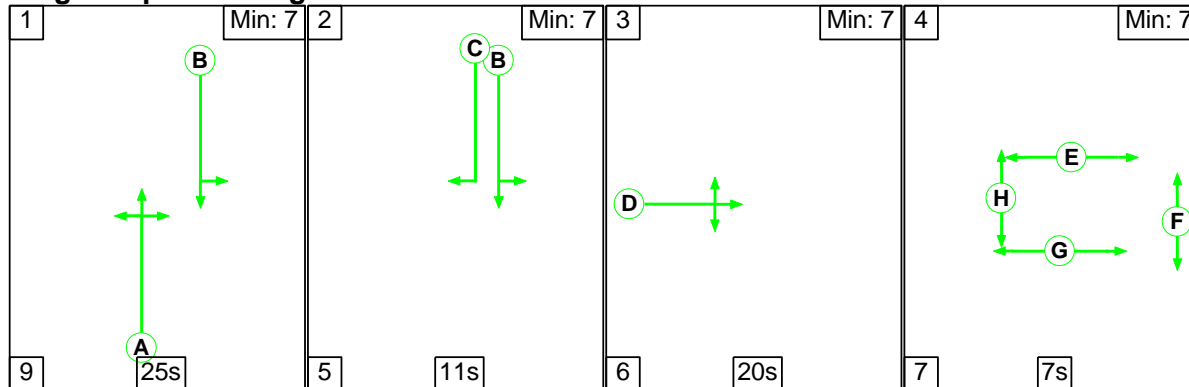

Lane Input Data

Junction: A167/The Avenue/Station Lane												
Lane	Lane Type	Phases	Start Disp.	End Disp.	Physical Length (PCU)	Sat Flow Type	Def User Saturation Flow (PCU/Hr)	Lane Width (m)	Gradient	Nearside Lane	Turns	Turning Radius (m)
1/1 (Durham Road Southbound)	U	B	2	3	60.0	Geom	-	2.70	0.00	Y	Arm 4 Ahead	Inf
											Arm 7 Left	Inf
1/2 (Durham Road Southbound)	U	C	2	3	60.0	Geom	-	3.00	0.00	Y	Arm 5 Right	Inf
2/1 (Durham Road Northbound)	U	A	2	3	60.0	Geom	-	3.60	0.00	Y	Arm 5 Left	Inf
2/2 (Durham Road Northbound)	U	A	2	3	5.0	Geom	-	3.30	0.00	Y	Arm 6 Ahead	Inf
											Arm 7 Right	Inf
3/1 (Station Lane)	U	D	2	3	60.0	Geom	-	4.00	0.00	Y	Arm 4 Right	Inf
											Arm 6 Left	Inf
											Arm 7 Ahead	Inf
4/1	U		2	3	60.0	Inf	-	-	-	-	-	-
5/1	U		2	3	60.0	Inf	-	-	-	-	-	-
6/1	U		2	3	60.0	Inf	-	-	-	-	-	-
7/1	U		2	3	60.0	Inf	-	-	-	-	-	-

Give-Way Lane Input Data

Junction: A167/The Avenue/Station Lane
There are no Opposed Lanes in this Junction

Traffic Flow Groups

Flow Group	Start Time	End Time	Duration	Formula
6: '2028 Baseline + CD + Dev PM'	17:00	18:00	01:00	

Traffic Flows, Actual

Actual Flow :

	Destination					
	A	B	C	D	Tot.	
Origin	A	0	503	193	24	720
	B	367	0	152	12	531
	C	117	188	0	70	375
	D	0	0	0	0	0
	Tot.	484	691	345	106	1626

MTP Results Summary

Network Results

Item	Lane Description	Lane Type	Full Phase	Arrow Phase	Num Greens	Total Green (s)	Arrow Green (s)	Demand Flow (pcu)	Sat Flow (pcu/Hr)	Capacity (pcu)	Deg Sat (%)	Turners In Gaps (pcu)	Turners When Unopposed (pcu)	Turners In Intergreen (pcu)	Total Delay (pcuHr)	Mean Max Queue (pcu)
Network	-	-	-		-	-	-	-	-	-	81.8%	0	0	0	18.5	-
A167/The Avenue/Station Lane	-	-	-		-	-	-	-	-	-	81.8%	0	0	0	18.5	-
1/1	Durham Road Southbound Ahead Left	U	B		1	41	-	527	1885	880	59.9%	-	-	-	3.3	10.4
1/2	Durham Road Southbound Right	U	C		1	11	-	193	1915	255	75.6%	-	-	-	3.5	6.1
2/1+2/2	Durham Road Northbound Left Ahead Right	U	A		1	25	-	531	1975:1945	186+463	81.8 : 81.8%	-	-	-	6.3	12.3
3/1	Station Lane Right Left Ahead	U	D		1	20	-	375	2015	470	79.8%	-	-	-	5.3	10.6
		C1			PRC for Signalled Lanes (%): 10.0		PRC Over All Lanes (%): 10.0		Total Delay for Signalled Lanes (pcuHr): 18.45		Total Delay Over All Lanes(pcuHr): 18.45		Cycle Time (s): 90			

MTP Results Summary
Network Layout Diagram

A167/The Avenue/Station Lane
 PRC: 10.0 %
 Total Traffic Delay: 18.5 pcuHr

